



February 29, 2024

Chris Wanamaker, County Engineer  
Brent Billingsley, Community Development Director  
85 N. Florence Street  
P.O. Box 749  
Florence, AZ 85132

Re: Black Butte – Request for Waiver/Modification from Chapter 10, § 10.2.2 of the Pinal County Subdivision & Infrastructure Design Manual

Dear Chris Wanamaker and Brent Billingsley,

On behalf of Black Butte 80, LLC we are requesting a waiver/modification from Chapter 10, § 10.2.2 of the Pinal County Subdivision & Infrastructure Design Manual for the Black Butte development, regarding the requirement for a sewer collection and treatment system for subdivisions with lots less than one acre in area.

Given the unavailability of a community sewer system for Black Butte, located at the northeast corner of Weaver Road and McCartney Road, our proposal seeks approval for the use of alternative on-site sewer treatment technologies. This approach is in line with §§ 10.2.3, 10.2.4, and 10.2.5 of the Manual, and are seeking approvals from the Pinal County Environmental Health Department and the Arizona Department of Environmental Quality accordingly.

Our request is grounded in PCDSC § 3.60.020, especially section 3.60.030, which permits modifications and waivers under exceptional circumstances. Black Butte's unique situation, detailed further below, exemplifies such circumstances, warranting a deviation from the standard sewer system requirements. Our alternative sewer treatment proposal aims to ensure environmental safety and sustainability while aligning with the county's comprehensive plan.

Black Butte comprises approximately 78 acres and is a joint venture by Petersen Properties & Management and Absolute Homes, aimed at contributing significantly to the housing inventory in the area. The development is designed to include approximately 120 lots of 20,000 square feet each, echoing the essence of the previously approved "The Ridge at Black Butte" plan from 1997. This plan aligns with our successful implementation of alternative sewer systems in Chaparral Estates, reinforcing our request's validity for similar considerations at Black Butte. The proximity of both developments are shown in the map below:

**McCartney & Weaver | Pinal County, AZ**

The Hogan Group  
 7114 E Stetson Drive  
 Suite 400  
 Scottsdale, AZ 85251  
 (602) 553-4117

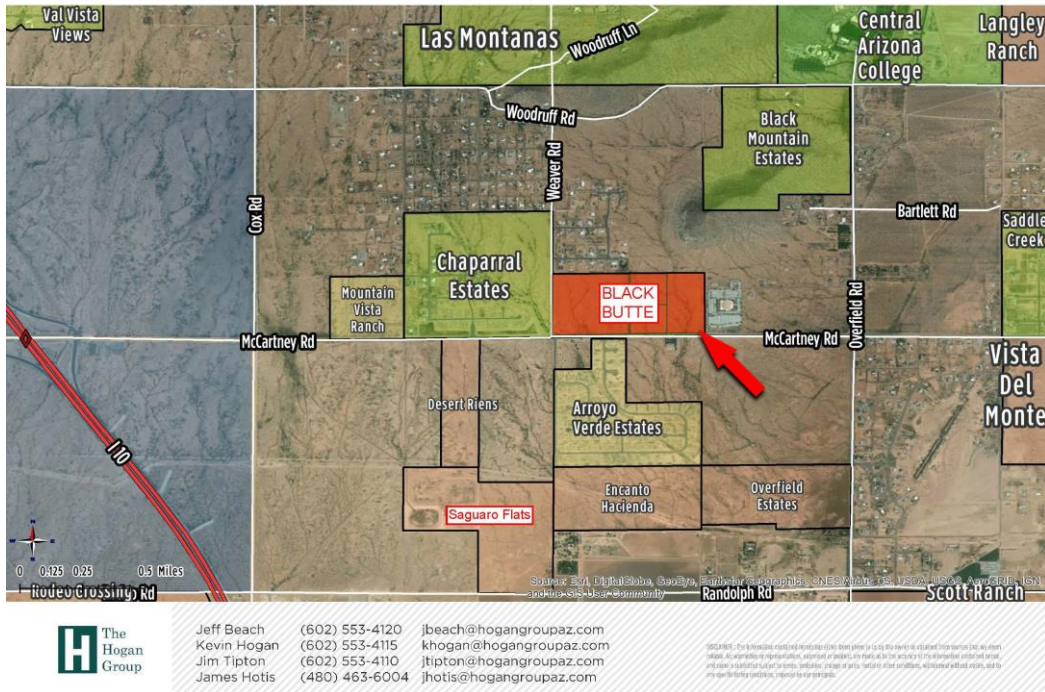

Jeff Beach (602) 553-4120 jbeach@hogangroupaz.com  
 Kevin Hogan (602) 553-4115 khogan@hogangroupaz.com  
 Jim Tipton (602) 553-4110 jtipton@hogangroupaz.com  
 James Hotis (480) 463-6004 jhotis@hogangroupaz.com

DISCLAIMER: This information is provided for informational purposes only and does not constitute an offer of any securities. The information is not intended to be used as a basis for investment decisions. The information is not intended to be used as a basis for investment decisions. The information is not intended to be used as a basis for investment decisions.

Moreover, the project has received a Certificate of Assured Water Supply for 122 lots. However, the absence of planned sewer main extensions to this area necessitates our pursuit of alternative sewer systems to fully utilize the water allocation, thereby preventing a significant reduction in buildable lots and loss of valuable housing resources.

In anticipation of updating "The Ridge at Black Butte" to meet current standards, potentially reducing the lot count from the previously approved 122, we have engaged with County Staff. Their direction has charted a path towards a possible solution, emphasizing the alternative sewer system's acceptance in the platting process, subject to the Pinal County Board's approval.

We intend to update the originally approved design for "The Ridge at Black Butte" to meet current Pinal County design standards. This may require elimination of a few lots from the previously approved total of 122.

We have been actively coordinating with County Staff, who have given direction with the following:

1. Prior to spending significant time and money to process a new updated Preliminary Plat and subsequent Final Plat, Staff and the Developer shall seek approval to update the existing Preliminary Plat, knowing that the alternative sewer system (septic) will be accepted as part of the platting process.
2. Upon approval, the Developer will re-process an amended Preliminary Plat that was previously approved.



Furthermore, to ensure full transparency and responsibility, all homebuyers will be required to sign off on the use of alternative septic systems before closing on their homes. Homebuilder(s) will provide comprehensive information regarding the responsibilities and maintenance of these new systems to all buyers. This step will ensure that homeowners are well informed about their system's functioning and upkeep.

Enclosed, please find detailed plans and supporting documents for our proposed alternative sewer treatment system, illustrating our commitment to a sustainable development model that respects environmental and community welfare.

Thank you for considering our waiver/modification request. We are eager to discuss any aspects of this proposal further and provide any additional information needed.

Sincerely,

Petersen Properties & Management, Inc.

Kevin D. Petersen  
President/Broker

KDP/cvl



MEMORANDUM

---

Date: November 1, 2023 (Revised February 26, 2024)

To: Pinal County

RE: Septic System Utilization Request  
Black Butte  
CVL: #01-04087-01

From: Douglas W. Chubin, P.E.  
Senior Project Manager

---



On behalf of KPHV, LLC as the developer of the Black Butte project, Coe and Van Loo Consultants, Inc. (CVL) is requesting allowance for use of individual per lot septic systems for disposal of site generated sanitary waste. The Black Butte site contains approximately 78 acres located in Section 32, Township 5 South, Range 7 East of the Gila and Salt River Meridian, Pinal County (County), Arizona. The project includes an assembly of five parcels identified by Pinal County Assessor Parcel Numbers 50975005H, 50975005C, 50975005B, 50975005P, and 50975005M. Black Butte is located at the northeast corner of the intersection of Weaver Road and McCartney Road, west of the City of Casa Grande in unincorporated Pinal County, Arizona.

It is the understanding of CVL that the development was previously approved by Pinal County under the "Preliminary Plat of The Ridge at Black Butte" dated April 28, 1997 by Weckerly & Associates under their job number 960814. The preliminary plat indicated a total of 122 lots with typical lot size of 20,000 square feet. The preliminary plat was also utilized as an exhibit for substantiation and approval of the ADWR Certificate of Assured Water Supply File Number 27-300342 dated October 16, 1997.

Though it is typical for septic systems in Pinal County to be utilized in for minimum one-acre lots it should be noted that the area requirement typically also includes adequate space for water wells since septic use is more common for lots in combination with wells. For the Black Butte project, community water will be provided with a public water main system per the standards of the Arizona Water Company. As such, the area requirements for the support of septic do not require additional spacing to avoid well placement conflicts. This results in a reduced required area and can support the request for 20,000 square feet average lot sizes as per the preliminary

plat. Further, use of individual lot septic systems allows for the full 122 lots as per the approved CAWS and utilization of the extent of the non-transferrable assured water right that would otherwise be unavailable for development.

In regards to water quality of the septic system effluent, it has been noted that the Black Butte project is within a designated Nitrogen Management Area and per ADEQ standards a reduction in Nitrogen is necessary for attainment of groundwater quality. The standard for typical residential wastewater has 53 mg/L of Nitrogen, which in a standard 600 gallon per day household would result in approximately 120 grams per day per acre of Nitrogen. Per the ADEQ Nitrogen reduction requirements, only 39.9 grams per day per acre of Nitrogen would be allowed, which computes to approximately 18 mg/L for the same 600 gallon per day household. Therefore, any septic system being proposed would require additional treatment beyond a standard digester tank and leach field. The necessary nitrogen reduction can be accomplished with the addition of an aerobic system to add Oxygen into the wastewater to create a reaction to release excess Nitrogen into the atmosphere. Detailed Nitrogen Loading Calculations to support Black Butte Alternative Sewer Design have been provided as a part of this Memorandum.

ADEQ has several pre-approved proprietary products that can be utilized to achieve the necessary Nitrogen reduction. For Black Butte, it is proposed to utilize a product similar to Singulair TNT-500 as manufactured by Norweco, Inc. The ADEQ approval for the Singulair TNT product is included with this memorandum request and has been documented to reduce the total Nitrogen in the effluent to 15 mg/L. The TNT-500 designation is for the design flow capacity of 500/600 gallons per day for a household to meet the County flow requirement for a typical home.

Included with the ADEQ pre-approval, this memorandum also provides the Singulair TNT “Specifications” and the Norweco sales flyer which provide sketches of how the aeration system operates and information on system installation, operation for recirculation of effluent, aeration, solid sedimentation, and Nitrogen release.

#### DESCRIPTION OF REQUEST:

1. **CITATION:** This request is for the allowance of on-lot septic systems for the Black Butte residential subdivision. The septic systems will be installed as per the requirements of Arizona Administrative Code Title 18 “Environmental Quality”, Chapter 9 “Department of Environmental Quality – Water Pollution Control”, Section A309 “General Provisions for On-site Wastewater Treatment Facilities” (AAC R18-9-A309) which by reference include the provisions for Nitrogen reduction per AAC R18-9-A317.
2. **REASON:** The request is needed to allow the previously approved preliminary plat for Black Butte to be engineered for final improvement approvals and constructed. There are no

sanitary sewer facilities near to Black Butte, it would be economically infeasible to construct a lift station and force main to existing sewer. Individual septic systems would be owned and operated by each homeowner.

3. **IMPACTS:** The septic systems will be constructed per ADEQ and County requirements and can be installed to reduce Nitrogen as per the needs of the Nitrogen Management Area. The adverse impact to the groundwater aquifer would be minimal and impacts to the general populace of the County would be negligible.
4. **ALTERNATIVES:** The alternative to granting the request would be to require installation of a lift station and forcemain to be owned and operated by Arizona Water Company or another entity that has the expertise, equipment, and manpower to properly operate and maintain the sewer system. This will result in additional costs to all parties and highly detrimental delays to development of Black Butte.

## Black Butte - Alternative Sewer Design Nitrogen Loading Calculations

**Project Information**

Site Area = 78.74 AC  
# of Lots = 122 DU

ADEQ R18-9-E323 (4.23 General Permit: 3000 to less than 24,000 Gallons per Day Design Flow)  
Per Section A.4.a.i the designer is to assume 39.9 grams of total Nitrogen per day per acre of the development allowed.  
Total Nitrogen = 78.74 AC x 39.9 g/day/AC = 3141.73 g/day ALLOWABLE

**ADEQ R18-5-404 (Size of Lots)**

Lot shall be sufficient to accommodate disposal for a four bedroom house, which utilizes a 600 gallon tank.

Standard untreated sewage contains 53 mg/L of Nitrogen so a four bedroom house would generate loading as follows.

Nitrogen per acre =  $53 \text{ mg/L} / 1000 \text{ mg/g} \times 3.78 \text{ L/gallon} \times 600 \text{ gallon} = 120.20 \text{ g/day}$   
Nitrogen generated =  $78.74 \text{ AC} \times 120.20 \text{ g/day/AC} = 9464.86 \text{ g/day}$  GENERATED (without treatment)

**Required Nitrogen Reduction (Generated minus Allowable)**

Nitrogen Reduction =  $9464.86 \text{ g/day} - 3141.73 \text{ g/day} = 6323.14 \text{ g/day}$  Therefore, **Reduction Required**

**Proposed Nitrogen Reduction System: Norweco Singulair TNT-500**

Nitrogen per acre =  $15 \text{ mg/L} / 1000 \text{ mg/g} \times 3.78 \text{ L/gallon} \times 600 \text{ gallon} = 34.02 \text{ g/day}$  Performance: 15 mg/L  
Treated Loading =  $78.74 \text{ AC} \times 34.02 \text{ g/day/AC} = 2678.73 \text{ g/day}$  LOADING (with treatment)

**Total Treated Loading compared to Allowable discharge:**

$2678.73 \text{ g/day} < 3141.73 \text{ g/day}$  CHECK  
 $34.02 \text{ g/day/AC} < 39.9 \text{ g/day/AC}$  CHECK

The selected system will discharge less total Nitrogen than allowed by ADEQ standard.

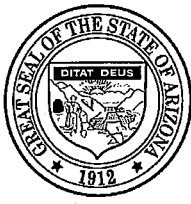

Douglas A. Ducey  
Governor

# ARIZONA DEPARTMENT OF ENVIRONMENTAL QUALITY



Henry R. Darwin  
Director

## Notice of Proprietary Treatment Product Listing Pursuant to Arizona Administrative Code R18-9-A309(E) ADEQ File No. 20070728

### 1. Proprietary Treatment Product Name, Model, and Description

Product Name: TNT Wastewater Treatment System  
 Model: TNT-500, TNT-750, TNT-1000, TNT-1250, and TNT-1500.  
 Description: The TNT is a treatment process with three zones: 1) primary clarifier, 2) suspended growth aeration, and 3) BIO-KINETIC® final clarification. The final chamber is where an optional disinfection device may be installed.

### 2. Manufacturer Information

Name: Norweco, Inc.  
 Address: 220 Republic Street  
 City/State/Zip: Norwalk, OH 44857  
 Phone: 419-668-4471  
 Fax: 419-663-5440  
 Website: [www.norweco.com](http://www.norweco.com)

### 3. Recognized Treatment Performance

Parameter	Averaging Time	Maximum Value for Parameter & Averaging Time
5-Day Biochemical Oxygen Demand (BOD <sub>5</sub> ), mg/l	30-day arithmetic mean	10
Total Suspended Solids (TSS), mg/l	30-day arithmetic mean	10
Total nitrogen (as nitrogen), mg/l	five-month arithmetic mean	15
Total coliform, colony forming units/100ml	95th percentile	300,000

**4. Product Applicability and Limitations for Use for a Recognized General Permit Technology**

<b>Applicability:</b> This listing is for the treatment technology specified in A.A.C. R18-9-E315.
<b>Limitations:</b>
<p>A. This product is only approved for design flow per A.A.C. R18-9-A309 (B)(3) from 500 to 1,500 gpd from residential sources only.</p> <p>B. This listing is only for technology approved in accordance with A.A.C. R18-9-E315 and does not include any other technology/products including disinfection devices.</p> <p>C. This listing EXCLUDES appurtenances which are considered to be “other manufactured materials and components” such as an alarm, control panel, control, switch, timer, wiring, other electrical devices, and installation components; which are subject to both the manufacturer specifications and any more restrictive requirement in 18 A.A.C. 9, Article 3..</p>

**5. Alternative Criteria and Exceptions for Use Under the Recognized General Permit Technology**

<b>Alternative Criteria:</b>	None
<b>Exceptions:</b>	R18-9-E315(B&C)- Proposed total nitrogen reduction equal to but not less than 28 mg/l.

**6. Documents Used as the Basis for this Proprietary Treatment Product Listing Notice**

Application for Treatment Product Listing:	09/27/07
Third party test data:	NSF Final Report Singulair Model TNT-500, dated June 2006. Analysis of Fecal Coliform Reduction, Singulair Model TNT-500 with UV Disinfection, dated May 2006, NSF 245 Final report Singulair Model TNT-500, dated November 2007.
Parts List:	Singulair Model TNT Total Nitrogen Treatment Technical Manual.
Installation Instructions:	Installation Specifications, dated November 2010 and Installation Specification Book, dated November 2010
Manufacturer’s Warrantee:	Owner’s Manual (Page # 11), November 2010.
Manufacturer’s Specifications:	Installation Specification Book, dated November 2010
Owner’s Manual	Owner’s Manual, Total 11 pages, Revised November 2010

**7. Terms and Conditions for this Proprietary Treatment Product Listing Notice**

- A. This Notice of Proprietary Treatment Product Listing shall remain in effect until any of the following occurs:
  - i. Applicable provisions of the Arizona Administrative Code, Title 18, Chapter 9, Article 3 are revised;
  - ii. Documents used for the basis of this listing are altered or modified;
  - iii. Manufacturer claims which are relied upon for this listing are later determined to contain an error or omission;
  - iv. The manufacturer requests termination of this listing;
  - v. A listing error or omission is identified; or
  - vi. The manufacturer and ADEQ mutually agree to reissue this notification to incorporate correction or update for any reason.
- B. This Notice of Proprietary Treatment Product Listing does not apply when the:
  - i. Listed proprietary treatment product is modified or operated in a manner that conflicts with Arizona law or the documents used for the basis of this listing action in Section 6.
  - ii. Listed proprietary treatment products is used in a manner that cannot be achieved the performance in Section 3 above.
- C. This Notice of Proprietary Treatment Product Listing applies solely to the product specified in Section 1 above.
- D. The manufacturer is responsible for notifying the ADEQ of changes to contact information at the following address:
 

Attention: Product Listing Supervisor  
 Engineering Review Desk,  
 1110 West Washington Street  
 Phoenix, AZ 85007.
- E. The listing by ADEQ of any proprietary product or service is not an endorsement by ADEQ or the State of Arizona. ADEQ does not endorse, represent, guarantee, warranty or defend the use of any product which is authorized for use pursuant to A.A.C. R18-9-A309(E). Product providers are a direct source unrelated to ADEQ or the State of Arizona. Use of any listed product is at the user's risk and the State assumes no liability.

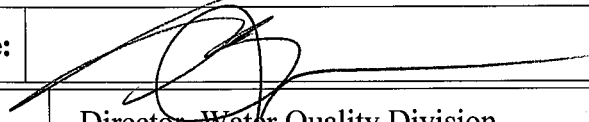
<b>Signature:</b>		<b>Date Signed:</b>	5-22-15
<b>Title:</b>	Director, Water Quality Division		

ADEQ File #:20070728  
 RDR

# SINGULAIR® TNT® THE PRECAST CONCRETE ADVANCED TREATMENT UNIT

**NITROGEN REDUCING WASTEWATER TREATMENT SYSTEM  
ACCOMPLISHES NITRIFICATION AND DENITRIFICATION  
GREATER THAN 68% REDUCTION IN TOTAL NITROGEN**

If regulations in your area are demanding nutrient reduction for onsite treatment and disposal systems, install a Singulair Model TNT! Total Nitrogen Treatment you can rely on from the leader in advanced treatment unit technology.

**NSF STANDARD 245 CERTIFIED PERFORMANCE  
AFFORDABLE DOMESTIC WASTEWATER TREATMENT  
COMPLIES WITH THE MOST STRINGENT EFFLUENT CRITERIA**

The Singulair Model TNT system biologically oxidizes nitrogen compounds without requiring complicated and expensive equipment. Designed to be easily operated and maintained, the TNT system does not require the addition of chemicals or the recirculation of effluent. The Singulair TNT blows away the competition!

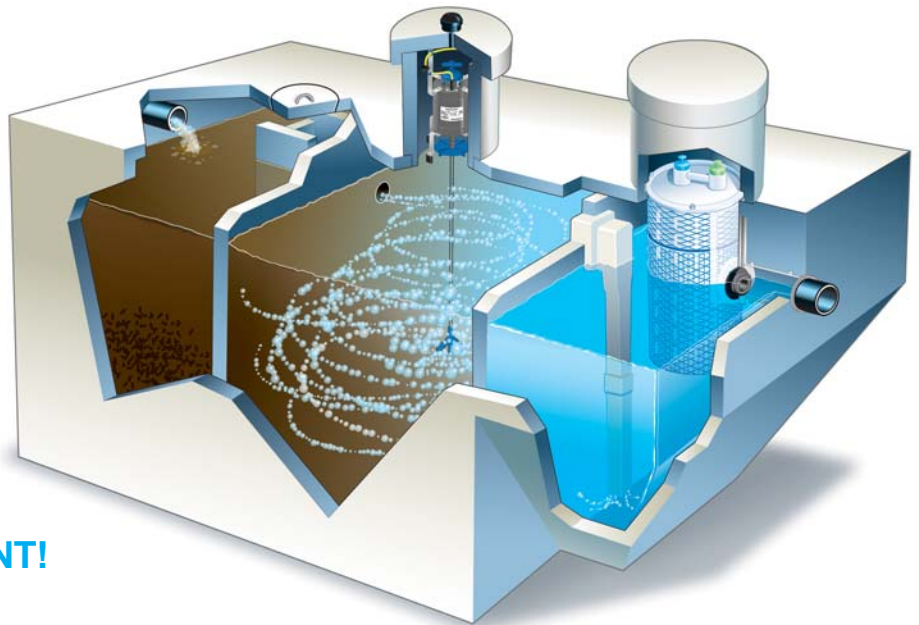

**PERFORMANCE THAT  
PROTECTS THE ENVIRONMENT!**

**7 mg/L NITRATE**

**12 mg/L TOTAL NITROGEN**

**4 mg/L CBOD<sub>5</sub>**

**9 mg/L TSS**



## SINGULAIR® TNT FEATURES

- Precast concrete tank
- Lowest electrical usage
- Surge flows equalized
- No chemicals to add
- Lifetime warranty and exchange
- Sold and serviced by local distributors
- Made in the U.S.A.

***norweco***®

*Engineering the future of water  
and wastewater treatment*

220 REPUBLIC STREET  
NORWALK, OHIO, USA 44857-1156  
TELEPHONE (419) 668-4471  
FAX (419) 663-5440  
[www.norweco.com](http://www.norweco.com)

***norweco***<sup>®</sup>

**SINGULAIR<sup>®</sup> BIO-KINETIC<sup>®</sup>**  
**WASTEWATER TREATMENT SYSTEM**  
**MODEL TNT<sup>®</sup>**

**GENERAL SPECIFICATIONS**

The contractor shall furnish and install one complete Singulair Bio-Kinetic Model TNT system for Total Nitrogen Treatment with all necessary parts and equipment as described in the following specifications. Treatment of the domestic wastewater shall be accomplished by the extended aeration process with non-mechanical flow equalization, pretreatment of the influent and filtration of the final effluent. In addition to primary, secondary and tertiary treatment of the wastewater flow, the treatment system shall provide nitrification, denitrification, and if required, chlorination and dechlorination of the effluent prior to discharge. All treatment processes shall be contained within reinforced precast concrete tankage meeting the requirements of ACI Standard 318. The wastewater treatment system shall be a Singulair Model TNT as manufactured by Norweco, Inc., Norwalk, Ohio, USA. Systems utilizing fiberglass, steel, or plastic tankage are subject to flotation when dewatered and shall not be considered for this application.

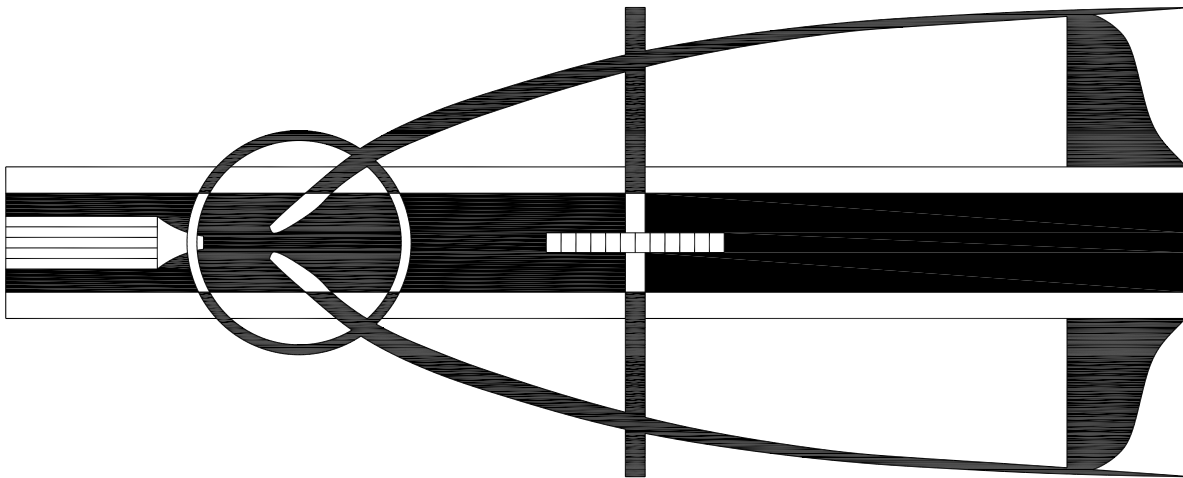

The wastewater treatment system shall be capable of reducing Total Nitrogen without the addition of chemicals, specialized add-on processes or additional components. Nitrification and denitrification shall be accomplished within the chambers of the treatment system prior to effluent disposal. Biological reduction of nitrogen shall occur naturally by autotrophic bacteria, capable of converting ammonium nitrogen to nitrate and heterotrophic bacteria, capable of transforming nitrate to harmless gas. The treatment system shall include precast concrete tankage providing separate pretreatment, aeration and clarification chambers. Principal items of electro-mechanical equipment shall be a 1725 RPM mechanical aerator, UL listed Service Pro control center with MCD technology, Bio-Static sludge return and Bio-Kinetic tertiary treatment device for flow equalization and final filtration of system effluent.

**SPECIFICATIONS**

# SINGULAIR®

## OPERATING CONDITIONS

Total holding capacity of the system shall provide a minimum of 48 hour retention of the daily flow. The pretreatment chamber shall provide at least 18 hour retention, the extended aeration chamber shall provide at least 24 hour retention and the clarification chamber shall provide at least 6 hour retention. The non-mechanical flow equalization device shall increase each individual chamber and total system retention time in direct proportion to loading. Design of the system shall include a compartmented tank and non-mechanical flow equalization device to insure successful treatment performance without upset even when the significant runoff period is six hours. Hydraulic design considerations of the system and flow equalization device shall be such that intermittent peak flow factors as high as four shall not upset hydraulic reliability within the system. System performance in compliance with the requirements of NSF Standard 245 shall be recognized by an ANSI accredited third-party laboratory and be approved for use by the local governing regulatory agency.

## PRETREATMENT CHAMBER

The pretreatment chamber shall be an integral part of the wastewater treatment system. All domestic wastewater shall be preconditioned and flow equalized while passing through the pretreatment chamber prior to being introduced to the extended aeration chamber. The outlet of the pretreatment chamber shall be equipped with a discharge tee that extends vertically into the liquid so that only the preconditioned equalized flow from the center area of the chamber is displaced to the extended aeration chamber. The discharge tee and transfer port shall be of adequate size to handle a peak flow factor of four without restricting the outlet and disturbing hydraulic displacement to the extended aeration chamber. A removable inspection cover shall be cast into the top of the pretreatment chamber to allow tank and transfer tee inspection. As a safety measure, the uncovered opening shall be small enough to insure that the tank cannot be entered for inspection or service.

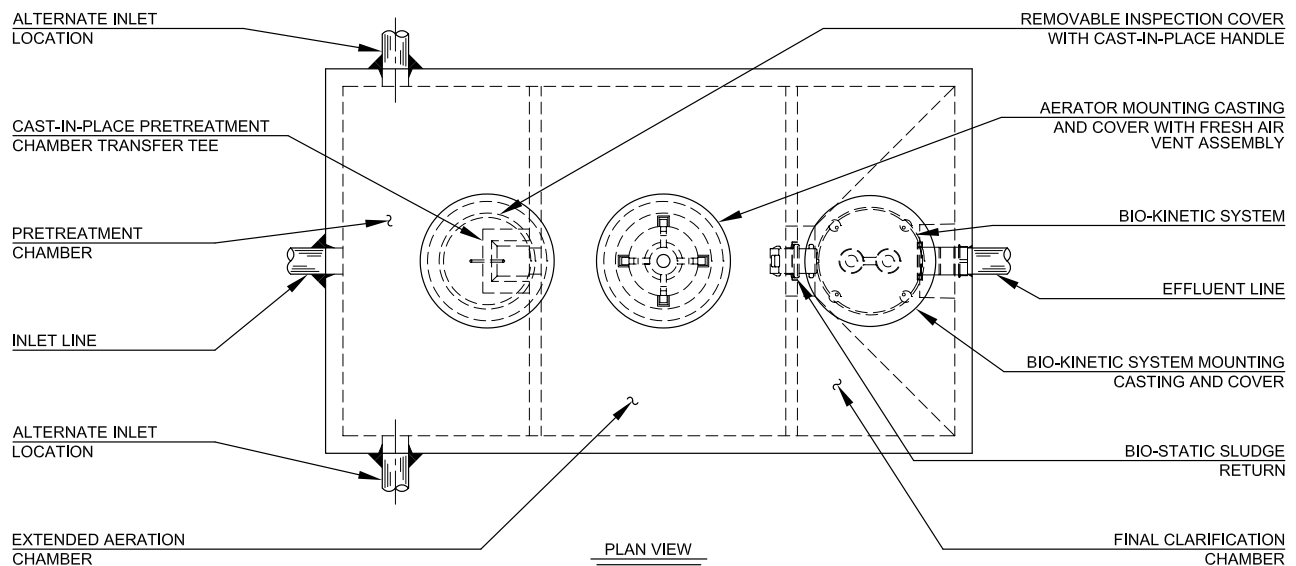

## AERATION CHAMBER

The extended aeration chamber shall provide in excess of 24 hour retention of the equalized daily flow. The chamber shall be of sufficient size to provide a minimum of 80 cubic feet of tank capacity per pound of applied BOD. The aeration chamber length-width-depth ratio shall be designed to insure uniform tank mixing and provide optimum treatment. The aeration chamber(s) shall be an integral part of the system flow path and constructed of properly reinforced 5,000 PSI, 28 day compression strength precast concrete. All castings used to construct the precast concrete tankage shall be monolithic units with external and internal walls incorporated into each section.

# FINAL CLARIFICATION CHAMBER

The final clarification chamber shall consist of 5 functionally independent zones operating together to provide satisfactory settling and clarification of the equalized flow. An inlet zone shall be provided and shall dissipate transfer turbulence at the flow inlet of the clarification chamber. Its performance shall also eliminate turbulence in other zones of the clarifier. Liquid shall be hydraulically displaced from the inlet zone to the sludge return zone. Hydraulic currents shall sweep settled sludge from the hopped walls and return these solids via the inlet zone to the aeration chamber. As solids are removed, liquid is displaced to the hopper zone of the clarifier. In this zone, settling by gravity takes place. Three of the four sidewalls are slanted to form a hopper which directs all settled material back to the sludge return zone. Clarified liquid from the hopper zone shall be displaced into the final settling zone to provide additional clarification of the liquid. The liquid is finally displaced to the outlet zone for final filtration and discharge from the system. Non-mechanical equalization of the flow, through all 5 independent zones, shall provide optimal settling and clarification.

## BIO-STATIC® SLUDGE RETURN

A Bio-Static sludge return shall be installed into the cast-in-place opening(s) in the aeration/clarification chamber wall to provide positive return of settled solids. Aeration chamber hydraulic currents shall enter the sludge return(s) and be directed into the sludge return zone of the clarification chamber. The Bio-Static sludge return shall accomplish resuspension and return of settled solids without disturbing the clarified liquid in the final settling zone and outlet zone.

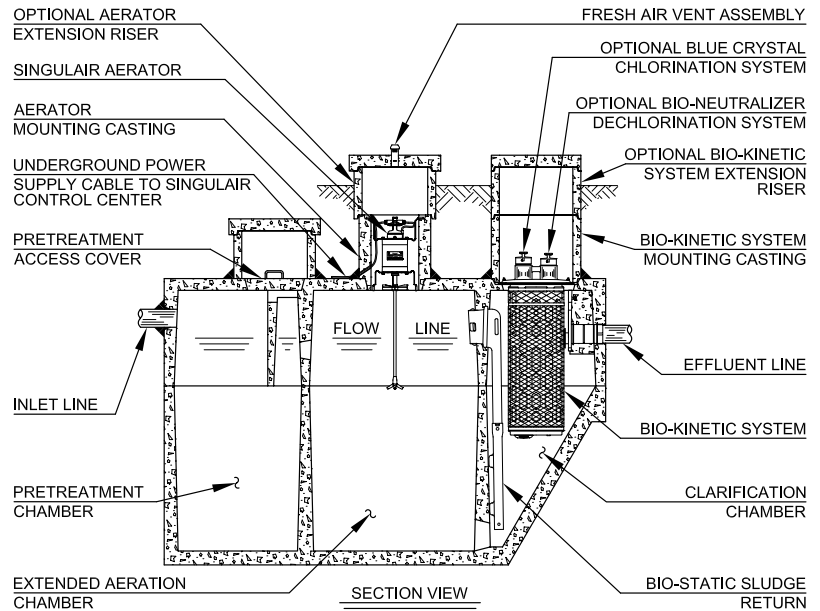

## MECHANICAL AERATOR

Each Singulair aerator shall be installed in a concrete aerator mounting casting above the aeration chamber. Fresh air shall be supplied through a molded plastic vent assembly cast into the concrete access cover above the aerator. The Singulair aerator shall include plated mounting brackets, NEMA 6 rated electrical connector, UL recognized fractional horsepower motor, molded plastic lifting handle, molded plastic air intake screens, molded plastic foam restrictor, stainless steel aspirator shaft and molded glass-filled nylon aspirator tip. The motor shall contain precision manufactured o-ring type seals installed between the motor shell and the machined aluminum endbells to insure watertight integrity is maintained. Molded Viton elastomer shaft seals shall be utilized to protect the bearings from contamination. Only the stainless steel aspirator shaft and glass-filled nylon aspirator tip shall be installed in contact with the liquid. There shall be no submerged electrical motors, bearings or fixed air piping in the aeration system. Singulair aerator motors shall be designed not to exceed the motor nameplate rating when installed and operated as recommended for the system. The fractional horsepower aerator motor shall be equipped with a foam restrictor to protect the motor against high water and foam. The motor shall be 4 pole, 1725 RPM, 115 volt, 60 Hertz, single phase, ball bearing constructed with a 1.0 service factor. It shall draw less than 4.0 amps when operating at the rated nameplate voltage. Aerator motors without UL recognition have not demonstrated compliance with international electrical standards for safety and reliability and shall not be considered for this application.

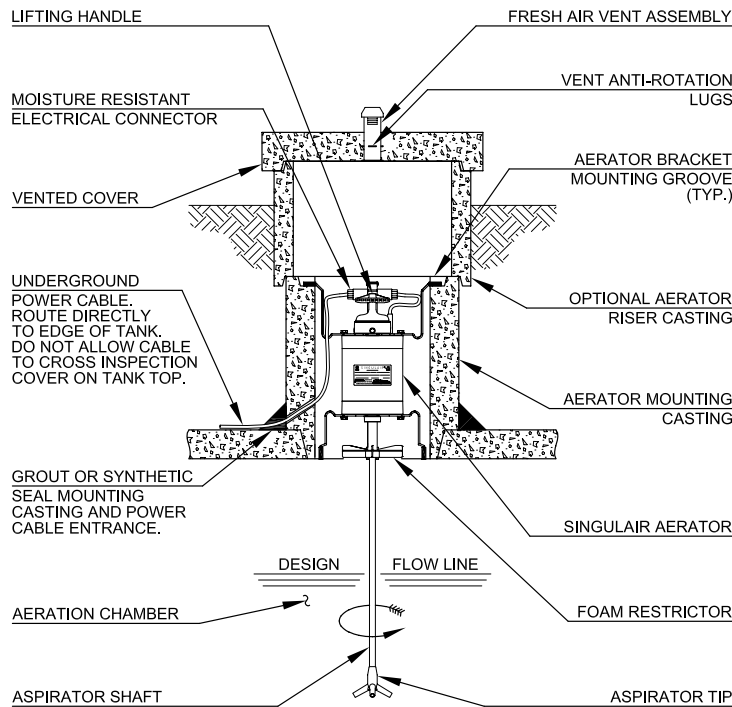

# BIO-KINETIC®

## SERVICE PRO® CONTROL CENTER

The Service Pro electrical control center with MCD technology shall provide Monitoring, Compliance and Diagnostic functions for the Singulair treatment plant using a microprocessor based platform. The Service Pro control center shall contain nonvolatile memory to prevent loss of programming in the event of a power failure. The pre-wired controls shall be mounted in a lockable NEMA rated enclosure designed specifically for outdoor use. Each Service Pro control center shall be a UL listed assembly and shall include a factory-programmed timer, alarm light, reset button, power switch, power light, phone light, aerator alarm light and three auxiliary alarm lights. The control center shall monitor all treatment system operating conditions including aerator over current, aerator under current and open motor circuit. In the event the control center detects one of these conditions, power to the aerator shall be interrupted, a diagnostic sequence shall begin and the visual alarm shall activate. After a programmed recovery interval, an automatic restart attempt shall be initiated. If normal aerator operation does not resume during 24 programmed recovery and restart cycles, the audible alarm shall activate and the telemetry system shall report the specific condition to the Service Pro monitoring center. In the event that any of the auxiliary inputs detect abnormal operation of the treatment system auxiliary equipment, the audible and visual alarms shall immediately activate and the telemetry system shall report the alarm condition to the monitoring center. The service provider shall automatically be notified by the Service Pro monitoring center of the specific alarm condition using phone, fax or email.

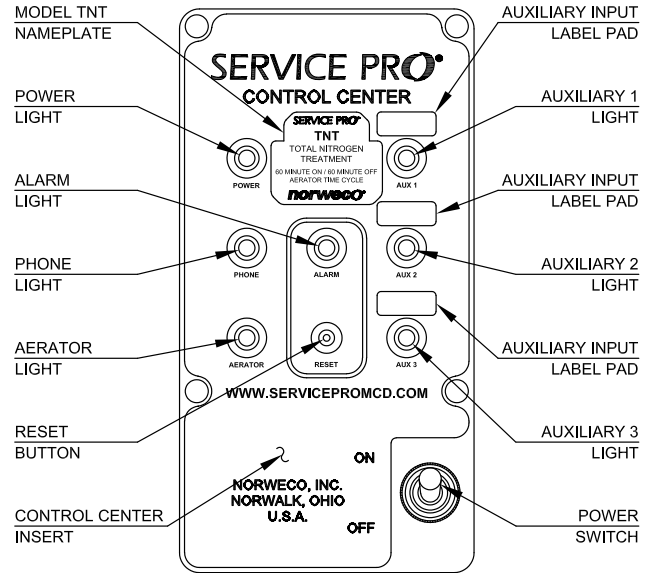

Use of an aerator timer can seriously affect system performance and operating cost. Systems that have not been performance certified, at a timed aeration cycle, by an independent ANSI accredited testing laboratory shall not be considered for this application.

## AERATOR TIME CYCLE

A factory-programmed timer built into the Service Pro control center shall provide a total of twelve hours of aerator operation per day. The non-adjustable timer shall create a 60 minute aeration cycle followed by a 60 minute anoxic cycle during which the aerator shall be off.

Systems that have not been performance certified, at a timed aeration cycle, by an independent ANSI accredited testing laboratory shall not be considered for this application.

The screenshot shows the Service Pro monitoring website. At the top, it says 'SERVICE PRO powered by MCD technology'. Below this is a navigation bar with links for 'search', 'service due', 'panel info', 'alarm state', 'faq', and 'norweco.com'. The main content area is divided into several sections: 'accounts' with a list of actions like 'add new subscriber', 'view/edit subscriber', etc.; 'history' with 'specific account', 'all active accounts', etc.; 'reports' with 'add service report', 'upload pdf document', etc.; 'downloads' with 'singulair downloads', 'hydro-kinetic downloads'; 'aerator exchange' with 'exchange calculator'; and 'administration' with 'distributor', 'service provider', 'user internet access'. There is a 'quick account search' section with a 'DISTRIBUTORA' user and an email field. A central message says 'Welcome, Onsite Professional!' and provides instructions on how to use the navigation menu. A 'Service Pro control center' image is shown with a 'To learn more about the features offered by the Service Pro control center, click here.' link. At the bottom, there are links for 'home', 'contact us', 'help', and 'log off', along with the copyright notice '© 2010 Service Pro Monitoring Inc. All Rights Reserved' and the website URL 'www.servicepromcd.com'.

## SERVICE PRO® MONITORING CENTER

The Service Pro monitoring center shall include a 256 bit encrypted password protected website for interface with the monitoring center database. Access to the secure website shall be obtained through a unique user name and password that provides tiered access to data from monitored treatment systems. Access level tiers shall include distributors, service providers, regulatory agencies and individual system owners. Distributors and service providers shall be able to create accounts, maintain service records and grant regulatory agencies access to the information. Individual system owners shall be able to view information regarding their own wastewater treatment systems, as well as download and print instructional information. Integrity of stored data shall be maintained through the use of multiple servers operating in geographically isolated locations.

# SPECIFICATIONS

## BIO-KINETIC® SYSTEM

A Bio-Kinetic system shall be installed in the mounting casting(s) above the clarification chamber. Each Bio-Kinetic system shall provide non-mechanical flow equalization through all plant processes including pretreatment, aeration, clarification, tertiary filtration, chlorination and dechlorination. The assembly shall be supplied with locking lugs and removable moisture/vapor shield and shall consist of a design flow and peak flow micronically molded filter, baffled perimeter settling zone, flow distribution deck, lifting handles, level indicator, adjustment lugs, optional chlorination feed tube, unbaffled perimeter settling zone, solids contact zone, vertical inlet zone, compartmented settling zone consisting of 42 baffled chamber plates, effluent stilling well, final discharge zone, adjustable outlet weir, optional dechlorination feed tube, outlet zone and gasketed discharge flange. All components shall be manufactured from inert synthetic materials or rubber, assembled in circular fashion and connected to a plastic outlet coupling. The outlet coupling shall accept a 4" diameter, Schedule 40, PVC pipe. Each Bio-Kinetic system shall be installed with the inverts of the design flow equalization ports located at the normal liquid level of the clarifier. If intermittent flow rates exceed the capacity of the design flow ports, flow shall be held upstream until the intermittent flow dissipates. If the intermittent flow continues to increase, the liquid level may reach a pair of sustained flow equalization ports. With four ports in use, flow through the system increases while continuing to provide flow equalization to all upstream and downstream processes. Peak flow equalization ports are supplied but should not be required in a properly sized system. Optional Blue Crystal and Bio-Neutralizer tablet feed tubes shall be positioned such that the flow-activated chemical cannot make contact with the liquid upstream of the feed tubes.

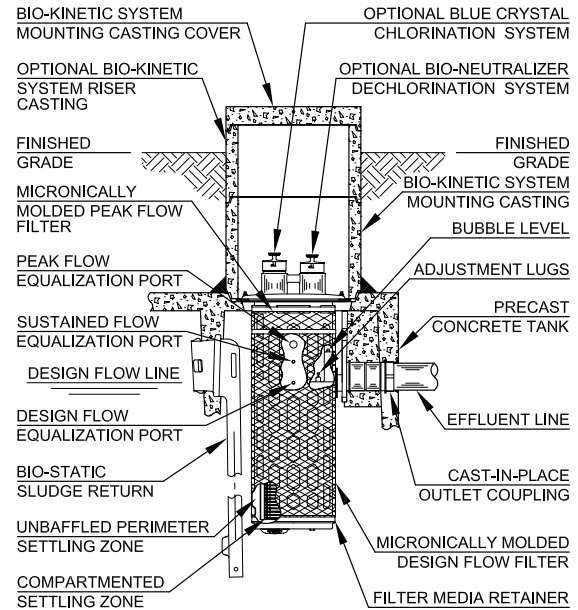

## FLOW EQUALIZATION

The wastewater treatment system shall include a non-mechanical, demand use, flow equalization device. The device shall control normal residential flow rates and reduce typical residential flow surges. The flow equalization rate shall be dependent upon the specific loading pattern and the duration of flow surges. At the 600 gallon per day design loading schedule of NSF Standard 40 and NSF Standard 245, minimum performance of the device shall equalize daily flow an average of 50%.

## BLUE CRYSTAL® CHLORINATION SYSTEM (Optional)

The Singlair system shall be furnished complete with a tablet feeder and a six month supply of Blue Crystal disinfecting tablets. Blue Crystal tablets shall be specifically formulated for consistent chlorine dosage and effluent disinfection to the sustained, variable and intermittent flows that are typical of domestic wastewater treatment systems. The tablets shall be manufactured from pure calcium hypochlorite and contain a minimum of 70% available chlorine. Each tablet shall be 2<sup>5</sup>/<sub>8</sub>" diameter, compressed to a 1" thickness, weigh approximately 5 ounces and be white in color with blue crystals for easy identification. The tablets shall dissolve in direct proportion to the flow rate, releasing controlled amounts of chlorine.

## BIO-NEUTRALIZER® DECHLORINATION SYSTEM (Optional)

The Singlair system shall be furnished complete with a tablet feeder and a six month supply of Bio-Neutralizer dechlorination tablets. The dechlorination tablets shall contain active ingredients specially formulated to chemically neutralize both free and combined chlorine. Each tablet shall be 2<sup>5</sup>/<sub>8</sub>" diameter, compressed to a 1<sup>3</sup>/<sub>16</sub>" thickness, weigh approximately 5 ounces and be green in color for easy identification. The tablets shall dissolve slowly, releasing controlled amounts of chemical for the instantaneous removal of residual chlorine from the system effluent.

## WARRANTY AND EXCHANGE PROGRAM

The manufacturer shall provide a three year limited warranty for each Singulair aerator, Service Pro control center and Bio-Kinetic system purchased from the manufacturer. A comprehensive exchange program offers Singulair owners a lifetime of equipment protection. The distributor shall provide warranty and exchange program details to the regulatory agency, contractor and customer as required.



## EQUIPMENT MANUFACTURER

The equipment specified herein shall be the product of a manufacturer having a minimum of seven years experience in the construction of prefabricated wastewater treatment equipment and systems. Bids shall be prepared on the basis of the equipment and material specified herein for purposes of determining the low bid. This is not done, however, to eliminate other products or equipment of equal quality and efficiency. If equipment is to be substituted, approval of such substitution must be made prior to execution of any order. It is assumed that substitution will result in a reduction of cost to the contractor and that if accepted, these savings will be passed along by a reduction in the base bid.

## SINGULAIR® MODEL TNT® DATA CHART

Designation: Model TNT	500 GPD	750 GPD	1000 GPD	1250 GPD	1500 GPD
Daily Treatment Capacity (Gallons Per Day)	500/600	750/800	1000	1250	1500
Total System Capacity (Gallons)	1300	1600	2300	2850	3400
Number of Singulair Aerators	1	1	2	2	2
Number of Bio-Kinetic Systems	1	2	2	3	3
Number of Bio-Static Sludge Returns	1	1	1	2	2
Drawing Number (PC-5-)	7103	7065	7067	7068	7069

## PROGRESS THROUGH SERVICE SINCE 1906

***norweco***®

*Engineering the future of water  
and wastewater treatment*

220 REPUBLIC STREET  
NORWALK, OHIO, U.S.A. 44857  
TELEPHONE (419) 668-4471  
FAX (419) 663-5440  
[www.norweco.com](http://www.norweco.com)

**DISTRIBUTED LOCALLY BY:**

Norweco®, Norweco.com®, Singulair®, Modulair®, Travalair®, Singulair R3®, Singulair Green®, Ribbit Rivet®, Hydro-Kinetic®, Hydro-Kinetic Bio-Film Reactor®, Evenair®, Lift-Rail®, Microsonic®, Bio-Dynamic®, Bio-Sanitizer®, Bio-Neutralizer®, Bio-Kinetic®, Bio-Static®, Bio-Gem®, Bio-Max®, Bio-Perc®, Blue Crystal®, Phos-4-Fade®, Enviro-C®, Nitro-Buster®, ClearCheck®, ChemCheck®, Tri-Max®, Hydra-Max®, Service Pro®, MCD®, TNT®, WASP®, Grease Buster® and "BUSTER" logo® are registered trademarks of Norwalk Wastewater Equipment Company, Inc.

©MMXXI NORWECO, INC / REV. 10/2021

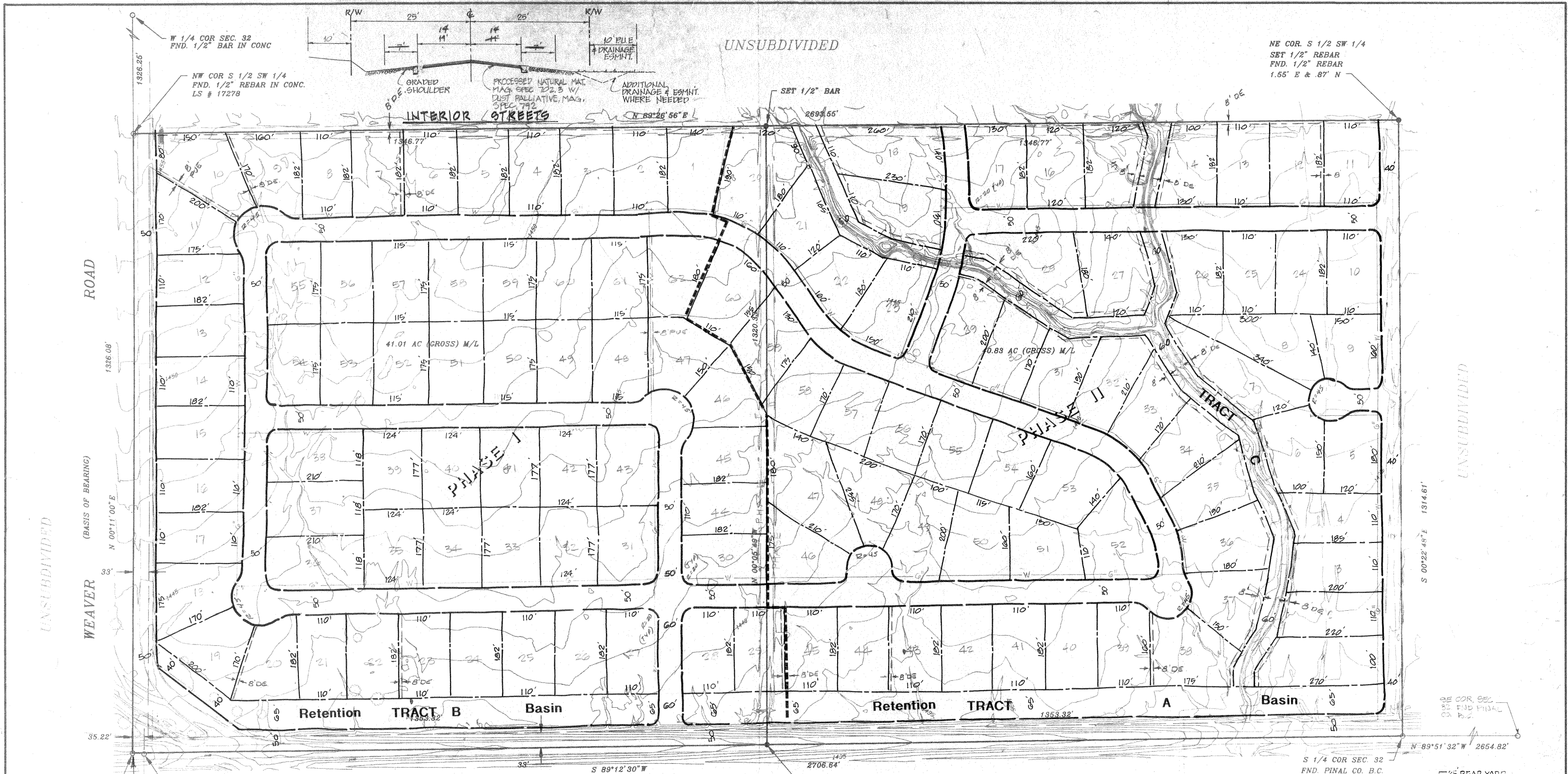

SW COR SEC. 32  
FND. 1/2" I BAR  
BENCH MARK  
TOP 1/2" I BAR  
ELEVATION =  
1444.0 ASSUMED

PER PINAL CO. TIES  
C.C. FND. PINAL CO. B.C.  
0.18' S OF TRUE CORNER  
(TRUE CORNER NOT SET)

TYPICAL LOT SIZE 20,000 sq. ft.  
TOTAL NO. OF LOTS 122  
PHASE - I 62 LOTS  
PHASE - II 60 LOTS

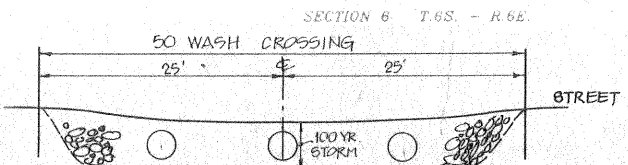

TYPICAL CULVERT & DIP SECT.  
AT WASH CROSSING

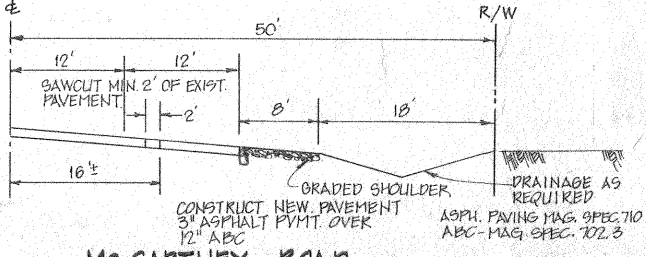

Mc CARTNEY ROAD

UNSUBDIVIDED  
**PRELIMINARY PLAT OF  
THE RIDGE AT BLACK BUTTE**

OR PART OF  
**S 1/2 SW 1/4 SECTION 32  
T.5S. - R.7E., G.&S.R.B.&M.  
PINAL COUNTY, ARIZONA**  
SURVEYED DURING THE MONTH OF AUGUST 1996

FOR  
**DICK HANSON**  
2999 N. 44th Street  
Phoenix, AZ 85018  
TEL. 602-955-4000  
FAX. 602-397-4874

NOTE: THIS SURVEY WAS MADE IN ACCORDANCE WITH LEGAL DESCRIPTIONS AND INSTRUCTIONS FURNISHED BY THE CLIENT. ANY DRAWINGS PRODUCED AS A RESULT OF THIS SURVEY ARE INSTRUMENTS OF SERVICE AND SHALL REMAIN THE PROPERTY OF WECKERLY & ASSOCIATES. ANY UNAUTHORIZED REPRODUCTION OR USE OF THESE DRAWINGS IS STRICTLY PROHIBITED. COPYRIGHT 1996 BY WECKERLY & ASSOCIATES.

- LEGEND**
- = FOUND 1/2" IRON BAR (UNLESS OTHERWISE NOTED)
  - = SET 1/2" IRON BAR (UNLESS OTHERWISE NOTED)
  - C.P. = COTTON PICKER SPINDLE
  - B.C. = BRASS CAP
  - H.H. = HAND HOLE
  - M/L = MORE OR LESS
  - C.L.D. = CONCRETE LINED DITCH
  - AC. = ACRE
  - P.P. = POWER POLE
  - 8'DE = CONTOUR LINE (1' INTERVAL)
  - ↓ = DRAINAGE EASE
  - ↑ = PUBLIC UTILITY EASE

SCALE:  
1" = 100'

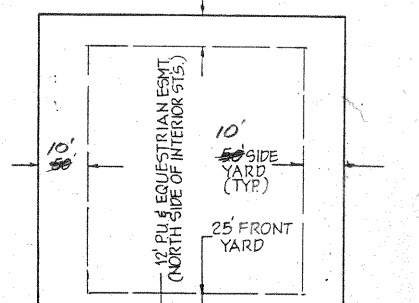

TYPICAL SETBACKS & EASEMENTS  
N.T.S.



**WECKERLY & ASSOCIATES**  
SURVEYORS—ENGINEERS

337 N. ARIZONA AVENUE  
CHANDLER, ARIZONA  
602-963-6481  
JOB NO. 960814

DICK HANSON (602) 922-1810

# New proposed Layout



Site Data	
Gross Area	78.74 acres
Existing Comp. Plan	MLD (1 - 3.5 du/ac)
Existing Zoning	CR-1 (PZ-042-96)
Proposed Lot Size	20,000 SF
Total Yield	120
Density Provided	1.52 du/ac

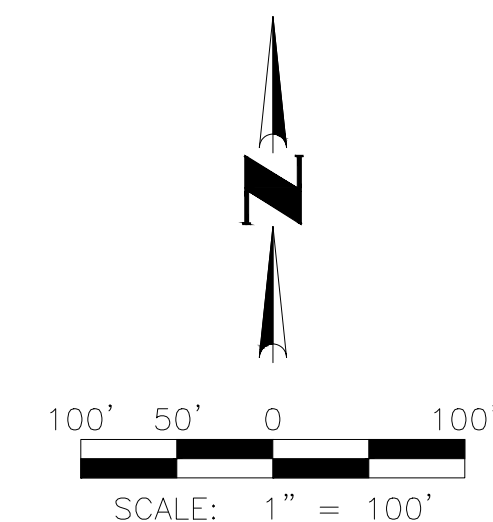

NO.	REVISION	DATE
<b>CONCEPTUAL LOTTING PLAN</b> <b>THE RIDGE AT BLACK BUTTE</b> PINAL COUNTY, ARIZONA		
<b>Coe &amp; Van Loo Consultants, Inc.</b>		
SHEET 01 OF 01 CVL Contact: ALEX CARAVEO CVL Project #: 01_0408701 <small>© 2023 Coe &amp; Van Loo Consultants, Inc. All rights reserved for reproduction in any format.</small>		