



MEETING DATE: OCTOBER 26, 2022

TO: BOARD OF SUPERVISORS

CASE NO.: **PZ-042-21, & PZ-PD-042-21, (VENIDA)**

CASE COORDINATOR: Evan Evangelopoulos

Executive Summary:

HAM PAPAGO LLC/Harry Zeitlin, landowner and CVL Consultants/Julie Vermillion, applicant/agent, requesting approval of a rezoning from CB-1 (Local Business Zone) and CR-3 (Single Residence Zone) to R-7 (Single Residence Zoning District) to allow a single-family residential development on ±158.25 acres of land, as part of the Venida Subdivision Development; and requesting approval of an amendment to the Venida Planned Area Development (PAD) (PZ-PD-023-06/PZ-023-06), on 158.25±-acres of land, from R-7 to R-7/PAD, and allow for a master planned community of 544± lots; located at the southeast corner of Papago and North Green Roads, about 8 miles from the westernmost boundary of Pinal County and two miles west and one mile south of the Ak Chin Indian Community of the Maricopa Indian Reservation, in Pinal County.

If This Request is Approved:

The applicant will apply for a site plan review under the new development and design standards.

Staff Recommendation/Issues for Consideration/Concern:

The Community Development Director recommends approval of the Venida Subdivision Development; Rezoning and Planned Area Development (PAD) applications with attached stipulations.

LEGAL DESCRIPTION: A portion of the Northwest Quarter of Section 21, Township 5 South, Range 3 East of G&SRB&M, Pinal County, AZ.

TAX PARCELS: 510520030 & 510520020 (legal on file)

LANDOWNER: HAM PAPAGO LLC/Harry Zeitlin

APPLICANT/AGENT: CVL Consultants/Julie Vermillion, applicant/agent.

REQUESTED ACTIONS & PURPOSE:

PZ-042-21 - PUBLIC HEARING/ACTION: HAM PAPAGO LLC/Harry Zeitlin, landowner and CVL Consultants/Julie Vermillion, applicant/agent, requesting approval of a rezoning from **CB-1 (Local Business Zone) and CR-3 (Single Residence Zone)** to **R-7 (Single Residence Zoning District)** to allow a

single-family residential development on 158.25± acres of land, as part of the Venida Subdivision Development; situated in that part of the Northwest Quarter of Section 21, Township 5 South, Range 3 East of G&SRB&M, Pinal County, AZ; tax parcel 510520030 (legal on file); located at the southeast corner of Papago and North Green Roads, about 8 miles from the westernmost boundary of Pinal County and two miles west and one mile south of the Ak Chin Indian Community of the Maricopa Indian Reservation, in Pinal County.

PZ-PD-042-21 – PUBLIC HEARING/ACTION: HAM PAPAGO LLC/Harry Zeitlin, landowner and CVL Consultants/Julie Vermillion, applicant/agent, requesting approval of an amendment to the **Venida Planned Area Development (PAD)** (cases #PZ-023-06/PZ-PD-023-06), to allow a 544-lot single-family residential development on 158.25± acres of land, as part of the Venida Subdivision Development; situated in that part of the Northwest Quarter of Section 21, Township 5 South, Range 3 East, of G&SRB&M, Pinal County, AZ; tax parcels 510520030 and 510520020 (legal on file); located at the southeast corner of Papago and North Green Roads, about 8 miles from the westernmost boundary of Pinal County and two miles west and one mile south of the Ak Chin Indian Community of the Maricopa Indian Reservation, in Pinal County.

LOCATION: The subject site is located at the southeast corner of Papago and North Green Roads, about 8 miles from the westernmost boundary of Pinal County and two miles west and one mile south of the Ak Chin Indian Community of the Maricopa Indian Reservation, in Pinal County.

DEVELOPMENT AREA: 158.25± acres

DEVELOPMENT UNITS: 544

Lot Mix		
	Approved	Proposed
45' x 120'	-	± 388 lots
48' x 115'	220 lots	-
55' x 120'	-	± 156 lots
58' x 115'	190 lots	-
68' x 120'	92 lots	-
Total *	502 lots	± 544 lots

COMPREHENSIVE PLAN DESIGNATION: Moderate Low Density Residential 1-3.5du/ac. Proposed density is at 3.44 du/ac.

EXISTING ZONING AND USE: The subject site is zoned **CB-1 (Local Business Zone)** and **CR-3 (Single Residence Zone)** (PZ-PD-023-06/PZ-023-06). The current use is vacant land/desert/fallow land.

SURROUNDING ZONING AND LAND USE:
 North: GR General Rural, agriculture.

South: GR General Rural, agriculture.
East: GR General Rural, agriculture.
West: CR-3 (Single Residence Zone), agriculture.

PUBLIC PARTICIPATION:

Neighborhood Meeting: September 9, 2021
Agency mail out: June 17, 2022
Newspaper Advertising: September 22, 2022
Site posting, Applicant: June 20, 2022

SITE DATA/FINDINGS:

FLOOD ZONE: The subject site is in Flood Zone "X" of minimal flood hazard.

ACCESS: The site will be accessed from Papago Road to the north, Green Road to the west, and future roads to the east and south. Overall, the development is proposing 6 access points.

HISTORY/ANALYSIS: The subject site is presently owned by HAM PAPAGO LLC/Harry Zeitlin. It was initially zoned CB-1/PAD and CR-3/PAD and approved under cases #PZ-PD-023-06 with 45 stipulations and PZ-023-06 with 9 stipulations. The site was never developed, however, and has remained agricultural. Although the County overall does not condone the conversion of commercial property to residential, the applicant is offering a market analysis to justify the conversion of the existing CB-1 zone to residential.

The project offers a total of 544 lots with a density of 3.44 du/ac, and 18% of open space to County requirements.

As of today, two public comments have been received in the Planning Division regarding the project via e-mail and via direct contact with a resident at the Pinal County hearing room during the July 21 Planning and Zoning Commission meeting. Additional concerns were expressed at the postponed, due to lack of quorum, August 18 Planning and Zoning Commission hearing. Overall concerns expressed were about:

- Traffic increases and accidents,
- Light pollution at night,
- Increased density in a low density area,
- High density development in a rural area where residents enjoy their horses and livestock,
- Preservation of the rural way of life,
- Concerns of 'turning into Maricopa,'
- Concerns about ruining the rural way of life and becoming a city.

STAFF SUMMARY: HAM PAPAGO LLC/Harry Zeitlin, landowner and CVL Consultants/Julie Vermillion, applicant/agent, have submitted the proper applications and evidence sufficient to warrant a staff recommendation as provided in the Ordinance. Staff provides the following summary and findings together with the information on the previous pages of this staff report:

1. The submitted applications for this land use request are for approval of a rezoning, and a PAD.
2. If the applications are approved, the subject property will be rezoned from **CB-1 (Local Business Zone) and CR-3 (Single Residence Zone)** to **R-7/PAD (Single Residence Zoning District)** and allow the development of 544 lots on 158.25± acres of land.
3. To date, some opposition to the project has been received, concerning mainly densities, traffic, and change of rural character.
4. The property has legal access.
5. The property complies with the density of the Pinal County Comprehensive Plan.
6. Granting of the rezoning and PAD, will require after the time of approval, that the applicant/owner submit and secure from the applicable and appropriate Federal, State, County and Local regulatory agencies, all required applications, plans, permits, supporting documentation and approvals.

STAFF RECOMMENDATION (PZ-042-21 & PZ-PD-042-21): After a detailed review of the request, Pinal County Comprehensive Plan, and the Pinal County Development Services Code (PCDSC), staff recommends approval of this request, subject to the stipulations listed in the recommended motion.

COMMISSION ACTION/RECOMMENDATION (PZ-042-21 & PZ-PD-042-21): At the hearing, after discussion with staff and the Commission, together with evidence presented & public testimony, the Commission voted 8-0 to recommend approval of **(PZ-042-21 & PZ-PD-042-21)** based upon the record as presented, with the following stipulations:

PZ-042-21: APPROVAL with one (1) stipulation:

1. Approval of this zone change (PZ-042-21) will require, at the time of application for development, that the applicant/owner submit and secure from the applicable and appropriate Federal, State, County and Local regulatory agencies, all required applications, plans, permits, supporting documentation and approvals.

PZ-PD-042-21: APPROVAL with six (6) stipulations:

1. Development standards proposed and stipulations listed herein pertain to the area described in case PZ-PD-042-21 and supersede development standards and relevant stipulations under cases #PZ-PD-023-06 and #PZ-023-06.
2. All peripheral road and infrastructure improvements shall be per the approved Traffic Impact Analysis to mitigate impacts on all surrounding roadways to be completed at the developer's cost. These may include construction of acceleration/deceleration lanes, left turn pockets, traffic signals or other public improvements as approved by the County Engineer. The TIA shall be in accordance with the current Pinal County TIA Guidelines and Procedures and shall be approved prior to the Tentative Plat being scheduled for the Planning Commission;
3. A drainage report will be required to be submitted to the County Engineer for review and approval. The drainage report shall comply with the current Pinal County Drainage Manual and shall be

approved prior to any Final Plat approval. The approved Drainage Plan shall provide retention for storm waters in an onsite retention/common retention area or as approved by the County Engineer;

4. Half street right-of-way dedication and half street road improvements will be required for PAPAGO ROAD (northern boundary), GREEN ROAD (western boundary) and both the southern and eastern boundary roadways. The required minimum half street right-of-way is 55' for PAPAGO ROAD and GREEN ROAD and a minimum 40' for the southern and eastern boundary roadways (mid-section lines). Any additional right-of-way needed for any required infrastructure improvements (as identified in the approved Traffic Impact Analysis) for any roadways shall be the responsibility of the applicant. All roadway and infrastructure improvements shall be in accordance with the current Pinal County Subdivision Standards or as approved by the County Engineer;
5. All right-of-way dedication shall be free and unencumbered;
6. Any roadway sections, alignments, access locations and access movements shown in the PAD are conceptual only and have not been approved by the Pinal County Engineer.

Date Prepared: 10/11/2022 EE

Revised:

As of 10/13/2022, minutes of the 9/15/2022 P&Z hearing have not become available. The minutes will be provided accordingly once available.



MEETING DATE: SEPTEMBER 15, 2022

TO: PINAL COUNTY PLANNING & ZONING COMMISSION

CASE NO.: **PZ-042-21, & PZ-PD-042-21, (VENIDA)**

CASE COORDINATOR: Evan Evangelopoulos

Executive Summary:

HAM PAPAGO LLC/Harry Zeitlin, landowner and CVL Consultants/Julie Vermillion, applicant/agent, requesting approval of a rezoning from CB-1 (Local Business Zone) and CR-3 (Single Residence Zone) to R-7 (Single Residence Zoning District) to allow a single-family residential development on ±158.25 acres of land, as part of the Venida Subdivision Development; and requesting approval of an amendment to the Venida Planned Area Development (PAD) (PZ-PD-023-06/PZ-023-06), on 158.25±-acres of land, from R-7 to R-7/PAD, and allow for a master planned community of 544± lots; located at the southeast corner of Papago and North Green Roads, about 8 miles from the westernmost boundary of Pinal County and two miles west and one mile south of the Ak Chin Indian Community of the Maricopa Indian Reservation, in Pinal County.

If This Request is Approved:

The applicant will apply for a site plan review under the new development and design standards.

Staff Recommendation/Issues for Consideration/Concern:

Community Development Director recommends approval of the Venida Subdivision Development; Rezoning and Planned Area Development (PAD) applications with attached stipulations.

LEGAL DESCRIPTION: A portion of the Northwest Quarter of Section 21, Township 5 South, Range 3 East of G&SRB&M, Pinal County, AZ.

TAX PARCELS: 510520030 & 510520020 (legal on file)

LANDOWNER: HAM PAPAGO LLC/Harry Zeitlin

APPLICANT/AGENT: CVL Consultants/Julie Vermillion, applicant/agent.

REQUESTED ACTIONS & PURPOSE:

PZ-042-21 - PUBLIC HEARING/ACTION: HAM PAPAGO LLC/Harry Zeitlin, landowner and CVL Consultants/Julie Vermillion, applicant/agent, requesting approval of a rezoning from **CB-1 (Local Business Zone) and CR-3 (Single Residence Zone)** to **R-7 (Single Residence Zoning District)** to allow a

single-family residential development on 158.25± acres of land, as part of the Venida Subdivision Development; situated in that part of the Northwest Quarter of Section 21, Township 5 South, Range 3 East of G&SRB&M, Pinal County, AZ; tax parcel 510520030 (legal on file); located at the southeast corner of Papago and North Green Roads, about 8 miles from the westernmost boundary of Pinal County and two miles west and one mile south of the Ak Chin Indian Community of the Maricopa Indian Reservation, in Pinal County.

PZ-PD-042-21 – PUBLIC HEARING/ACTION: HAM PAPAGO LLC/Harry Zeitlin, landowner and CVL Consultants/Julie Vermillion, applicant/agent, requesting approval of an amendment to the **Venida Planned Area Development (PAD)** (cases #PZ-023-06/PZ-PD-023-06), to allow a 544-lot single-family residential development on 158.25± acres of land, as part of the Venida Subdivision Development; situated in that part of the Northwest Quarter of Section 21, Township 5 South, Range 3 East, of G&SRB&M, Pinal County, AZ; tax parcels 510520030 and 510520020 (legal on file); located at the southeast corner of Papago and North Green Roads, about 8 miles from the westernmost boundary of Pinal County and two miles west and one mile south of the Ak Chin Indian Community of the Maricopa Indian Reservation, in Pinal County.

LOCATION: The subject site is located at the southeast corner of Papago and North Green Roads, about 8 miles from the westernmost boundary of Pinal County and two miles west and one mile south of the Ak Chin Indian Community of the Maricopa Indian Reservation, in Pinal County.

DEVELOPMENT AREA: 158.25± acres

DEVELOPMENT UNITS: 544

Lot Mix		
	Approved	Proposed
45' x 120'	-	± 388 lots
48' x 115'	220 lots	-
55' x 120'	-	± 156 lots
58' x 115'	190 lots	-
68' x 120'	92 lots	-
Total *	502 lots	± 544 lots

COMPREHENSIVE PLAN DESIGNATION: Moderate Low Density Residential 1-3.5du/ac. Proposed density is at 3.44 du/ac.

EXISTING ZONING AND USE: The subject site is zoned **CB-1 (Local Business Zone)** and **CR-3 (Single Residence Zone)** (PZ-PD-023-06/PZ-023-06). The current use is vacant land/desert/fallow land.

SURROUNDING ZONING AND LAND USE:
 North: GR General Rural, agriculture.

South: GR General Rural, agriculture.
 East: GR General Rural, agriculture.
 West: CR-3 (Single Residence Zone), agriculture.

PUBLIC PARTICIPATION:

Neighborhood Meeting: September 9, 2021
 Agency mail out: June 17, 2022
 Newspaper Advertising: August 24, 2022
 Site posting, Applicant: June 20, 2022

SITE DATA/FINDINGS:

FLOOD ZONE: The subject site is in Flood Zone "X" of minimal flood hazard.

ACCESS: The site will be accessed from Papago Road to the north, Green Road to the west, and future roads to the east and south. Overall, the development is proposing 6 access points.

HISTORY/ANALYSIS: The subject site is presently owned by HAM PAPAGO LLC/Harry Zeitlin. It was initially zoned CB-1/PAD and CR-3/PAD and approved under cases #PZ-PD-023-06 with 45 stipulations and PZ-023-06 with 9 stipulations. The site was never developed, however, and has remained agricultural. Although the County overall does not condone the conversion of commercial property to residential, the applicant is offering a market analysis to justify the conversion of the existing CB-1 zone to residential.

The project offers a total of 544 lots with a density of 3.44 du/ac, and 18% of open space to County requirements.

Development Standards:

R-7 PAD		
	Code	Proposed
Min. Lot Area	7,000 sq. ft.	5,150 sq. ft.
Min. Lot Width	50'	45'
Min. Front Yard Setback	20'	20'*/10'*
Min. Side Yard Setback	10'	5'
Min. Rear Yard Setback	25'	15'
Max. Building Height	30'	30'
Detached Accessory Buildings		
Max. Permitted Coverage	33% of the total area of the rear and side setbacks	33% of the total area of the rear and side setbacks
Max. Height	20'	20'
Min. Distance to Main Building	7'	5'
Min. Distance to Front Lot Line	60'	60'
Min. Distance to Side and Rear Lot Lines	4'	4'

Note:* 20' from face of garage to back of sidewalk (approximately 15' to property line) and 10' to livable or side entry garage.

Utilities:

Service	Provider	Phone #	Adequacy-Status Statement
Sewer	Global Water	866-940-1102	Existing community capacities and facilities are being analyzed to determine the capability for servicing the proposed project. Proposed on-site and off-site improvements to be designed and constructed per County standards.
Water	Global Water	866-940-1102	Existing community capacities and facilities are being analyzed to determine the capability for servicing the proposed project. Proposed on-site and off-site improvements to be designed and constructed per County standards.
Service	Provider	Phone #	Adequacy-Status Statement
Electric	Arizona Public Service	602-371-7171	Existing community facilities to be determined adequate for servicing the proposed project. Proposed on-site and off-site improvements to be designed and constructed by APS.
Telephone	Century Link / Cox Communications	602-630-5480 / 623-328-3807	Existing community facilities to be determined adequate for servicing the proposed project. Proposed on-site and off-site improvements to be designed and constructed by provider.
Gas	Southwest Gas	877-860-6020	Existing community facilities to be determined adequate for servicing the proposed project. Proposed on-site and off-site improvements to be designed and constructed by provider.
Police	Pinal County Sheriff's Office	1-800-420-8689	Existing community services to be determined adequate for servicing the proposed project.
Fire	South Maricopa Facilities Association	520-723-4680	Existing community services to be extended to include the proposed project. A new fire station is proposed on a parcel directly west of the Project and south of Papago Road.
Schools	Maricopa Unified School District	520-568-5100	The Maricopa Unified School District was notified of the project via first-class mail. Correspondence with the school district will be provided to County staff.
Solid Waste	Private Hauler	480-983-9101	Existing community services to be extended to include the proposed project.

Note: Additional coordination with the above providers is necessary to confirm adequate servicing.

The **Pinal County Community Development Department Engineering Division**, the **Pinal County Air Quality Control District**, and the **Pinal County Flood Control District** have reviewed the proposal and their respective stipulations are included in this Staff Report.

As of today, two public comments have been received in the Planning Division regarding the project via e-mail and via direct contact with a resident at the Pinal County hearing room during the July 21 Planning and Zoning Commission meeting. Additional concerns were expressed at the postponed, due to lack of quorum, August 18 Planning and Zoning Commission hearing. Overall concerns expressed were about:

- Traffic increases and accidents,
- Light pollution at night,
- Increased density in a low density area,
- High density development in a rural area where residents enjoy their horses and livestock,
- Preservation of the rural way of life,
- Concerns of ‘turning into Maricopa,’
- Concerns about ruining the rural way of life and becoming a city.

The emailed letter is attached to this staff report/package

At the public hearing, the Commission needs to be satisfied that the health, safety and welfare of the County and adjacent properties will not be negatively impacted by this PAD request under planning cases #PZ-042-21, & PZ-PD-042-21. Furthermore, the Commission must determine that this zone change and PAD overlay will promote the orderly growth and development of the County, at this location and time, and that this proposed development is compatible and consistent with the applicable goals and policies of the Pinal County Comprehensive Plan and rezone request.

THE BURDEN OF PROOF IS UPON THE APPLICANT TO PROVIDE THE NECESSARY AND REQUIRED INFORMATION AT THE PUBLIC HEARING. THE APPLICANT NEEDS TO BE PREPARED TO ADDRESS AND MITIGATE, AS APPLICABLE, THE FOLLOWING ISSUES AND CONCERNS:

- A. LAND USE, PERIMETER WALLS, SIGNAGE, SETBACKS, INGRESS/EGRESS & LANDSCAPING
- B. PUBLIC SERVICES - SEWER, WATER, UTILITIES, DRAINAGE
- C. NEIGHBORHOOD IMPACT
- D. FLOOD CONTROL
- E. TRAFFIC IMPACT
- F. COMPATIBILITY/CONSISTENCY WITH PINAL COUNTY COMPREHENSIVE PLAN
- G. BENEFITS/DETRIMENTS TO PINAL COUNTY

STAFF SUMMARY: HAM PAPAGO LLC/Harry Zeitlin, landowner and CVL Consultants/Julie Vermillion, applicant/agent, have submitted the proper applications and evidence sufficient to warrant a staff recommendation as provided in the Ordinance. Staff provides the following summary and findings together with the information on the previous pages of this staff report:

1. The submitted applications for this land use request are for approval of a rezoning, and a PAD.
2. If the applications are approved, the subject property will be rezoned from **CB-1 (Local Business Zone) and CR-3 (Single Residence Zone)** to **R-7/PAD (Single Residence Zoning District)** and allow the development of 544 lots on 158.25± acres of land.
3. To date, no letters in opposition have been received.
4. The property has legal access.
5. The property complies with the density of the Pinal County Comprehensive Plan.
6. Granting of the rezoning and PAD, will require after the time of approval, that the applicant/owner submit and secure from the applicable and appropriate Federal, State, County and Local

Rezone
Land Status

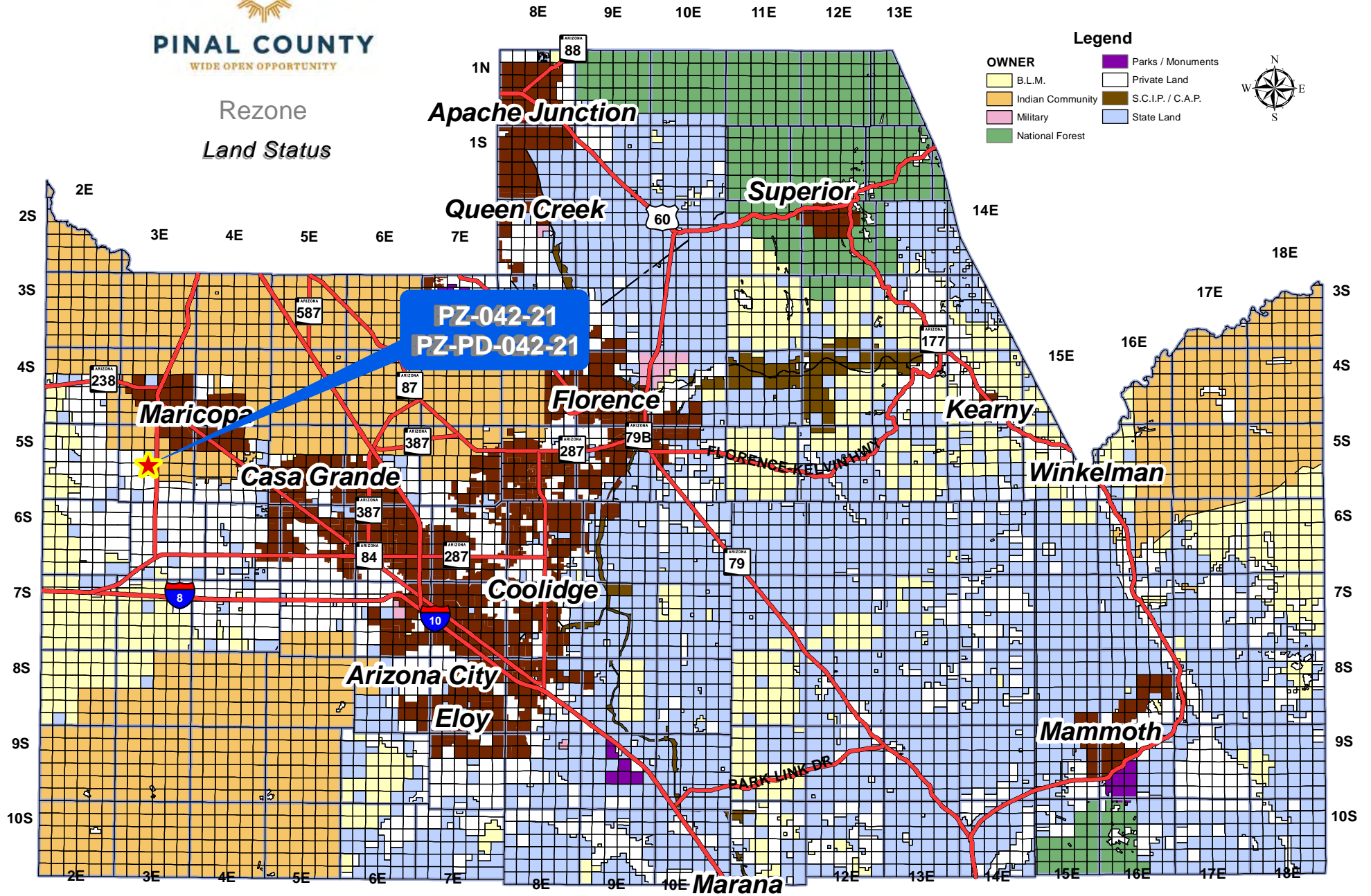

- Legend**
- | | |
|------------------|-------------------|
| OWNER | Parks / Monuments |
| B.L.M. | Private Land |
| Indian Community | S.C.I.P. / C.A.P. |
| Military | State Land |
| National Forest | |



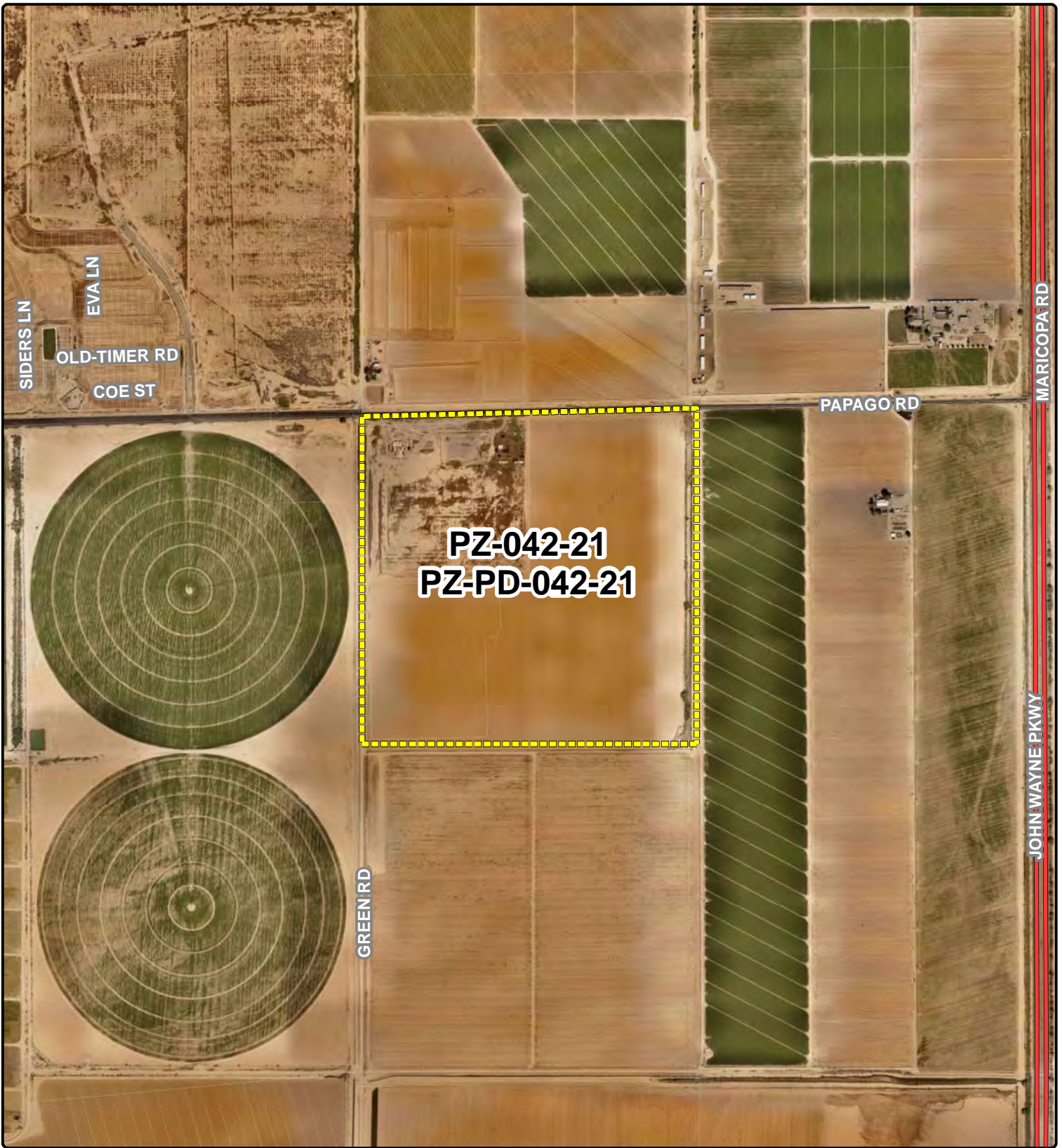

Rezone/Community Development



PZ-042-21
PZ-PD-026-21

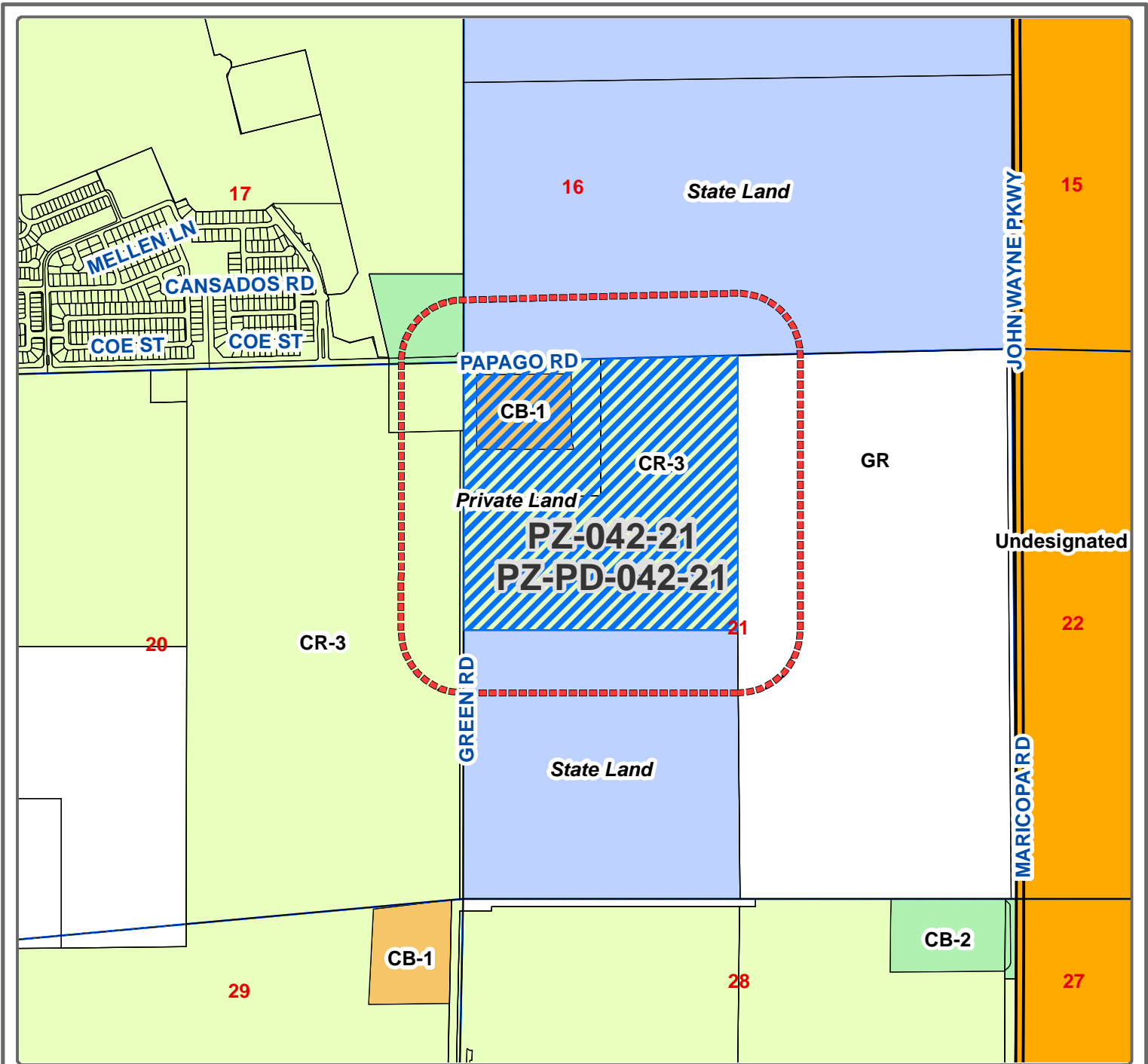

Rezone

PZ-042-21 - PUBLIC HEARING/ACTION: HAM PAPAGO LLC/Harry Zeitlin, landowner and CVL Consultants/Julie Vermillion, applicant/agent, requesting approval of a rezoning from CB-1 (Local Business Zone) to CR-3 (Single Residence Zone) to allow a single-family residential development on ±15.0 acres of land, as part of the Venida Subdivision Development; situated in that part of the Northwest Quarter of Section 21, Township 5 South, Range 3 East, of the Gila and Salt River Meridian, Pinal County, Arizona; tax parcels 510520030 and 510520020, and located at the southeast corner of Papago and North Green Roads, about 8 miles from the westernmost boundary of Pinal County and two miles west and one mile south of the Ak Chin Indian Community of the Maricopa Indian Reservation, in Pinal County.

Current Zoning: CB-1 Requested Zoning: Rezone Current Land Use: Moderate Low Density Residential (1-3.5du/ac)



Legal Description:
 Situated in that part of the Northwest Quarter of Section 21, Township 5 South, Range 3 East, of the Gila and Salt River Meridian, Pinal County, Arizona; tax parcels 510520030 and 510520020, and located at the southeast corner of Papago and North Green Roads, about 8 miles from the westernmost boundary of Pinal County and two miles west and one mile south of the Ak Chin Indian Community of the Maricopa Indian



Owner/Applicant: HAM PAPAGO LLC/HARRY ZEITLIN, LANDOWNER CVL CONSULTANTS/JULIE VERMILLION, APPLICANT/AGENT		
Drawn By: GIS / IT / SAH	Date: 6/17/2022	
Section 21	Township 05S	Range 03E
Case Number: PZ-042-21, PZ-PD-026-21		

Sheet No.
1 of 1

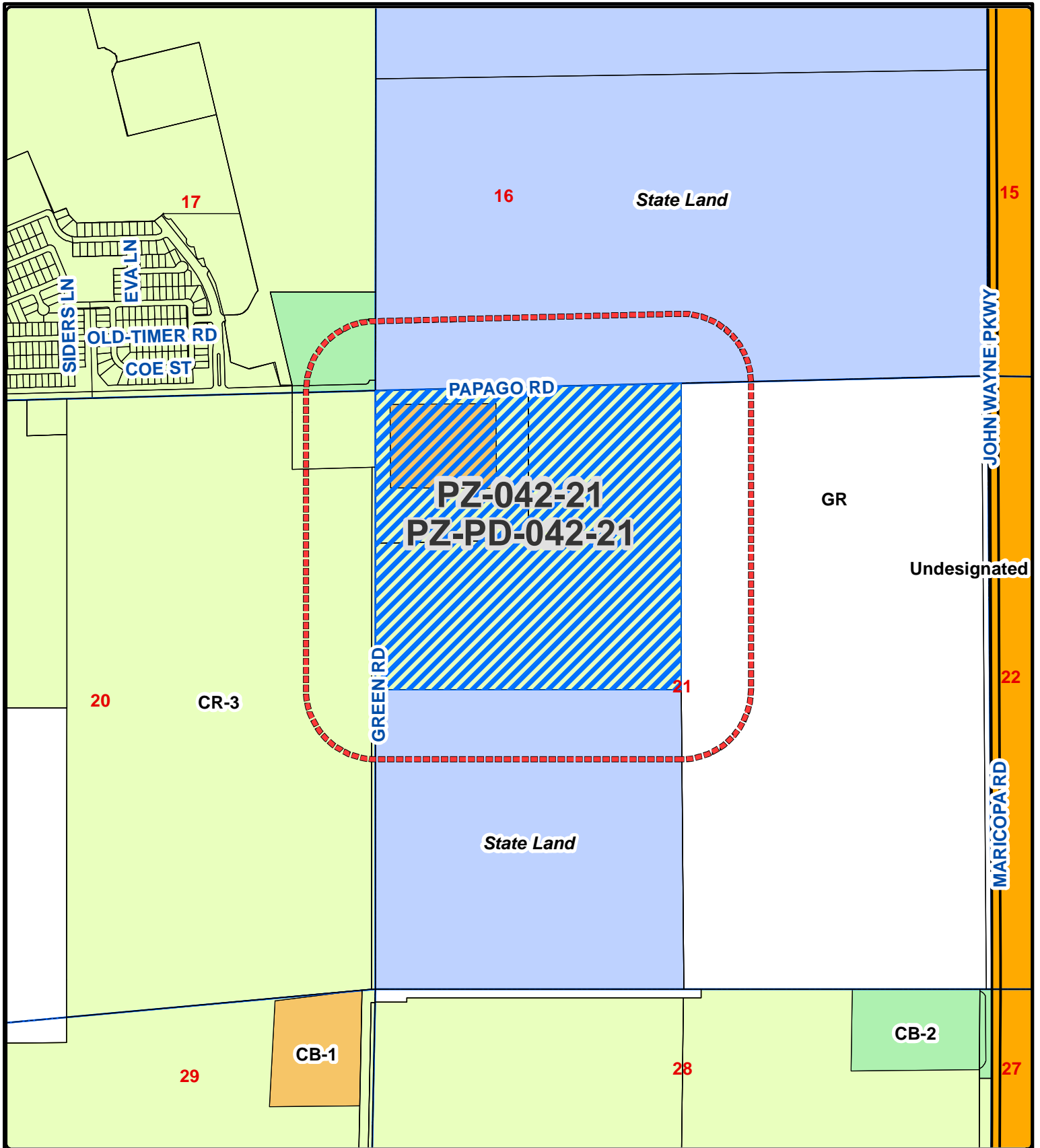

Rezone

HAM PAPAGO LLC/Harry Zeitlin, landowner CVL Consultants/Julie Vermillion, applicant/agent	Legal Description: Situated in that part of the Northwest Quarter of Section 21, Township 5 South, Range 3 East, of the Gila and Salt River Meridian, Pinal County, Arizona; tax parcels 510520030 and 510520020, and located at the southeast corner of Papago and North Green Roads, about 8 miles from the westernmost boundary of Pinal County and two miles west and one	 Sheet No. 1 of 1	 PINAL COUNTY <small>BEING OPEN AND AVAILABLE</small>	Current Zoning: CB-1 Request Zoning: Rezone Current Land Use: Moderate Low Density Residential (1-3.5 du/ac)
GIS/IT - SAH 06/17/2022	T05S-R03E Sec 21			
Section 21 Township 05S Range 03E	PZ-042-21, PZ-PD-026-21			

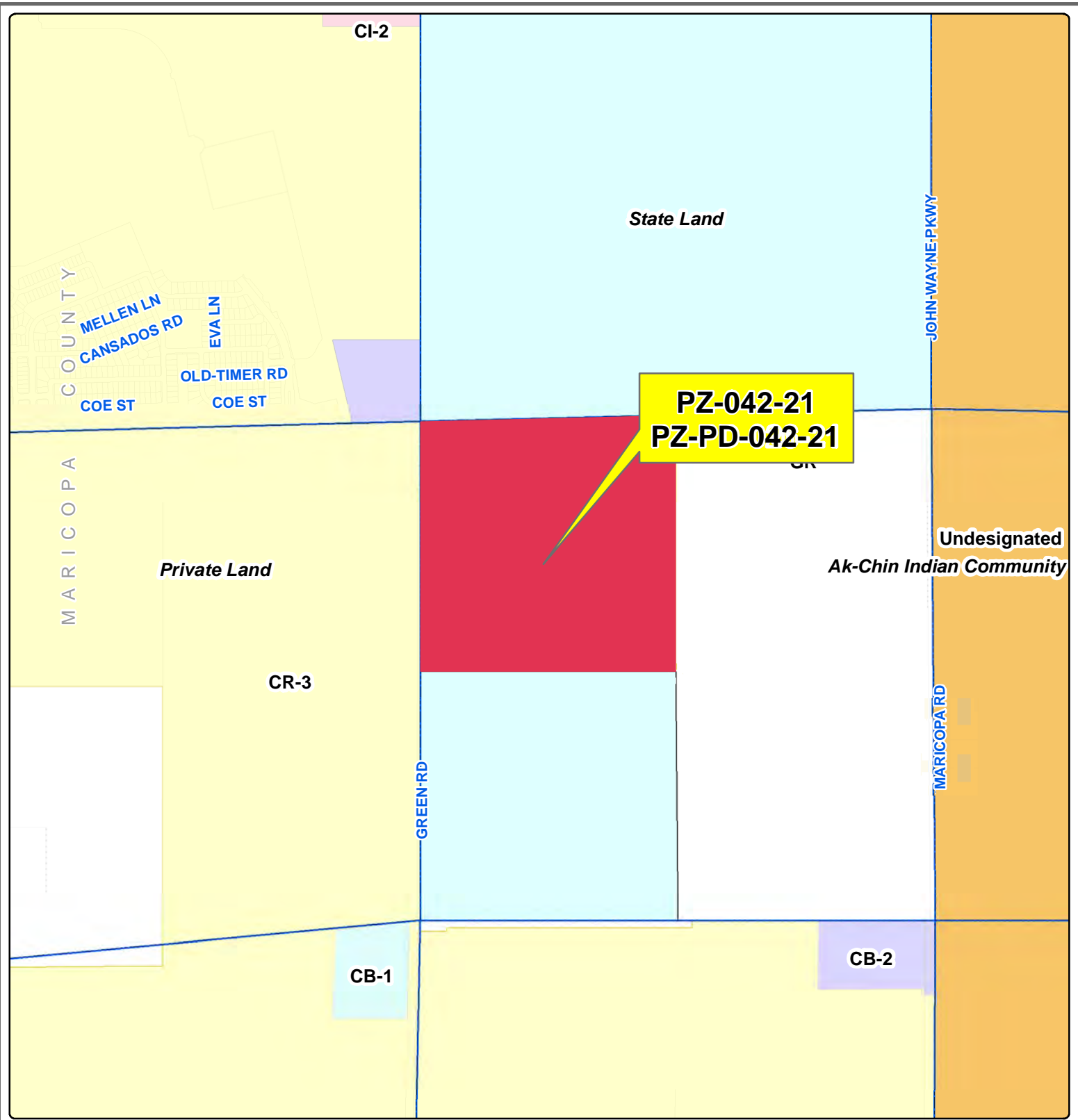

Rezone/Community Development



Legal Description: Situated in that part of the Northwest Quarter of Section 21, Township 5 South, Range 3 East, of the Gila and Salt River Meridian, Pinal County, Arizona; tax parcels 510520030 and 510520020, and located at the southeast corner of Papago and North Green Roads, about 8 miles from the westernmost boundary of Pinal County and two miles west and one mile south of the Ak Chin Indian Community of the Maricopa Indian Reservation, in Pinal County.		Owner/Applicant: HAM PAPAGO LLC/HARRY ZEITLIN, LANDOWNER CYL CONSULTANTS/JULIE VERMILLION, APPLICANT/AGENT		
		Drawn By: GIS / IT / SAH	Date: 06/17/2022	
	Sheet No. 1 of 1	Section 21	Township 05S	Range 03E
	Case Number: PZ-042-21, PZ-PD-026-21			

51048009F

51048009K

51048804A

NAP



51048009H

51048015F

PAPAGO RD

510520030

PZ-042-21
PZ-PD-042-21

510520020

51048014J

51048015G

GREEN RD

51052001A

NAP

MARICOPA RD

51048014D

510528030

JOHN WAYNE PKWY

regulatory agencies, all required applications, plans, permits, supporting documentation and approvals.

STAFF RECOMMENDATION (PZ-042-21): After a detailed review of the request, Pinal County Comprehensive Plan, and the Pinal County Development Services Code (PCDSC), staff recommends approval of this request, subject to the stipulation listed in the recommended motion.

Should the Commission find after the presentation of the applicant and together with the testimony and evidence presented at the public hearing, that this zone change (PZ-042-21) request is needed and necessary at this location and time, will not negatively impact adjacent properties, will promote orderly growth and development of the County and will be compatible and consistent with the applicable goals and policies of the Pinal County Comprehensive Plan, then staff recommends that the Commission forward PZ-042-21 to the Board of Supervisors with a favorable recommendation. If the Commission cannot approve for all of the factors listed above, then staff recommends that the Commission forward this case to the Board of Supervisors with a recommendation of denial.

STAFF RECOMMENDED MOTION (PZ-042-21): *I move the Pinal County Planning and Zoning Commission forward a recommendation of APPROVAL to the Board of Supervisors with 1 stipulation as listed in the staff report:*

1. Approval of this zone change (PZ-042-21) will require, at the time of application for development, that the applicant/owner submit and secure from the applicable and appropriate Federal, State, County and Local regulatory agencies, all required applications, plans, permits, supporting documentation and approvals.

STAFF RECOMMENDATION (PZ-PD-042-21): Staff finds, with the testimony and evidence provided and presented, that this PAD request will not negatively impact adjacent properties, will promote orderly growth and development of the County, and will be compatible with the applicable goals, policies, and suggestions of the Pinal County Comprehensive Plan, and staff recommends that the Commission forward PZ-PD-042-21 to the Board of Supervisors with a favorable recommendation with the attached stipulations.

Should the Commission find after the presentation of the applicant and together with the testimony and evidence presented at the public hearing, that this PAD request is needed and necessary at this location and time, will not negatively impact adjacent properties, will promote orderly growth and development of the County, and will be compatible and consistent with the applicable goals and policies of the Pinal County Comprehensive Plan, then staff recommends that the Commission forward PZ-PD-042-21 to the Board of Supervisors with a favorable recommendation with the attached stipulations. If the Commission cannot approve for all of the factors listed above, then staff recommends that the Commission forward this case to the Board of Supervisors with a recommendation of denial.

STAFF RECOMMEND MOTION (PZ-PD-042-21): *I move the Pinal County Planning and Zoning Commission forward a recommendation of APPROVAL to the Board of Supervisors with its 6 stipulations as listed in the staff report:*

1. Development standards proposed and stipulations listed herein pertain to the area described in case PZ-PD-042-21 and supersede development standards and relevant stipulations under cases #PZ-PD-023-06 and #PZ-023-06.
2. All peripheral road and infrastructure improvements shall be per the approved Traffic Impact Analysis to mitigate impacts on all surrounding roadways to be completed at the developer's cost. These may include construction of acceleration/deceleration lanes, left turn pockets, traffic signals or other public improvements as approved by the County Engineer. The TIA shall be in accordance with the current Pinal County TIA Guidelines and Procedures and shall be approved prior to the Tentative Plat being scheduled for the Planning Commission;
3. A drainage report will be required to be submitted to the County Engineer for review and approval. The drainage report shall comply with the current Pinal County Drainage Manual and shall be approved prior to any Final Plat approval. The approved Drainage Plan shall provide retention for storm waters in an onsite retention/common retention area or as approved by the County Engineer;
4. Half street right-of-way dedication and half street road improvements will be required for PAPAGO ROAD (northern boundary), GREEN ROAD (western boundary) and both the southern and eastern boundary roadways. The required minimum half street right-of-way is 55' for PAPAGO ROAD and GREEN ROAD and a minimum 40' for the southern and eastern boundary roadways (mid-section lines). Any additional right-of-way needed for any required infrastructure improvements (as identified in the approved Traffic Impact Analysis) for any roadways shall be the responsibility of the applicant. All roadway and infrastructure improvements shall be in accordance with the current Pinal County Subdivision Standards or as approved by the County Engineer;
5. All right-of-way dedication shall be free and unencumbered;
6. Any roadway sections, alignments, access locations and access movements shown in the PAD are conceptual only and have not been approved by the Pinal County Engineer.

Date Prepared: 08/03/2022 EE

Revised: 09/08/2022 EE

Proposed Site Plan

Exhibit H

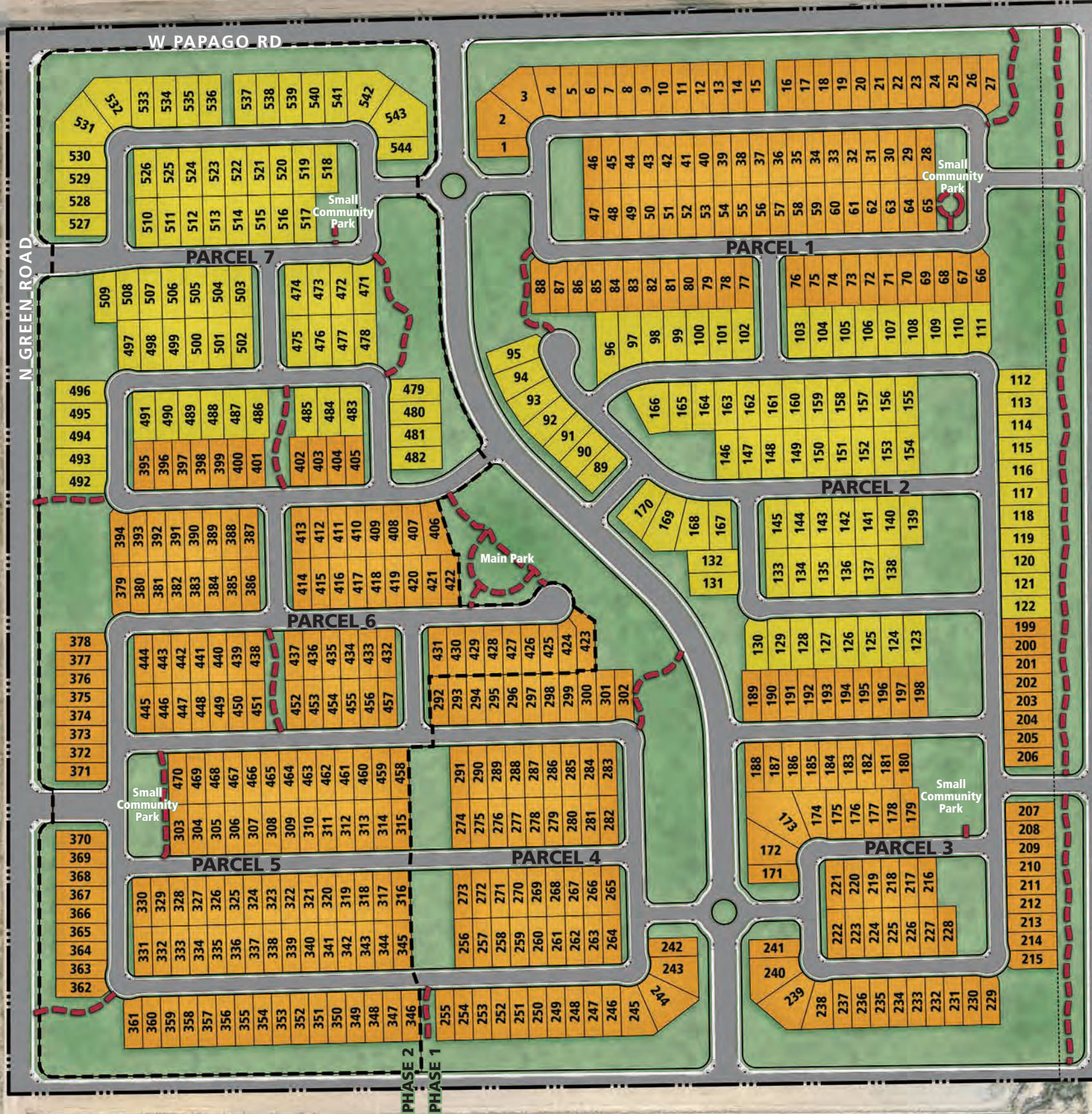

LEGEND

- 55' x 120'
- 45' x 120'
- Open Space
- Trails

SITE DATA		
Gross Area	158.25 acres	
Zoning	R-7/PAD	
Max. Density Permitted	3.50 du/ac	
Approximate Density Provided	± 3.44 du/ac	
Approximate Number of Lots	45' x 120'	± 388 lots
	55' x 120'	± 156 lots
	Total	± 544 lots
Open Space Required	± 28.48 acres	± 18%

SITE COMPARISON				
Site Data	Existing Plan		Proposed Plan	
Gross Area	158.50 acres		158.25 acres	
Commercial Area	15.00 acres		0.00 acres	
Residential Area	143.50 acres		158.25 acres	
Zoning	CR-3/PAD & CB-1/PAD		R-7/PAD	
Max. Density Permitted	3.50 du/ac		3.50 du/ac	
Approximate Density Provided	3.50 du/ac		± 3.44 du/ac	
Open Space Required	21.53 acres	15%	± 28.48 acres	± 18%
Lot Mix	Existing Plan		Proposed Plan	
45' X 120'			± 388 lots	± 71%
48' X 115'	220 lots	44%		
55' X 120'			± 156 lots	± 29%
58' X 115'	190 lots	38%		
68' X 120'	92 lots	18%		
Total	502 lots	100%	± 544 lots	100%

Note: Final lot counts, density, open space, and individual parcel data are subject to change and will be finalized during the Tentative Plat and Final Plat processes.



September 27, 2021
Revised: April 20, 2022



Planned Area Development
Pinal County, Arizona

**PLANNED AREA DEVELOPMENT
AMENDMENT NARRATIVE**

Case #: PZ-PD-042-21



4550 N 12th Street
Phoenix, AZ 85014
CVL Job. No: 1-01-03723-01

Planned Area Development Amendment

**for
Venida**

Pinal County, Arizona

Case #: PZ-PD-042-21

Developer

LGI Homes – Arizona, LLC

9105 East Del Camino Drive, Suite 118
Scottsdale, Arizona 85258
Attn: Rick Tayrien

**Planning/Civil Engineering
Consultant**

CVL Consultants, Inc.

4550 North 12th Street
Phoenix, Arizona 85014
Attn: Julie Vermillion
602-285-4765

Contents

1. Introduction	1
2. Project History	2
3. Request	3
4. Description of Proposal.	3
5. Open Space	4
6. Recreational Amenities	6
7. Pedestrian Circulation	6
8. Fences, Walls and Screening	6
9. Landscape Theme	7
10. Development Standards.	8
11. Land Use Data Summary	9
12. Housing Product	10
13. Signage	10
14. Location and Accessibility	10
15. Legal Description	11
16. Timing/Phasing of Development	11
17. Conformance to Adopted Land Use Plans	12
18. Existing Conditions.	12
Surrounding Properties	13
19. Utilities and Services	14
Water and Wastewater.	15
School District	15
20. Circulation.	16
21. Drainage	17
22. Conclusion	17

Exhibits

Vicinity Map	Exhibit A
Aerial Map	Exhibit B
Context Map	Exhibit C
Existing General Plan	Exhibit D
Existing Zoning Plan	Exhibit E
Proposed Zoning Plan	Exhibit F
Existing Site Plan	Exhibit G
Proposed Site Plan	Exhibit H
Phasing Plan	Exhibit I
Open Space and Amenities Plan	Exhibit J
Wall and Signage Plan	Exhibit K
Secondary Entry and Wall Elevations.	Exhibit L
Circulation Plan	Exhibit M
Streetscape Sections	Exhibit N
Primary Entry Elevation	Exhibit O
Major Entry Plan	Exhibit P
Main Park Conceptual Landscape Plan.	Exhibit Q
Legal Description with Exhibit	Exhibit R

Appendices

Retail Market Analysis	Appendix A
----------------------------------	------------

1. Introduction

CVL Consultants, Inc. (CVL) on behalf of and in conjunction with the property owner, LGI Homes – Arizona, LLC (LGI), is proceeding with a Planned Area Development (PAD) Amendment for development of Venida (the Project). Venida is an approximately 158.25-acre master planned community located at the southeast corner of Papago Road and Green Road in Pinal County, Arizona (the County). (Exhibit A, Vicinity Map).

The existing Venida PAD (case PZ-PD-023-06) was approved in 2006 and intended for future development by an end user that was yet to be determined. Larger lot sizes and a 15-acre commercial corner were planned for the community as a desirable land use for development at the time. Now, approximately 15 years later, there is a need to revise the land plan to reflect present-day conditions by bringing the design up to recent County standards and meeting current market demands to facilitate development of this long undeveloped property. The area is over-planned for Commercial as verified by our Retail Market Analysis, dated March 17, 2022 and included as Appendix A. It concludes that there is an oversupply of approximately 815.80 acres based on the demand for additional local serving retail land over the next 35 years and the available retail space and land within the primary market area.

The updated design proposed with this PAD amendment represents project visioning conducted by the homebuilder, LGI, who are taking on the Project with the objective of creating a new and attractive residential community. This vision extends to the sense of arrival and traffic calming experienced upon entering the community by way of landscaped roundabouts featured at each end of the internal collector road, which enhance the street pattern and add to the curvilinear roadway design. Opportunities are provided for added landscaping with significant landscape buffers wrapping around the perimeter of the Project and a comprehensive trail system, linking individual parcels and small community parks to a centrally located 4.5-acre Main Park with amenities, for connectivity throughout the overall Venida community.

The primary request of this PAD amendment is to update the existing Venida PAD in an effort to provide an attractive overall land use and lot size that meets the desires of current and future homebuyers while updating the design to meet current Pinal County design standards. Specifically, a modification to the land plan is required to address the updated right-of-way width on Green Road, to incorporate a substantial open space buffer ranging from 80' to 212' in width along the eastern property boundary to incorporate the drainage solution, to adjust the approved land use and lot mix for the flexibility to permit a mix of 45' and 55' wide lots throughout, and to establish an Open Space Recreation Plan (OSRP) to promote the County's

initiative for increased open space requirements and standards within master planned communities.

With the Project's location at an arterial intersection in a rapidly growing area of Pinal County, the proposed mix of 45' x 120' and 55' x 120' lots are well suited for the neighborhood and will help create opportunities for more affordable detached single-family housing while remaining in compliance with the approved density of 3.50 dwelling units per acre (du/ac) designated by Pinal County's Comprehensive Plan. The Project will maintain the design character of the existing approved Venida PAD through its landscaping theme, walls and amenities.

Residents will have ample opportunity for active and passive recreation with significant open space provided throughout the Project, including small community parks within the majority of parcels and a centrally located 4.5-acre Main Park featuring amenities for all ages within a walkable distance for residents. The provided open space and pedestrian circulation plans, further described in Section 5 of this proposal, highlight the thoughtful consideration of open space corridors and trail connectivity, while promoting a clear focus on separating pedestrian and vehicular routes for efficient and safe traffic circulation.

With the approval of this PAD amendment, the Project will be developed as indicated on Exhibit H, Proposed Site Plan, and further described in this proposal. A comparison of the existing approved site plan and proposed revisions are illustrated on Exhibits G and H. The design concept and street pattern for the original residential portion of the Project is maintained with the current layout. The design updates described in this proposal are consistent with or improve upon the overall development standards, open space, landscape theme and intent of the existing Venida PAD.

2. Project History

The existing Venida PAD was approved in 2006 under case PZ-PD-023-06. The overall master planned community consists of approximately 143.50 acres of single family residential use zoned as CR-3 Single Residence with one CB-2 General Business parcel containing 15 acres intended for future commercial use at the southeast corner of Papago Road and Green Road. The Venida PAD was planned for a minimum of 15% open space, approximately 21.53 acres, and a density of 3.50 du/ac for the overall Venida community, in accordance with the Moderate Low Density Residential (MLDR) land use designation established by the County's Comprehensive Plan. The Venida community remains unplatted and undeveloped at this point in time.

3. Request

To accomplish the Venida community as intended, the request is as follows:

- Amend the lotting for the Project, including the lot mix; open space; density; and unit counts, as indicated on the proposed site plan provided as Exhibit H.
- Remove the 15-acre commercial area from the plan, increasing the residential area from 143.50 acres to 158.25 acres.

This request removes the commercial area, increasing the residential area from 143.50 acres to 158.25 acres and the maximum permitted yield by approximately 52 lots, while remaining in compliance with Pinal County’s Comprehensive Plan designation for the Project, Moderate Low Density Residential (MLDR) at 3.50 du/ac. This request increases the total open space of the Project from the previous 15% minimum required by the existing Venida PAD to 18% minimum to meet the current County standards. A Tentative Plat for the Project is currently in progress to be submitted under separate application.

4. Description of Proposal

As stated previously, nearly 15 years has passed since the initial approval of the Venida PAD and there is an imperative need to bring the original design up to current Pinal County standards and adapt to the significant change in the housing market. The Project is proposing an update to the existing approved lot mix in order to facilitate development of the site while satisfying the current market demand for smaller lot sizes and opportunities for affordable housing options.

The existing approved and proposed lot mix for the Project are provided in the table below for comparison:

Lot Mix		
	Approved	Proposed
45' x 120'	-	± 388 lots
48' x 115'	220 lots	-
55' x 120'	-	± 156 lots
58' x 115'	190 lots	-
68' x 120'	92 lots	-
Total *	502 lots	± 544 lots

Note: *An overall density of 3.50 du/ac is permitted for a maximum lot count of 554 lots. Final lot counts, density, and individual parcel data are subject to change and will be determined during the Tentative Plat and Final Plat processes.

As established in the preceding table, the number of smaller lots increased and typical lot sizes of 45' x 120' and 55' x 120' were introduced while the larger lot sizes were removed from the design. Portions of the lotting design have been adjusted as a result of these modifications to the lot mix but the general street pattern for this residential portion of the community remains unchanged. The design updates have a minor impact and maintain consistency with the established design intent of the Venida community.

The Project consists of single family lots with typical lot sizes of 45' x 120' and 55' x 120'. The requested 45' and 55' wide lot sizes are better suited to meet market demand and attract future homebuyers than the outdated larger lots currently in place. In addition, with the street pattern featuring design elements such as knuckles, cul-de-sacs, and curvilinear roads at various points, irregular lots ranging in size from 5,200 square feet up to around 13,872 square feet are featured throughout the community. Nearly half of the 45' x 120' lots identified on the Proposed Site Plan exceed the standard lot size and feature increased width, depth, pie shaped lots, or otherwise irregular lot sizes containing a lot area greater than the typical 5,400 square feet.

All development standards, residential permitted uses and the residential zoning district set by the existing approved Venida PAD remain unchanged as summarized below in Sections 10 and 11.

The vehicular access, circulation and infrastructure set by the existing approved Venida PAD generally remain unchanged apart from the updates required to meet current day Pinal County standards. The design is summarized below in Section 21.

The intent of the signage, open space plan and landscape theme established by the existing Venida PAD is maintained as detailed below in Sections 5-9 and 13. The locations and alignments of trails, amenities and open space areas have shifted slightly due to lotting revisions but the intent, quality and number of trails and amenities meet or exceed the original approval.

5. Open Space

Venida shall have a minimum of 18% of developed open space distributed throughout each of the parcels with recreation open space as defined within the PAD ordinance. The single-family residential lots within Venida shall benefit from accessible, dedicated recreational open space, centrally located in the community per County requirements for residents' equitable proximity.

Proposed amenity areas shall meet the “Family” level of recreation as designated by the County, including at minimum a pathway in addition to sidewalk and an additional one acre of turf field, a play area (minimum 60 feet in diameter) and/or picnic ramada (minimum 16’ x 16’) where possible. Individual amenities are proposed to give further character to each of the central recreation areas, such as picnic areas, multi-use fields, gardens, or passive play games such as cornhole or bocce. Other open space areas within the proposed community will include concrete sidewalks, offering connectivity to the various central open spaces, and additional amenities as illustrated on the Open Space and Amenities Plan provided as Exhibit J and the Main Park Conceptual Landscape Plan provided as Exhibit Q.

The 15% minimum open space required for the overall Venida PAD is updated to 18% minimum for the Venida community to comply with current Pinal County standards. The required existing and proposed open space is detailed in the table provided below

Open Space				
	Approved		Proposed	
Required	21.53 acres	15% min.	28.48 acres	18% min.

The site has less than 5% slope and the entire site is considered disturbed land due to its agricultural history. Due to these conditions, the open space requirements for disturbed conservation open space requires 0 acres of conservation open space for the community. A minimum of 18% (28.48 acres) is proposed for developed open space, comprising landscape tracts, streetscape frontage, and recreational area open space. Of the required 18% developed open space, 7% (11.10 acres) is required for recreational area open space. The minimum open space requirements are outlined in the following table:

Category (for 0-5% slope)	Area Required	Area Provided
Conservation Open Space	0 acres	0 acres (all disturbed - farm)
Developed Open Space	18% (28.48 ac)	28.48 acres (18%)
Recreation Open Space	7% (11.10 acre)	11.10 acres (7%)
Total Open Space¹	28.48 acres	28.48 acres

¹“Total Open Space” is the combination of conservation and developed open space. Developed open space includes recreation open space.

The ownership, control and maintenance of landscaping, open space and recreation facilities will be conveyed to and held in common by homeowners association(s) (HOA). All open space areas, landscaping and recreation facilities shall be maintained so that their use and enjoyment as elements of the Venida community are not diminished or destroyed. Please refer to the Open Space and Recreation Plan provided for detailed information.

6. Recreational Amenities

The single-family residential lots within Venida shall benefit from accessible, dedicated recreational open space, centrally located in the community per County requirements for residents' equitable proximity. The proposed development exceeds the minimum standards with multiple play structure areas and large group picnic ramadas at the large, centrally located Main Park. Small group ramadas, various activities and additional turf are provided throughout the open space areas and small community parks placed around the Project. In addition, seating nodes with tree shade are provided along the paths and trails throughout the community to provide pleasant and comfortable outdoor enjoyment. Pathways connect the amenities to nearby sidewalks for ease of access within and between parcels. The amenity areas are illustrated on the Open Space and Amenities Plan provided as Exhibit J and the Main Park Conceptual Landscape Plan provided as Exhibit Q.

7. Pedestrian Circulation

Pedestrian circulation within Venida will be provided by sidewalks and open space pathways. Circulation along the local streets will occur on sidewalks adjacent to the curb. Connections to the open space areas from these attached sidewalks will be provided by pathways that meander through the open space tracts. All paved access routes shall meet ADA guidelines. The central location of open space will not only allow for efficient access for residents but will also allow for pedestrian access from many of the proposed home sites without needing to cross a major roadway.

8. Fences, Walls and Screening

Venida will be an integrated part of the surrounding community. Proposed wall types shall provide a visually pleasing sense of community character, providing a cohesive uniformity across the parcels while maximizing open views and an interesting patterning of wall color and texture. The design character, including walls, entry monuments, and amenities will be based on the design established by the existing plans approved for the Venida community in 2006. The materials have been refined to be lower maintenance while still maintaining the established 2006 aesthetic.

Project signage will be provided in optimal locations at entries for ease of way-finding. A thematic monument with ground signage will be provided at the Papago Road entry, and a secondary monument will be located at the Green Road entry, with additional signage. Wall and sign locations and elevations have been illustrated in detail on the following exhibits: Wall and Signage Plan (Exhibit K), the Primary Entry Elevations (Exhibit O) and Secondary Entry and Wall Elevations (Exhibit L).

9. Landscape Theme

The Venida project will combine the principles of open space landscaping with the functions of storm drainage and retention to create an efficient and attractive design. The plants for the developed open space and streetscape will be selected to create an appropriate landscape palette, drawing from the property's former agrarian usage while meeting ADWR low-water use criteria. Larger-canopy trees shall be planted with the intent to shade sidewalks and provide comfort for pedestrians. Distinct theme trees will be proposed to provide character in the central amenity areas and entries. The overall planting style will be naturalized, with trees clustered at focal points and access points.

The plant palette and planting design has been developed in conformance to the Open Space and Recreation Area Guideline Manual (OSRAM). Groundcover shall be balanced in quantity with trees and shrubs. Trees, shrubs and groundcovers shall be planted in naturalized clusters and provide color in variation with the seasons. Meandering landscape tracts along street frontages shall be planted in conformance with these design standards and clustering of accent and theme trees will further enhance the variety and focal areas along streetscapes and open space tracts. All plants used will be from the ADWR low water use list for Pinal County. Final planting design will conform to the densities established in the OSRAM.

Larger-canopy trees shall be planted with the intent to shade sidewalks and provide comfort for pedestrians, with emphasis on providing shaded western and southern exposures. Where space allows, trees over 30' feet will be used to provide shade and low maintenance shrubs will be specified in hard to access areas. Distinct theme trees will be proposed to provide character in the central amenity areas and entries. Native plants have been specified and will be prioritized where appropriate across the site. As discussed with town reviewer, turf quantities have been minimized and large expanses will be covered with a mix of decomposed granite, native seed mix, and shrubs.

All landscaping shall be consistent with the Pinal County codes, ordinances rules and guidelines. Prior to development on the property, the area will be maintained in a natural, debris and weed-free condition.

10. Development Standards

The development standards remain primarily as approved with the Venida PAD (PZ-PD-023-06), apart from an update to incorporate the newly designated R-7 development standards and a slight decrease in minimum lot area to account for typical impacts to lot area on lots located on corners, knuckles, and cul-de-sacs. The table below illustrates the proposed development standards for Venida set forth by this amendment:

R-7 PAD		
	Code	Proposed
Min. Lot Area	7,000 sq. ft.	5,150 sq. ft.
Min. Lot Width	50'	45'
Min. Front Yard Setback	20'	20'*/10'*
Min. Side Yard Setback	10'	5'
Min. Rear Yard Setback	25'	15'
Max. Building Height	30'	30'
Detached Accessory Buildings		
Max. Permitted Coverage	33% of the total area of the rear and side setbacks	33% of the total area of the rear and side setbacks
Max. Height	20'	20'
Min. Distance to Main Building	7'	5'
Min. Distance to Front Lot Line	60'	60'
Min. Distance to Side and Rear Lot Lines	4'	4'

Note:* 20' from face of garage to back of sidewalk (approximately 15' to property line) and 10' to livable or side entry garage.

11. Land Use Data Summary

Proposed Site Plan (Exhibit H)

	Existing	Proposed
Gross Area	158.50 acres	158.25 acres
Net Area*	143.50 acres	158.25 acres
Commercial Area	15.00 acres	0.00 acres
Residential Area	143.50 acres	158.25 acres
Assessors Parcel #s	510520020 & 510520030	510520020 & 510520030
Zoning	CR-3/PAD & CB-1/PAD	R-7/PAD
Number of Lots	502 lots	± 544 lots <i>(up to 554 lots permitted)</i>
Density**	3.50 du/ac	± 3.44 du/ac <i>(up to 3.50 du/ac permitted)</i>
Open Space Required	21.53 acres / 15%	28.48 acres / 18%

Note: *Net Area = Gross Area - Commercial
 **Density = Number of Lots / Net Area

Zoning District	Phase	Parcel	Lot Size	Number of Lots	Gross Area (AC)	Density (DU/AC)
R-7/PAD	1	1	45' x 120'	± 88	± 29.94	± 2.93
		2	55' x 120'	± 82	± 26.39	± 3.01
		3	45' x 120'	± 71	± 23.11	± 3.19
		4	45' x 120'	± 61	± 22.34	± 2.57
	2	5	45' x 120'	± 68	± 14.23	± 4.75
		6	45' x 120'	± 100	± 19.75	± 5.33
		7	55' x 120'	± 74	± 22.49	± 3.38
Total *				± 544	± 158.25	± 3.44

*An overall density of 3.50 du/ac is permitted for a maximum lot count of 554 lots. Final lot counts, density, and individual parcel data are subject to change and will be determined during the Tentative Plat and Final Plat processes.

As established in the preceding table, this request removes the commercial area, increasing the residential area from 143.50 acres to 158.25 acres and the maximum permitted yield by approximately 52 lots, while remaining in compliance with Pinal County’s Comprehensive Plan designation for the Project, Moderate Low Density Residential (MLDR) at 3.50 du/ac.

While the proposed design currently falls below the previously approved density, this amendment maintains the maximum permitted density of 3.50 du/ac approved by the existing Venida PAD and the Pinal County Comprehensive Plan .

12. Housing Product

Venida's design concept responds to the existing and future needs of the community by providing an attractive housing option for future homebuyers seeking to live in this area. Careful attention will be given to the proposed house plans to ensure compatibility with the surrounding neighborhood and the County's standards for architectural quality. Residents will have their choice of available product elevations, floor plans and color palette options.

The single-family homes will include plans that provide attractive materials and architectural features. The architectural house styles will comply with the standards set forth in this PAD document and will be compatible with the surrounding development. Architectural elevations, floor plans and color schemes will be submitted for approval through Pinal County's building review process.

13. Signage

As approved in the existing Venida PAD, signage for the Project shall meet Pinal County ordinances, codes and guidelines. Project signage will be provided in optimal locations at entries for ease of way-finding. A thematic monument with ground signage will be provided at the Papago Road entry and at the southernmost entry. Wall and sign locations and elevations have been illustrated in detail on the attached exhibits. Signage shall be in accordance with the Pinal County Zoning Ordinance.

14. Location and Accessibility

The proposed Venida development lies southwest of the intersection of Papago Road and Green Road in Pinal County, Arizona. Specifically the Project is a portion of land located in the Northwest Quarter of Section 21 in Township 5 South, Range 3 East of the Gila and Salt River Meridian, Pinal County, Arizona. The Maricopa (Ak-Chin) Reservation is located within one mile of the property and the City of Maricopa is located approximately 3 miles to the north of the site.

Regionally, the following highways provide access to surrounding communities.

- Maricopa - Casa Grande Highway: Venida is approximately 4 miles southwest of the Maricopa-Casa Grande Highway, which provides direct access to the City of Casa Grande located southeast of the community.
- Interstate 10: Venida is approximately 6 miles south of interchange via John Wayne Parkway and Papago Road, which creates a direct route from the Venida community to the interstate, and in turn allows regional links to metro Phoenix and further outlying communities.
- Interstate 8: Venida is approximately 7 miles north of this interstate.

The Property is accessed from Papago Road to the north and from Green Road to the west, with two collector roadways proposed along the southern and eastern boundaries of the Project.

There are no Regionally Significant Routes (RSR) abutting the Project according to Pinal County’s Regionally Significant Routes for Safety and Mobility (RSRSM) plan.

15. Legal Description

Venida is a portion of land located in the Northwest Quarter of Section 21 in Township 5 South, Range 3 East of the Gila and Salt River Meridian, Pinal County, Arizona. A Legal Description and associated Map (Exhibit R) are provided to define the boundaries of the Project.

16. Timing/Phasing of Development

The Project consists of single-family residential parcels and infrastructure roads planned to be built in two phases. Phase 1 will include Parcels 1-4. Phase 2 will include Parcels 5-7. Half street improvements to Papago Road, Green Road, and the collector roadways provided along the southern and eastern boundaries of the Project will be constructed within Phase 1 of the Project.

All common areas and open space amenities will be developed along with the parcel they are located in. Utilities and infrastructure will connect to all parcels through the development of the internal collector road centrally located within the Project. A phasing plan is attached as Exhibit I.

Phasing Schedule (Exhibit I)

Phasing - Site Data			
	Phase 1	Phase 2	Overall
Gross Area	± 4,433,348 sq. ft. / ± 101.78 acres	± 2,459,810 sq. ft. / ± 56.47 acres	6,893,158 sq. ft. / 158.25 acres
Net Area*	± 4,433,348 sq. ft. / ± 101.78 acres	± 2,459,810 sq. ft. / ± 56.47 acres	6,893,158 sq. ft. / 158.25 acres
Number of Lots	± 302 lots	± 242 lots	± 544 lots
Density**	± 2.97 du/ac	± 4.29 du/ac	± 3.44 du/ac

Note: *Net Area = Gross Area - Commercial

**Density = Number of Lots / Net Area

Phasing - Infrastructure and Amenities	
Phase 1	Phase 2
<ul style="list-style-type: none"> • Papago Road, Green Road, interior streets, perimeter collector roadways, and internal collector roadway. • Primary entries (2) • Additional access points (2) • Main park • Small community parks (2) • Planted open space areas with pathways • Planted open space areas 	<ul style="list-style-type: none"> • Interior streets • Secondary entries (2) • Small community park • Garden walk • Picnic area • Planted open space areas with pathways • Planted open space areas

17. Conformance to Adopted Land Use Plans

The current Pinal County Comprehensive Plan designates the Project’s land use as Moderate Low Density Residential (MLDR) with an allowable density range of 1 to 3.50 du/ac. The current density for the site plan intended for the Project is approximately 3.44 du/ac with a maximum permitted density of 3.50 du/ac, which is consistent with and conforms to the Comprehensive Plan. The surrounding area adjacent to the community is also designated as MLDR.

Venida has been designed in a manner that is consistent with the development standards, circulation, character, and density approved by the existing Venida PAD and intends to further the implementation of and not be contrary to the goals, policies and applicable elements of the approved PAD and Pinal County Comprehensive Plan.

18. Existing Conditions

The Project is bordered on the north by Papago Road, on the south and east by agricultural fields and on the west by Green Road. Specifically, the Project is located within the Northwest Quarter of Section 21 in Township 5 South, Range 3 East of the Gila and Salt River Meridian, Pinal County, Arizona. The property is rectangular in shape and consists of approximately 160 acres of agricultural fields. The site slopes from the southwest to the northeast at approximately 0.3%.

Surrounding Properties

Although there is a substantial amount of undeveloped land surrounding the Project, this proposal complements those communities planned in the area. The properties surrounding the Project are as follows:

Direction	Use	Zoning	General Plan
North	Undeveloped agricultural land.	GR	Moderate Low Density Residential
South	Undeveloped agricultural land.	GR	Moderate Low Density Residential
East	Undeveloped agricultural land.	GR	Moderate Low Density Residential
West	Undeveloped agricultural land planned for Tresana, a master planned community.	CR-3/PAD & CB-2/PAD	Moderate Low Density Residential

The Project is composed of residential lots connected by an integrated network of open space and recreation facilities as further described within this proposal. The proposed community is an appropriate land use for the Project that will complement the significant growth planned in this area of Pinal County. The master planned communities in the immediate surrounding area are as follows:

Community	Direction	Zoning	General Plan
Amarillo Creek	North of the Project to the west of Green Road.	CR-3/PAD & CB-2/PAD	Moderate Low Density Residential
Tresana	Directly west of the Project.	CR-3/PAD & CB-2/PAD	Moderate Low Density Residential
Sunset Canyon	Approximately 1/2 of a mile directly south of the Project on Green Road.	CR-3/PAD	Moderate Low Density Residential
Pecan Woods	Approximately 1/2 of a mile directly west of the Project on Papago Road.	CR-3/PAD	Moderate Low Density Residential

A context map is provided as Exhibit C and illustrates detailed information on the adjacent zoning, trails, and street alignments available within the surrounding area.

19. Utilities and Services

All proposed utility systems and plans will be accessed and designed per Pinal County standards and submitted for staff review and approval with the Tentative and Final Plat processes. The following utilities and services have been analyzed and/or researched to determine their existing facilities, their adequacy, and their capacity in relation to the Project:

Service	Provider	Phone #	Adequacy-Status Statement
Sewer	Global Water	866-940-1102	Existing community capacities and facilities are being analyzed to determine the capability for servicing the proposed project. Proposed on-site and off-site improvements to be designed and constructed per County standards.
Water	Global Water	866-940-1102	Existing community capacities and facilities are being analyzed to determine the capability for servicing the proposed project. Proposed on-site and off-site improvements to be designed and constructed per County standards.
Service	Provider	Phone #	Adequacy-Status Statement
Electric	Arizona Public Service	602-371-7171	Existing community facilities to be determined adequate for servicing the proposed project. Proposed on-site and off-site improvements to be designed and constructed by APS.
Telephone	Century Link / Cox Communications	602-630-5480 / 623-328-3807	Existing community facilities to be determined adequate for servicing the proposed project. Proposed on-site and off-site improvements to be designed and constructed by provider.
Gas	Southwest Gas	877-860-6020	Existing community facilities to be determined adequate for servicing the proposed project. Proposed on-site and off-site improvements to be designed and constructed by provider.
Police	Pinal County Sheriff's Office	1-800-420-8689	Existing community services to be determined adequate for servicing the proposed project.
Fire	South Maricopa Facilities Association	520-723-4680	Existing community services to be extended to include the proposed project. A new fire station is proposed on a parcel directly west of the Project and south of Papago Road.
Schools	Maricopa Unified School District	520-568-5100	The Maricopa Unified School District was notified of the project via first-class mail. Correspondence with the school district will be provided to County staff.
Solid Waste	Private Hauler	480-983-9101	Existing community services to be extended to include the proposed project.

Note: Additional coordination with the above providers is necessary to confirm adequate servicing.

Water and Wastewater

The Project is within the Certificate of Convenience and Necessity (“CCN”) of Global Water Resources (GWR). GWR water and wastewater systems exist in the area and are proposed to serve the development with required infrastructure improvements.

The water service connections will be made to the existing Global Water – Maricopa Water Company water system within Papago Road and Green Road. A proposed off site waterline will need to be constructed and connected from the intersection of Green Road and Papago Road to the onsite connection to serve Venida. Global Water will connect the proposed onsite system of 8-inch waterlines to the proposed waterline within Green Road and another connection will be made to the existing 12-inch waterline within Papago Road.

The wastewater system for Venida will be owned and operated by GWR. The sewer infrastructure shall conform to GWR Design and Construction Standards for Potable Water, Recycled Water and Wastewater Infrastructure, dated January 2017. The proposed onsite sewer system will flow by gravity into an existing 30-inch and 42-inch offsite sewer within Papago Road. Please refer to the Preliminary Water and Wastewater Master Plans for additional information.

School District

The Venida community is completely within the Maricopa Unified School District which has schools within 7 to 8 miles of the Project. Saddleback Elementary School, Maricopa Wells Middle School and Maricopa High School are located to the north of the community in the City of Maricopa. The Maricopa Unified School District was notified of the proposed PAD amendment via first-class mail. Correspondence and associated responses from the school district will be submitted to the County.

Additional neighborhoods, parks, community centers, and retail are readily available nearby within the City of Maricopa located to the north of the Project.

20. Circulation

As approved by the existing Venida PAD, internal circulation to the community will be provided by entrances constructed from Papago Road to the north, Green Road to the west and collector roadways along the southern and eastern boundaries. The site access locations meet the Pinal County requirements for driveway spacing. An internal collector road bisects the community along a curvilinear north-south alignment to provide access to each neighborhood within Venida.

Streets and thoroughfares are proposed with the suitability and adequacy to serve the proposed uses and the anticipated traffic has been accommodated through the use of appropriately designed streets. Roundabouts, T-intersections, knuckles and curvilinear streets have been designed in order to slow traffic and add interest throughout the community. The proposed small community parks, 4.5-acre Main Park, and trail system will be easily accessible from the collectors or neighborhood streets.

Two round-a-bouts with landscaped medians are provided along the internal collector road near the entrances from Papago Road to the north and the east-west collector road along the southern boundary, as a thoughtful design element to provide residents with a sense of arrival into the community and additional traffic calming along the curvilinear roadway. The design highlights efficient and safe traffic circulation with careful consideration of open space corridors and trail connectivity, while promoting a clear focus on separating pedestrian and vehicular circulation where possible throughout the community.

Half street improvements are planned along the boundary off site roadways. The half street cross sections include Papago Road and Green Road as arterial roadways featuring 55 feet and 75 feet of right of way, respectively. The collector roadways provided along the southern and eastern boundaries of the Project are designed as major collector roadways with half street improvements planned for 40 feet of right of way. The primary collector road within the Project is planned as a major collector roadway with 80 feet of right of way. All streets are to be built per Pinal County Standards. Please refer to the Traffic Impact Analysis for additional information.

21. Drainage

The Pinal County, Arizona and Incorporated Areas Flood Insurance Rate Map (FIRM), Map Number 04021C1125E, Map Revised December 4, 2007, indicates the subject site falls within Zone X.

Zone X is defined by FEMA as: “Areas of 0.2% annual chance flood; areas of 1% annual chance flood with average depths of less than 1 foot or with drainage areas less than 1 square mile; and areas protected by levees from 1% annual chance flood.”

The Project consists of approximately 160 acres of agricultural fields and slopes from the southwest to the northeast at approximately 0.3%. The property contains moderate vegetation and is not located within any part of a regulated floodplain. No natural washes exceeding 200 CFS were observed within the project that would require conservation. The community will be designed to meet the Pinal County design requirements using the Pinal County Drainage Manuals (PCDM) Volume I, Design Criteria, Volume II, Design Methodology and Procedures, and the Pinal County Drainage Ordinance. Please refer to the Master Drainage Report for additional information.

22. Conclusion

The above-mentioned design updates for the Venida community uphold the intent of the existing land use designated for the area while activating this undeveloped property for new and attractive residential development. This request provides compatibility with existing development in the area while supporting the goals and objectives of Pinal County. The proposed PAD amendment makes good land use sense on this property, maintains compatibility with the surrounding neighborhood, and will be an attractive presence in the area.

As described above, there is a need to revise the land plan to reflect present-day conditions by bringing the design up to current County standards and meeting current market demands to facilitate development of this long undeveloped property. With the proposed updates, this community is poised to enhance the existing surrounding community and extend and complete the area’s infrastructure.

The development team believes that this request represents appropriate and favorable planning for the Venida community. We look forward to working with County staff in the processing of this project.

Vicinity Map

Exhibit A

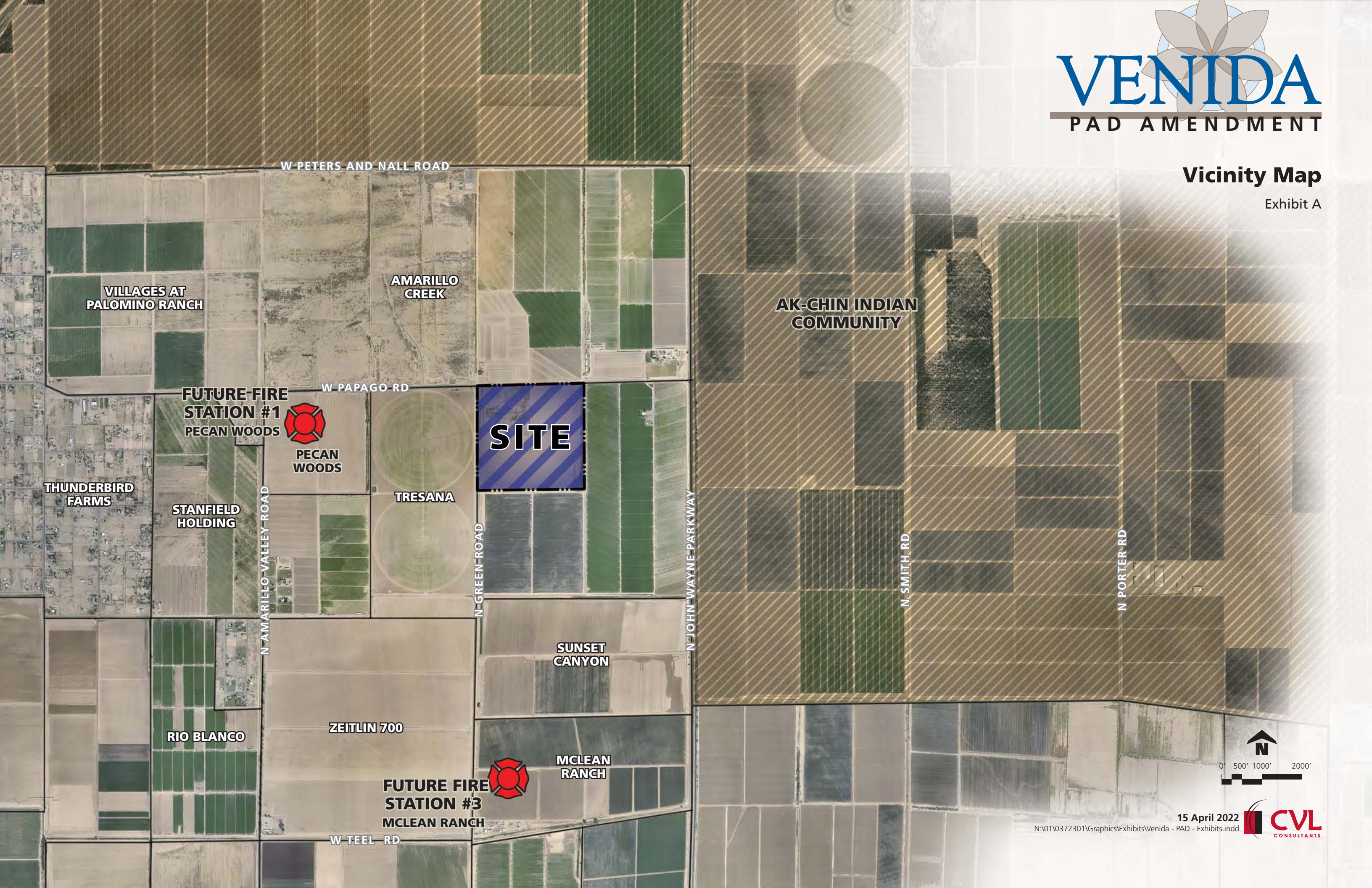



VENIDA

PAD AMENDMENT

Aerial Map

Exhibit B

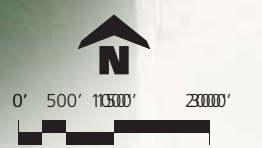

15 April 2022

N:\01\0372301\Graphics\Exhibits\Venida - PAD - Exhibits.indd



VENIDA









PAD AMENDMENT

Context Map

Existing Zoning

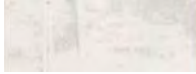
Exhibit C.1

LEGEND
Pinal County Zoning



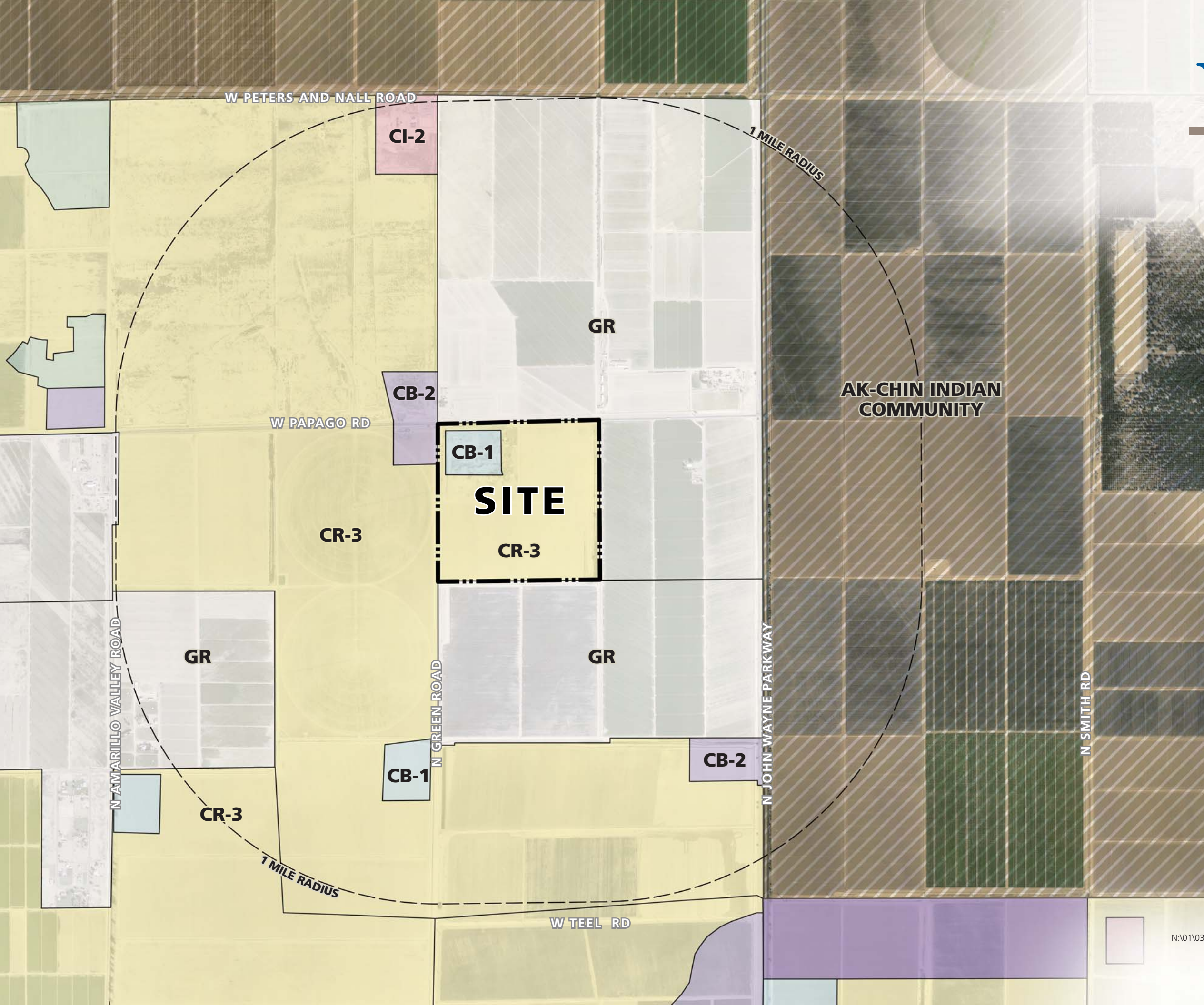







	CB-1
	CB-2
	CI-2
	CR-3
	GR General Rural
	Ak-Chin Indian Community
	Project Boundary
	1 Mile Radius



Context Map Connectivity

Exhibit C.2

LEGEND



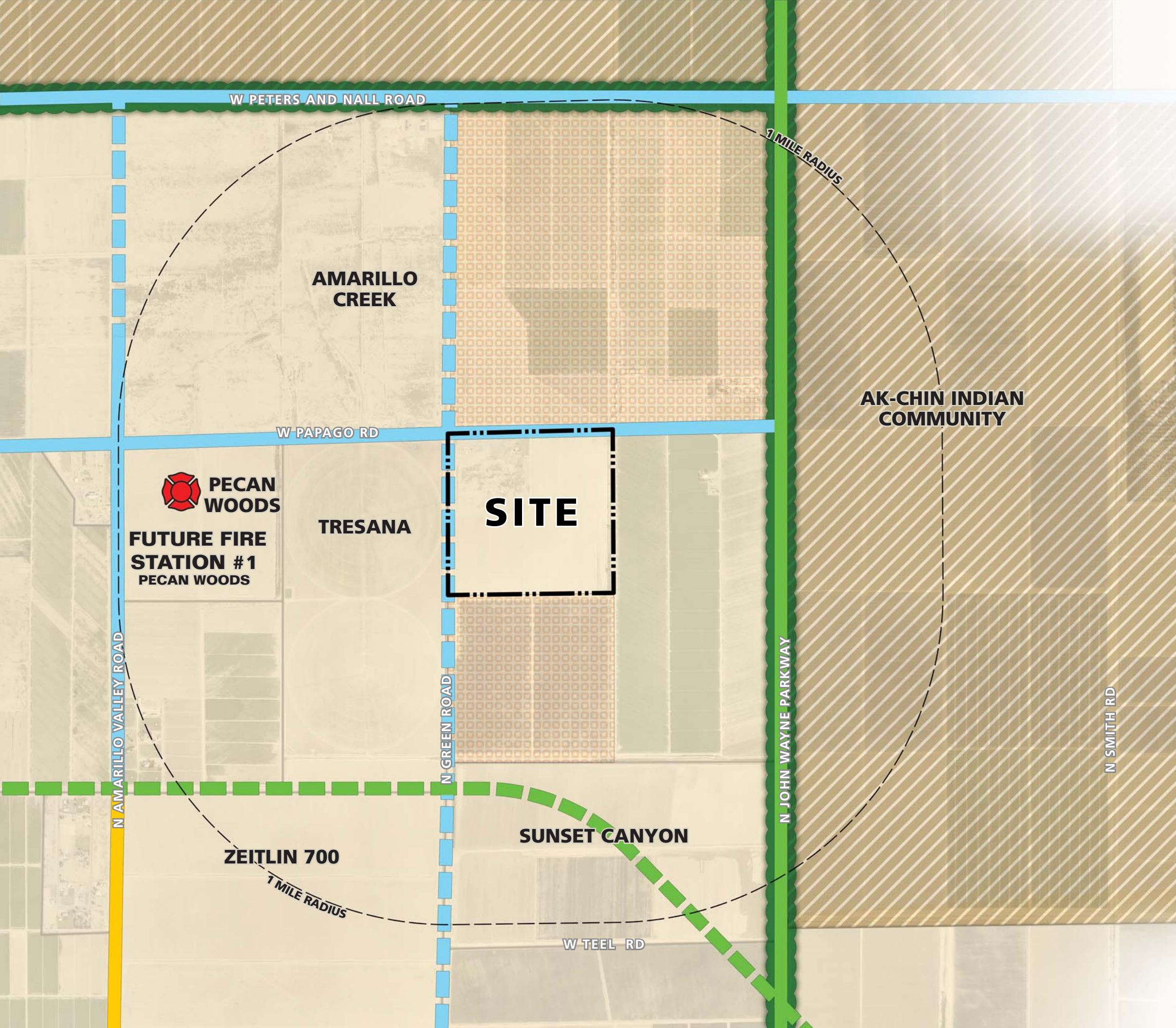

-  Parkway
-  Future Parkway
-  Principal Arterial
-  Minor Arterial
-  Minor Arterial (Unpaved)
-  Pinal County Existing/Planned Multi-use Trail Corridor
-  Ak-Chin Indian Community
-  State Land
-  Future Fire Station
-  Project Boundary
-  1 Mile Radius



Existing General Plan

Exhibit D

LEGEND
Pinal County Zoning

	Moderate Low Density Residential (1-3.5 du/ac)
	Employment
	Ak-Chin Indian Community
	Project Boundary
	1 Mile Radius

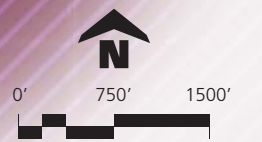
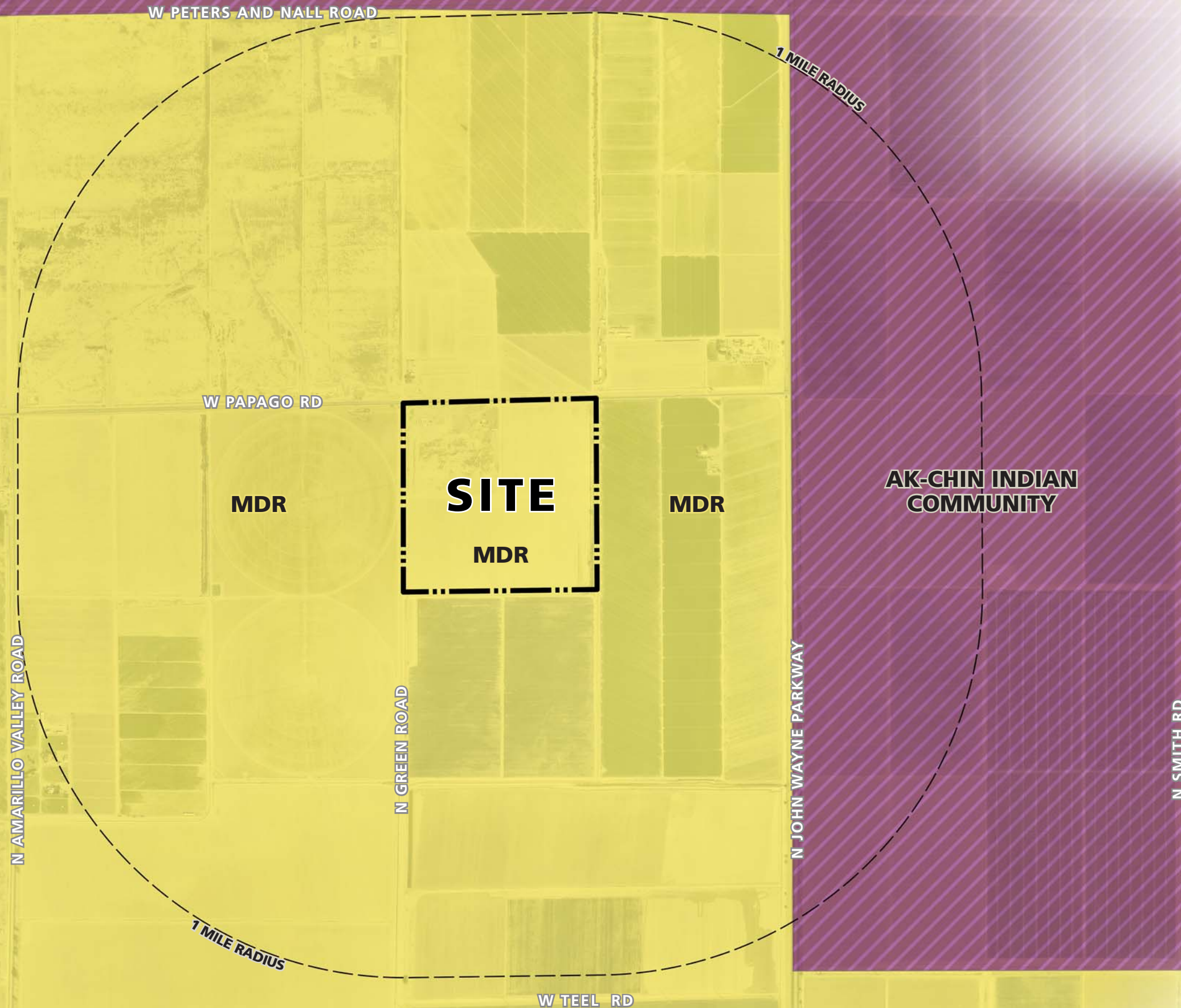

Existing Zoning Plan

Exhibit E

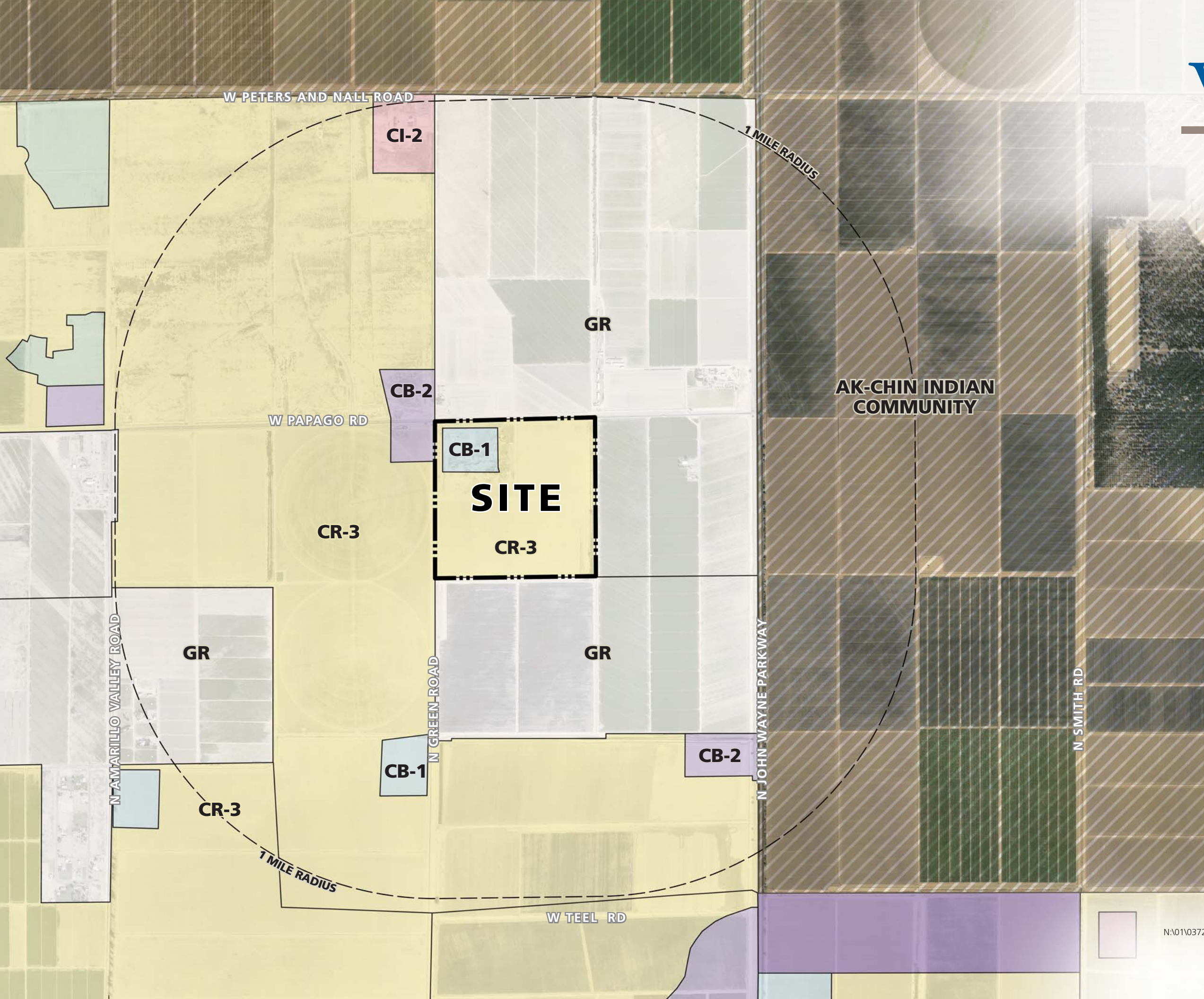

LEGEND

Pinal County Zoning

	CB-1
	CB-2
	CI-2
	CR-3
	GR General Rural
	Ak-Chin Indian Community
	Project Boundary
	1 Mile Radius



15 April 2022







N:\01\0372301\Graphics\Exhibits\Venida - PAD - Exhibits.indd



Proposed Zoning Plan

Exhibit F

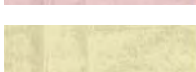
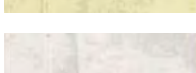
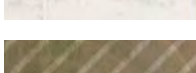
LEGEND
Pinal County Zoning

	R-7
	CB-1
	CB-2
	CI-2
	CR-3
	GR General Rural
	Ak-Chin Indian Community
	Project Boundary
	1 Mile Radius

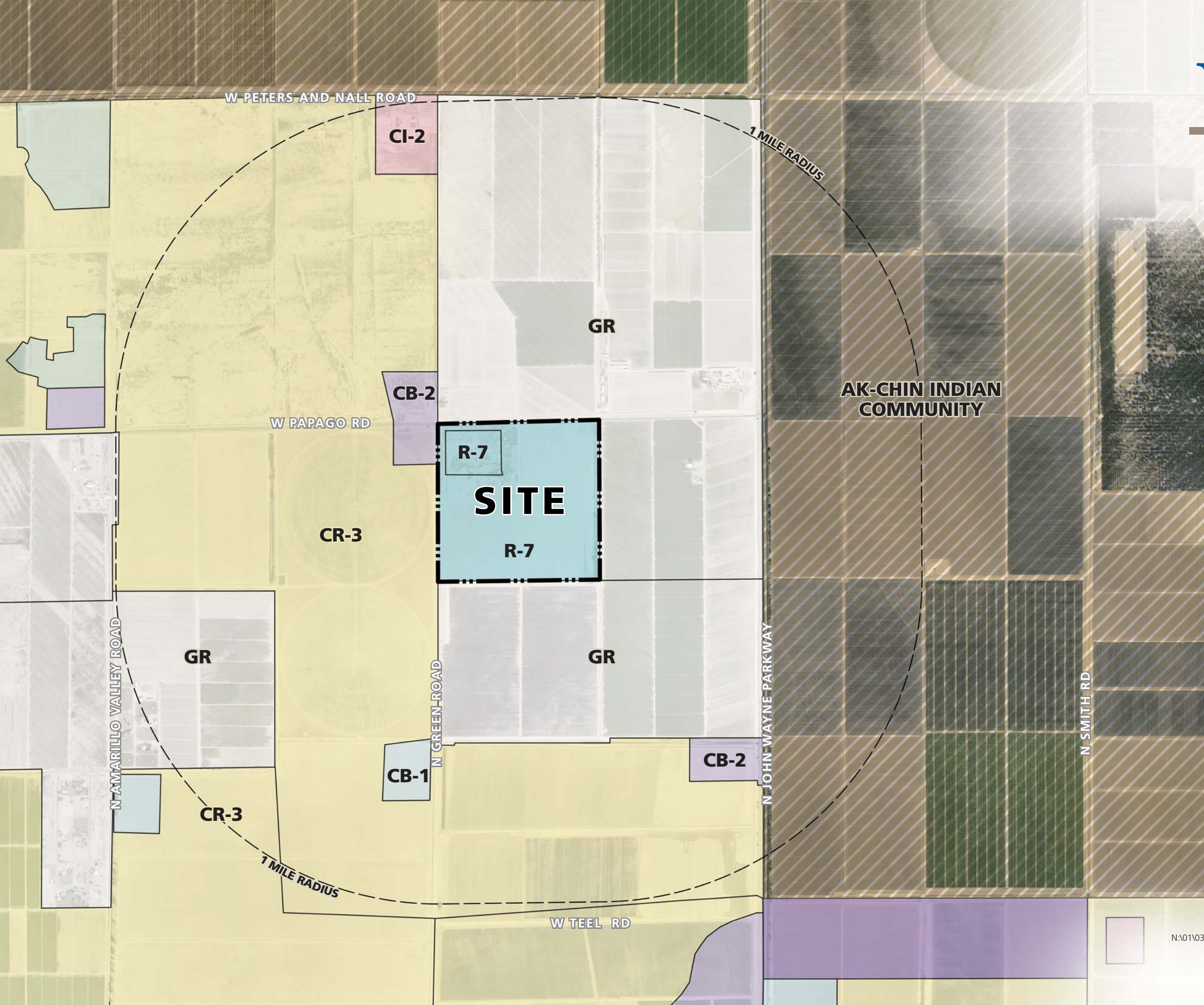

Existing Site Plan

Exhibit G

Use	Area
Single Family	104.8 AC
Commercial	15.0
Open Space	21.5
Roads	17.2
Total	158.5 AC

Density = 3.5 Du/AC
 Residential Area = 143.5 AC
 Dwelling Units = 502

Open Space (15% Residential Area)
 Required 143.5 @ 15% = 21.5 AC
 Provided 21.5 AC

Legend

-  Single Family Residential (48' Lots)
-  Single Family Residential (58' Lots)
-  Single Family Residential (68' Lots)
-  Commercial
-  Open Space
-  Trails

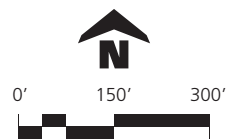

SITE COMPARISON				
Site Data	Existing Plan		Proposed Plan	
Gross Area	158.50 acres		158.25 acres	
Commercial Area	15.00 acres		0.00 acres	
Residential Area	143.50 acres		158.25 acres	
Zoning	CR-3/PAD & CB-1/PAD		R-7/PAD	
Max. Density Permitted	3.50 du/ac		3.50 du/ac	
Approximate Density Provided	3.50 du/ac		± 3.44 du/ac	
Open Space	21.53 acres	15%	± 28.48 acres	± 18%
Lot Mix	Existing Plan		Proposed Plan	
45' X 120'			± 388 lots	± 71%
48' X 115'	220 lots	44%		
55' X 120'			± 156 lots	± 29%
58' X 115'	190 lots	38%		
68' X 120'	92 lots	18%		
Total	502 lots	100%	± 544 lots	100%

Proposed Site Plan

Exhibit H



LEGEND

- 55' x 120'
- 45' x 120'
- Open Space
- Trails

SITE DATA		
Gross Area	158.25 acres	
Zoning	R-7/PAD	
Max. Density Permitted	3.50 du/ac	
Approximate Density Provided	± 3.44 du/ac	
Approximate Number of Lots	45' x 120'	± 388 lots
	55' x 120'	± 156 lots
	Total	± 544 lots
Open Space Required	± 28.48 acres	± 18%

SITE COMPARISON				
Site Data	Existing Plan		Proposed Plan	
Gross Area	158.50 acres		158.25 acres	
Commercial Area	15.00 acres		0.00 acres	
Residential Area	143.50 acres		158.25 acres	
Zoning	CR-3/PAD & CB-1/PAD		R-7/PAD	
Max. Density Permitted	3.50 du/ac		3.50 du/ac	
Approximate Density Provided	3.50 du/ac		± 3.44 du/ac	
Open Space Required	21.53 acres	15%	± 28.48 acres	± 18%
Lot Mix	Existing Plan		Proposed Plan	
45' X 120'			± 388 lots	± 71%
48' X 115'	220 lots	44%		
55' X 120'			± 156 lots	± 29%
58' X 115'	190 lots	38%		
68' X 120'	92 lots	18%		
Total	502 lots	100%	± 544 lots	100%

Note: Final lot counts, density, open space, and individual parcel data are subject to change and will be finalized during the Tentative Plat and Final Plat processes.



Phasing Plan

Exhibit I

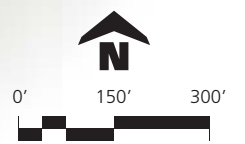
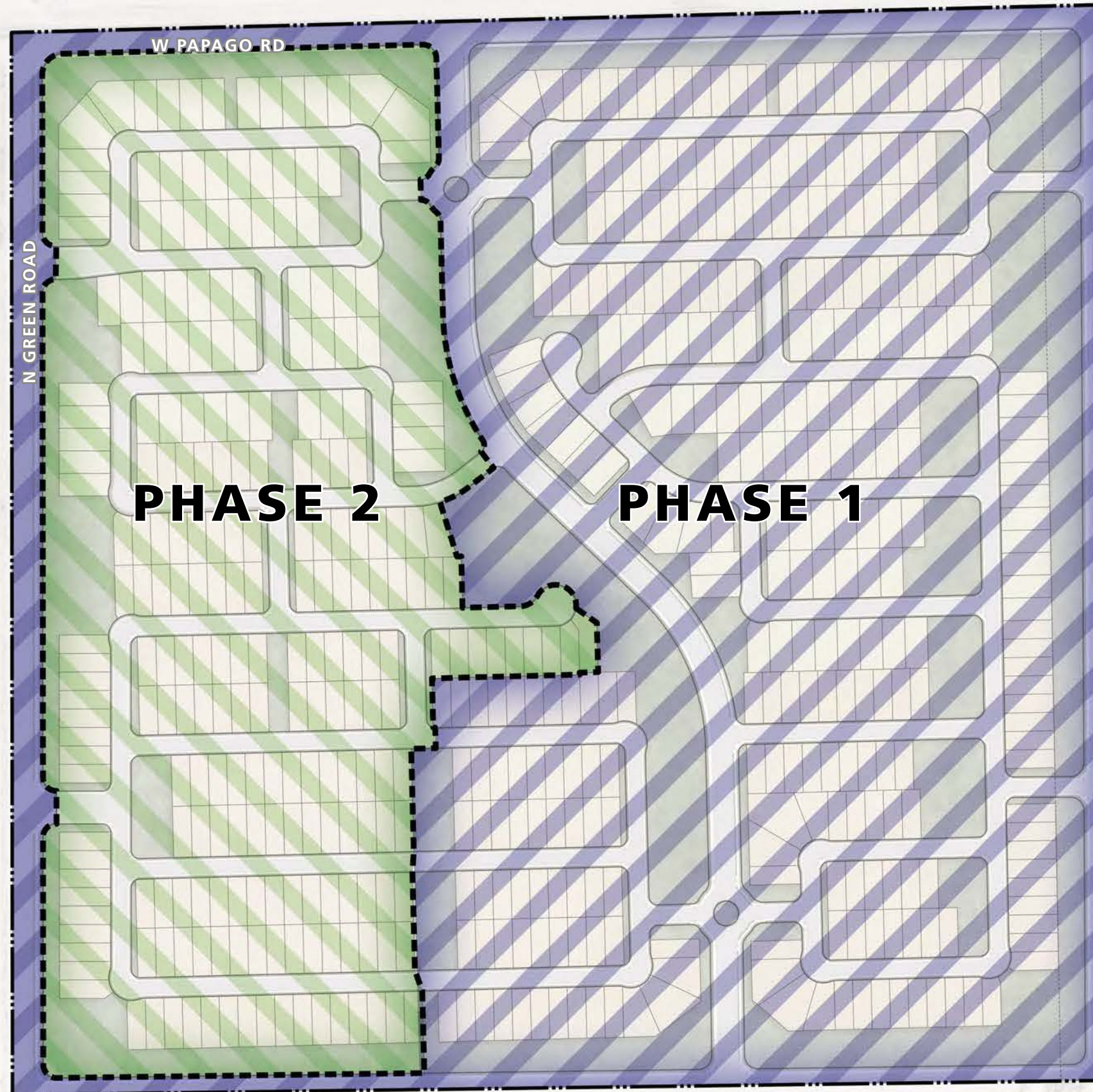

Open Space and Amenities Plan

Exhibit J

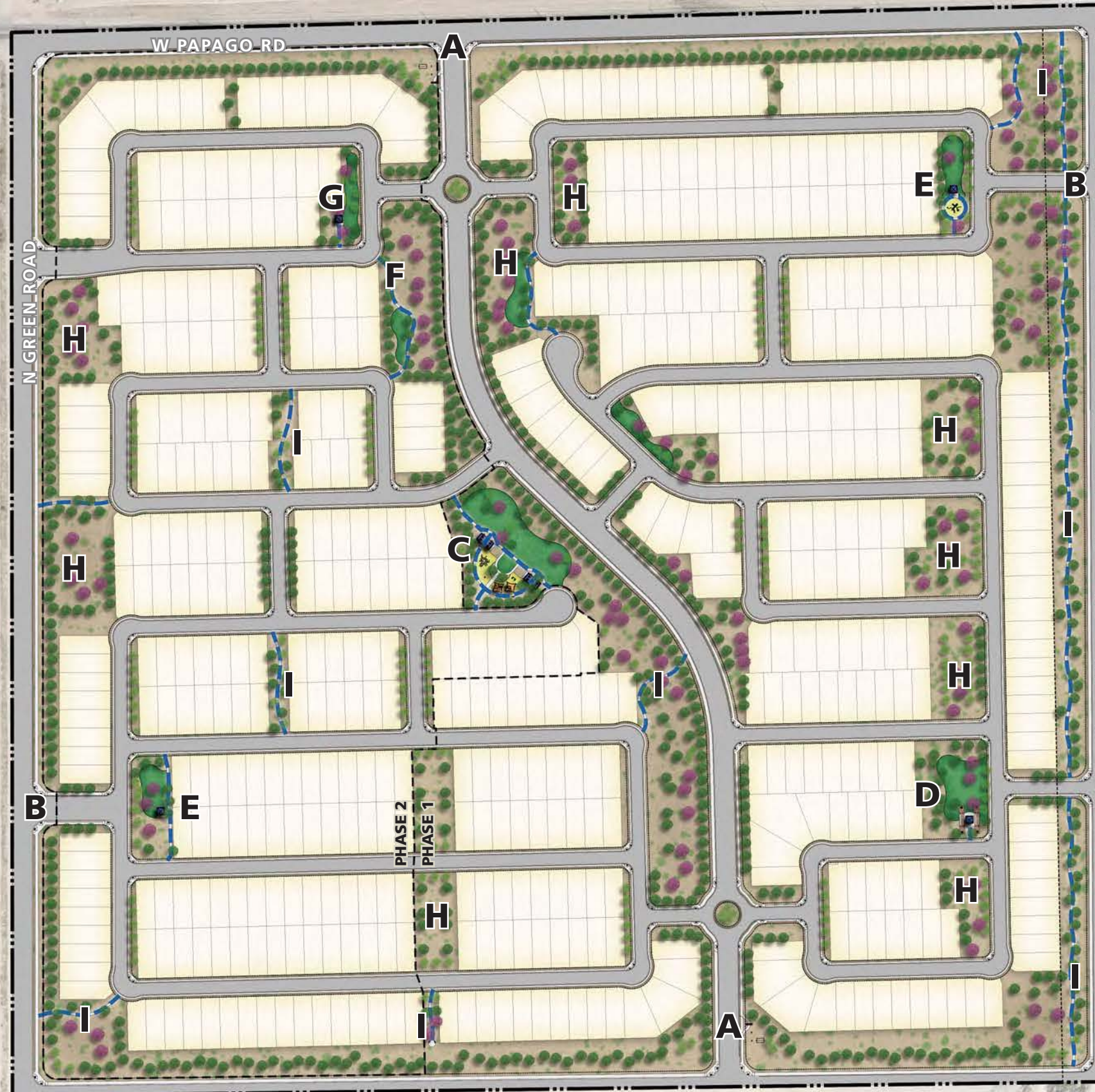

LEGEND

- A** Primary Entry Monument
- B** Secondary Entry Signage
- C** Main Park
 - Play Structure
 - Two Large Ramada / Picnic Areas
 - Multi-Use Fields
 - Lighting at Amenities
- D** Small Community Park
 - Corn Hole
 - Ramada / Picnic Area
- E** Small Community Park
 - Play Structure
 - Ramada / Picnic Area
- F** Garden Walk
 - Pollinator Garden
 - Hardscape and Benches
- G** Picnic Area
 - Pickleball
 - Ramada / Picnic Area
- H** Planted Open Space
- I** Planted Open Space with Pathway

15 April 2022





N:\01\0372301\Graphics\Exhibits\Venida - PAD - Exhibits.indd

Wall & Signage Plan

Exhibit K



LEGEND

-  Primary Entry Monument
-  Secondary Entry Accents
-  Theme Wall at Entry
-  Theme Wall
-  Secondary Wall

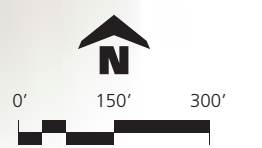

**Secondary Entry and
Wall Elevations**

Exhibit L

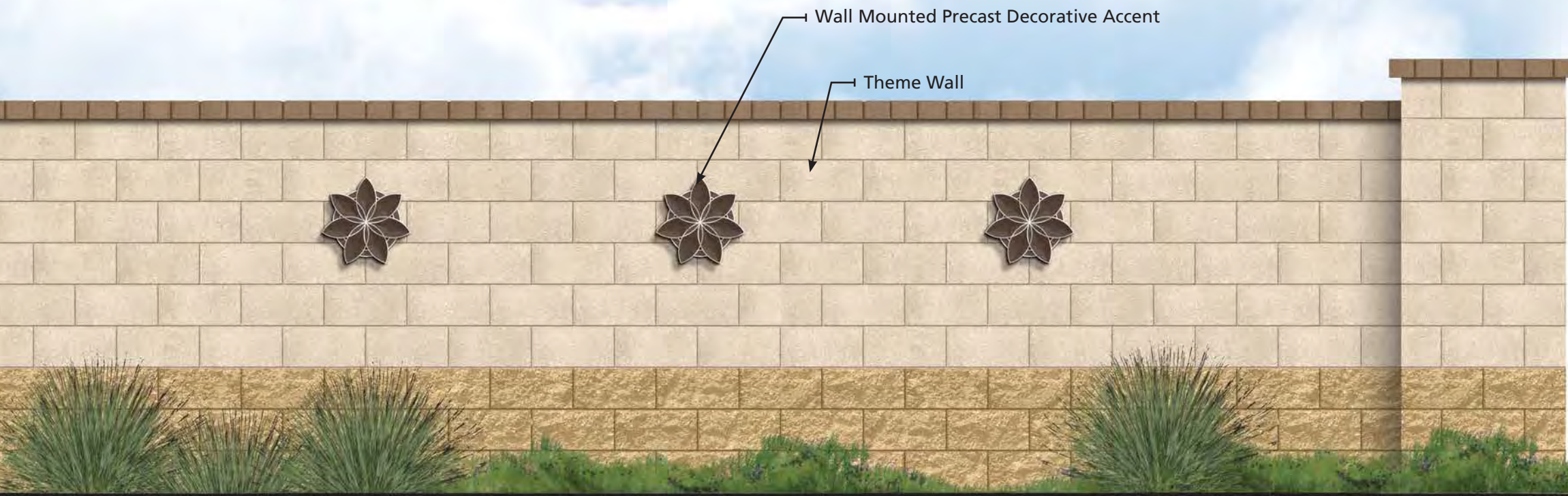

SECONDARY ENTRY ACCENTS

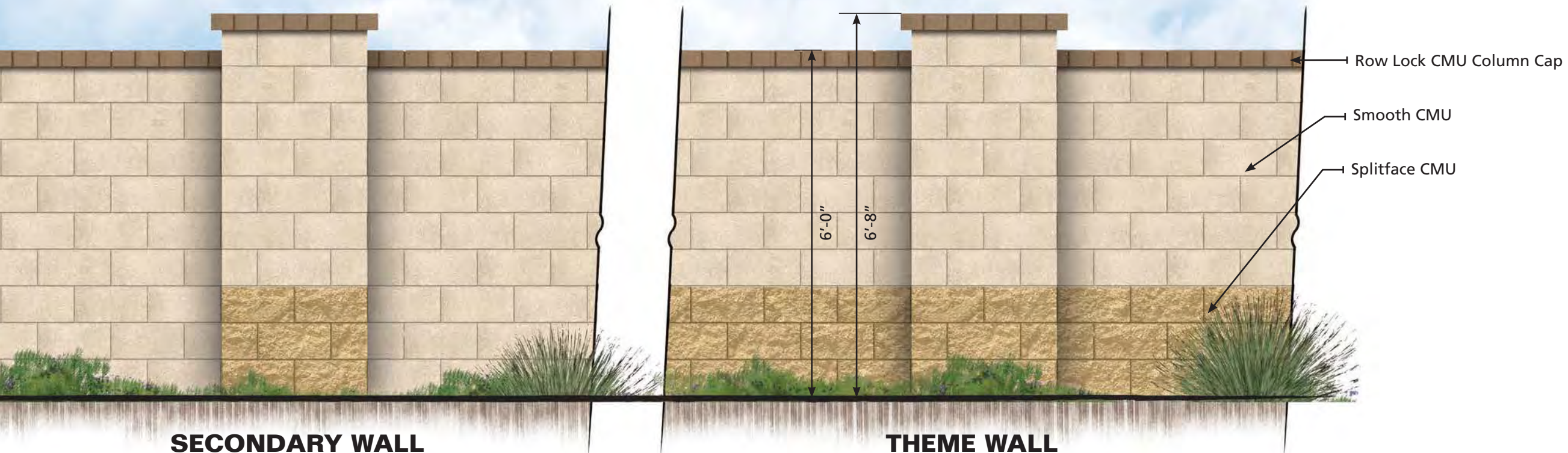

SECONDARY WALL



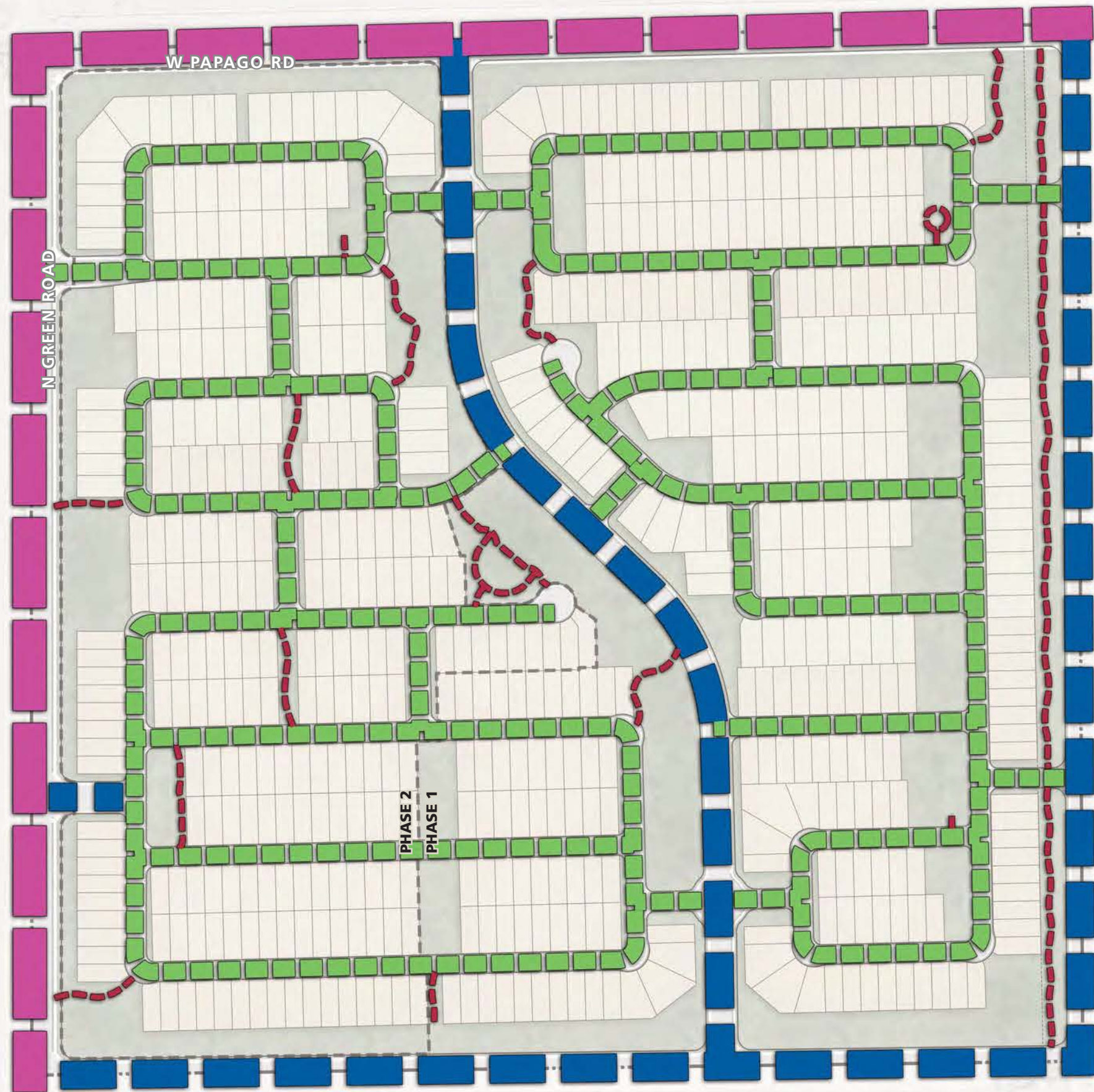

THEME WALL

Circulation Plan

Exhibit M



LEGEND

- | | | |
|---|--|--|
|  |  | Arterial |
| | | • 6.5' Bike Lane |
| | | • 8' Detached Sidewalk |
|  |  | Major Collector |
| | | • 8' Attached Sidewalk (West and North side) |
| | | • 6' Detached Sidewalk (East Side) |
|  |  | Local street |
| | | • 4' Attached Sidewalk |
|  | | Interior Trails |
| | | • 6' Paved |

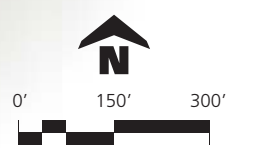

Streetscape Sections

Exhibit N

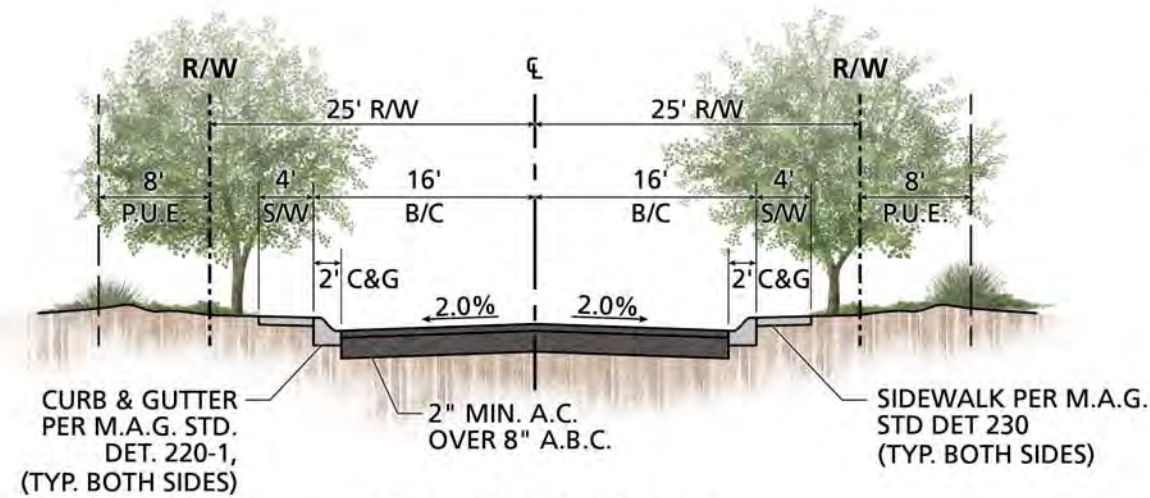

LOCAL STREET

N.T.S.

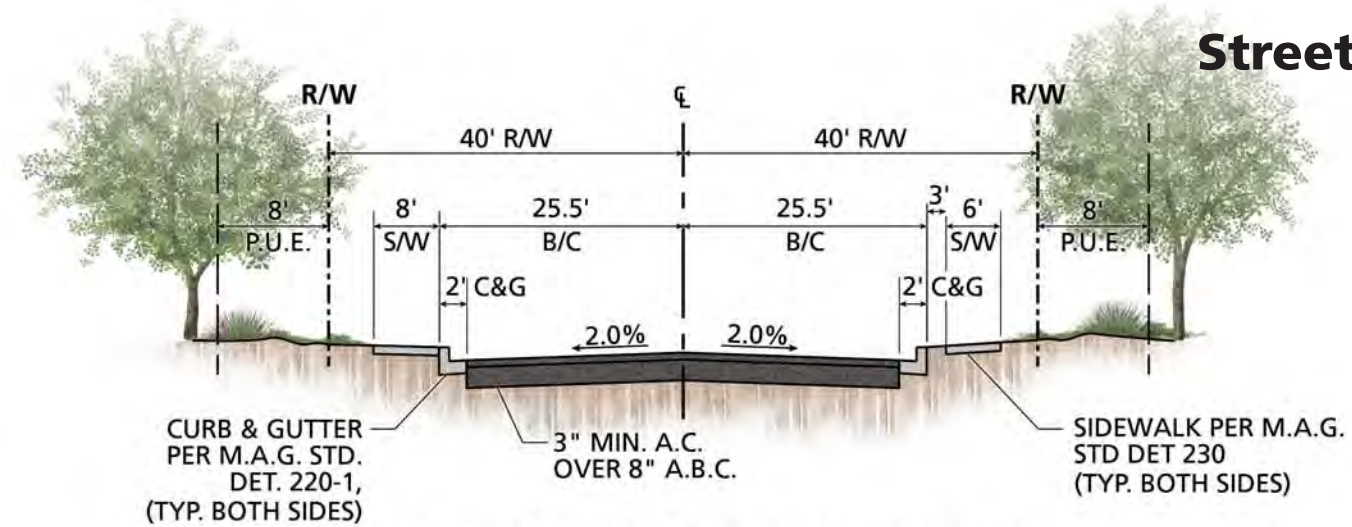

MAJOR COLLECTOR STREET

N.T.S.

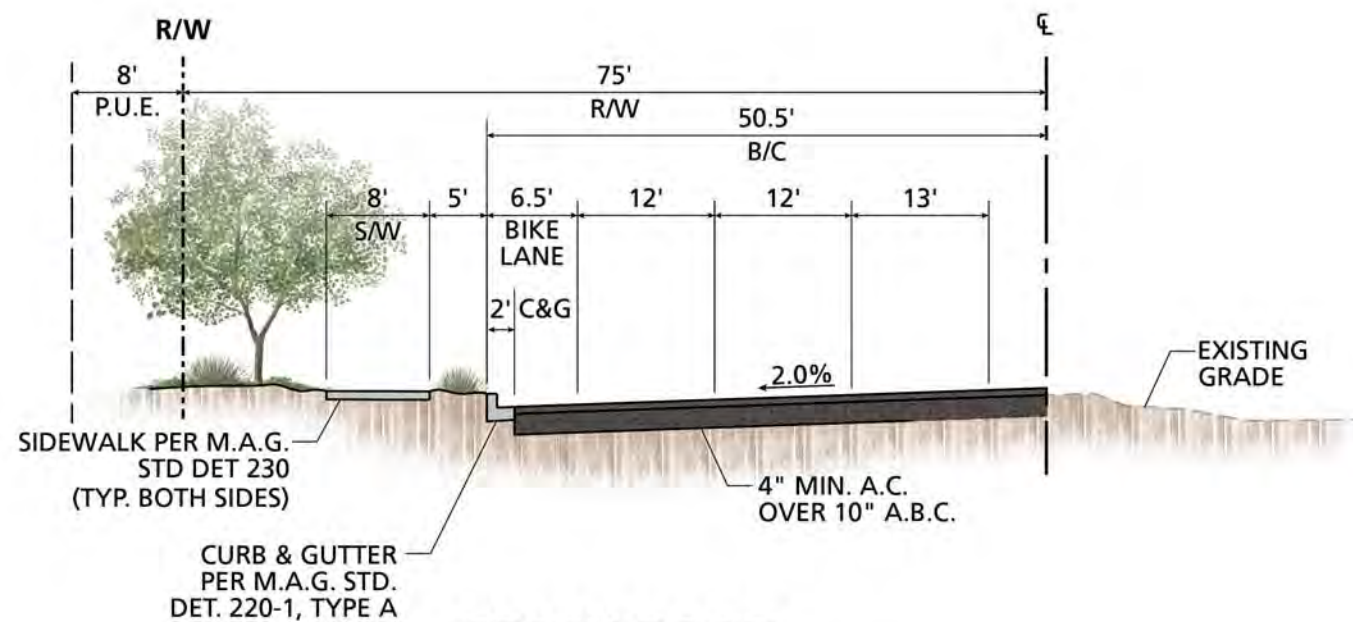

**GREEN ROAD
PROPOSED-LOOKING SOUTH**

N.T.S.

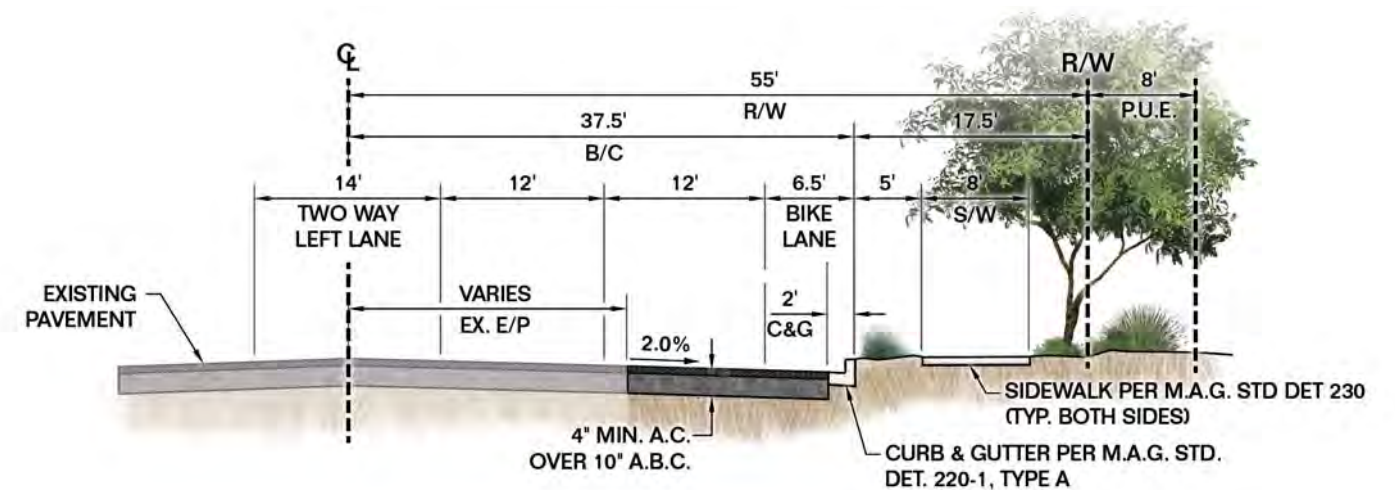

**PAPAGO ROAD
PROPOSED-LOOKING EAST**

N.T.S.

Primary Entry Elevation

Exhibit O



PRIMARY ENTRY MONUMENT ELEVATION

- Decorative Planter Set On CMU Plinth With Integral Irrigation
- Freestanding Stone Veneer Wall With Pin Mount Lettering
- Row Lock CMU Column Cap
- Raised Planter At Grade Smooth CMU
- Splitface CMU



ENTRY ACCENT WALL ELEVATION

Major Entry Plan

Exhibit P

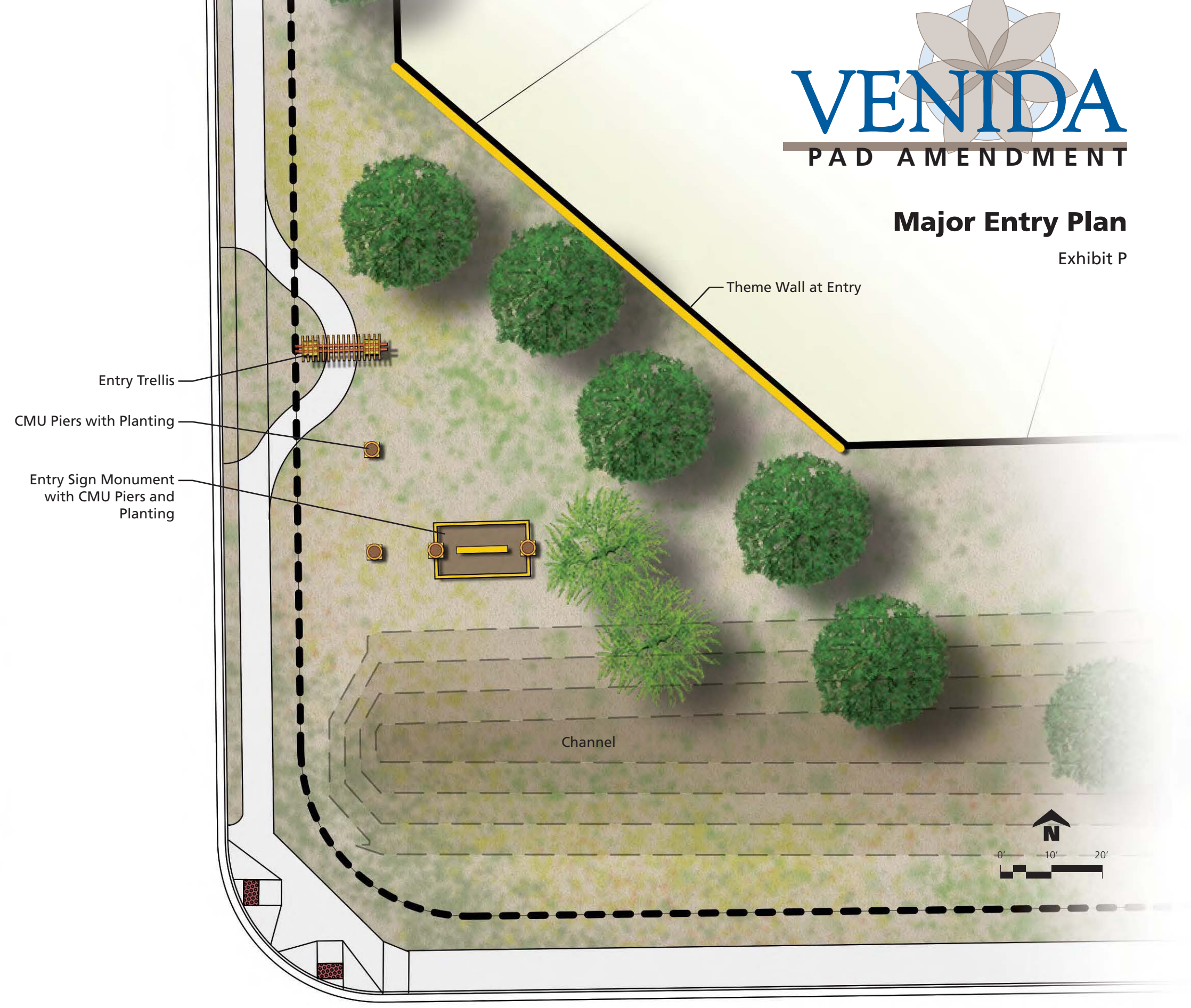
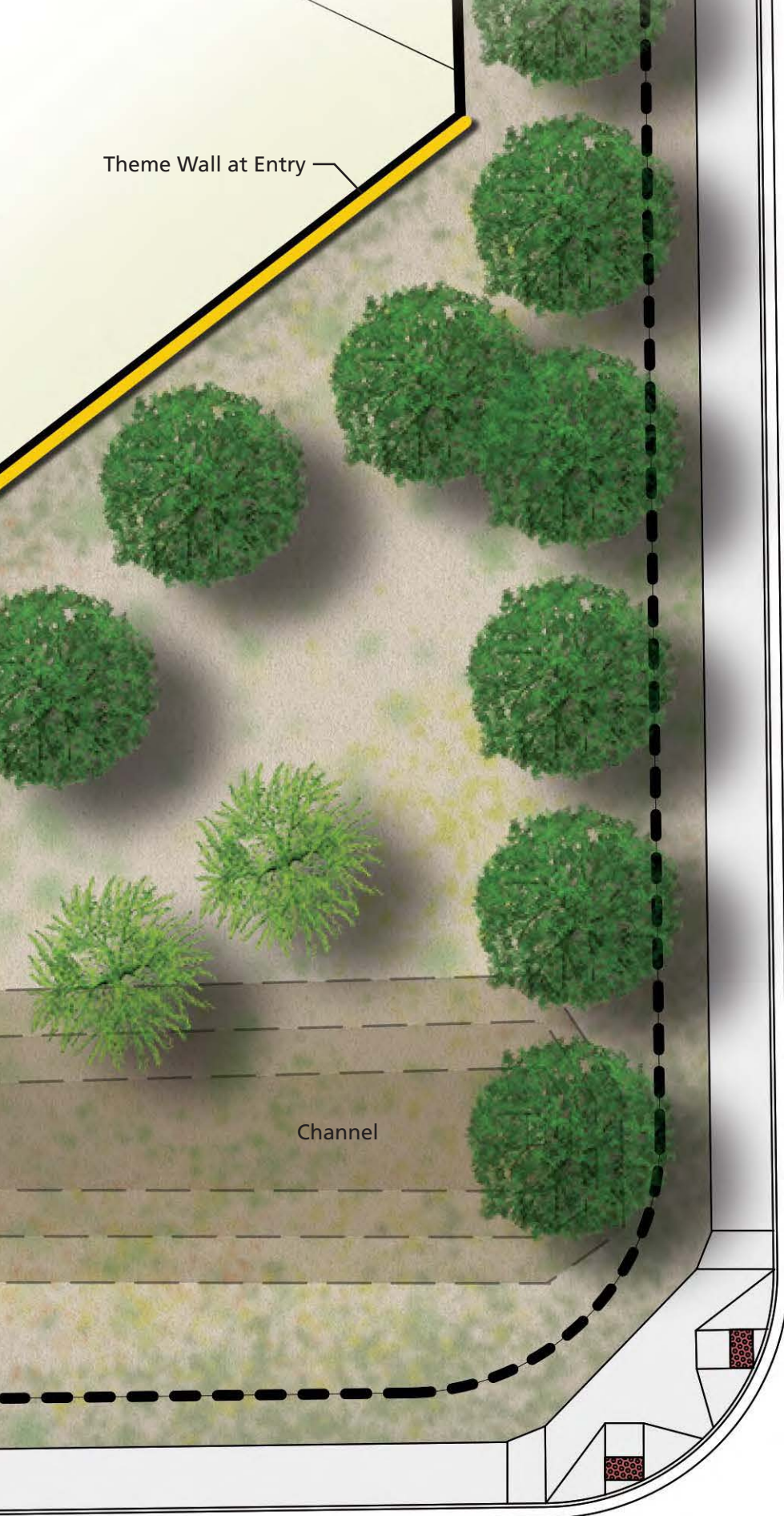

**Main Park
Conceptual
Landscape Plan**

Exhibit Q



LEGAL DESCRIPTION FOR
VENIDA
PROPERTY BOUNDARY

That part of the Northwest Quarter of Section 21, Township 5 South, Range 3 East, of the Gila and Salt River Meridian, Pinal County, Arizona, more particularly described as follows:

Beginning at the Northwest Corner of said Section 21;

Thence North 88°32'15" East, along the North line of the Northwest Quarter of said Section 21, a distance of 2,643.85 feet, to the North Quarter Corner of said Section 21;

Thence departing said North line, South 00°17'18" East, along the East line of said Northwest Quarter, a distance of 2,618.77 feet, to the Center of said Section 21;

Thence South 89°14'14" West, along the South line of said Northwest Quarter, a distance of 2,653.95 feet, to the West Quarter Corner of said Section 21;

Thence North 00°03'15" West, along the West line of said Northwest Quarter, a distance of 2,586.59 feet to the Point of Beginning.

Containing 6,893,158 Square Feet or 158.245 Acres, more or less.

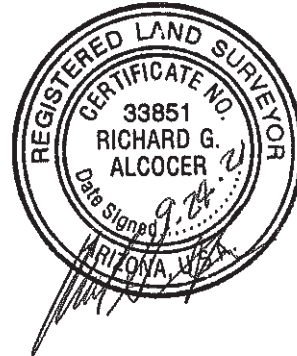

W. PAPAGO ROAD

NORTHEAST CORNER,
SECTION 21,
TOWNSHIP 5 SOUTH,
RANGE 3 EAST

N88°32'15"E 2643.85'

POINT OF BEGINNING
NORTHWEST CORNER,
SECTION 21, TOWNSHIP 5
SOUTH, RANGE 3 EAST

NORTH 1/4 CORNER,
SECTION 21,
TOWNSHIP 5 SOUTH,
RANGE 3 EAST

2643.62'
N88°31'55E

N. GREEN ROAD

N00°03'15"W 2586.59'

S00°17'18"E 2618.77'

APN 510-52-001A
PRATT, EDWARDS C TRUSTEE
FEE# 2017-004798

WEST QUARTER CORNER,
SECTION 21, TOWNSHIP 5
SOUTH, RANGE 3 EAST

CENTER OF,
SECTION 21,
TOWNSHIP 5 SOUTH,
RANGE 3 EAST

S89°14'14"W 2653.95'



APN 510-52-8030
PEARSON LARRY D



SCALE 1" = 500'

EXHIBIT

4550 North 12th Street
Phoenix, Arizona 85014
Phone 602-264-6831
<http://www.cvlci.com>

VENIDA

PROPERTY BOUNDARY



1 OF 1

CLOSURE REPORT
VENIDA
PROPERTY BOUNDARY

BOUNDARY

N88°32'14.6248" E 2,643.85

S00°17'17.7300" E 2,618.77

S89°14'14.1005" W 2,653.95

N00°03'15.1368" W 2,586.59

Area = 6,893,158 158.245 AC

Closing course: 276°40'43.3655" 0.007208

Misclosure: 1/1,000,000+

North Error: 0.000838

East Error: 0.007159

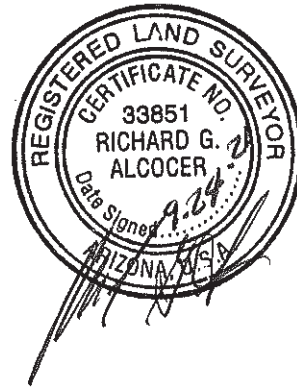

Retail Market Analysis

Papago Rd & Green Rd Primary Market Area

Pinal County, Arizona



Prepared for:

LGI

March 2022

DRAFT
3/17/2022

Prepared by:



Elliott D. Pollack & Company
7505 East 6th Avenue, Suite 100
Scottsdale, Arizona 85251

Table of Contents

Executive Summary	i
1.0 Purpose of Study	1
1.1 Report Outline	1
1.2 Limiting Conditions	1
2.0 Retail Market Overview	3
2.1 Impacts of E-Commerce	5
2.2 Impacts of Superstores and Warehouse Clubs	6
2.3 COVID-19 Impacts	7
2.4 Greater Phoenix Retail Market	8
2.5 Maricopa Retail Market	10
3.0 Market Area Overview	12
3.1 Market Area Description	12
3.2 Population and Households	14
3.3 Forecasts	16
3.4 Summary	24
4.0 Retail Supply & Demand Analysis	25
4.1 Market Area Retail Demand	25
4.2 Retail Forecast	29
4.3 Supply	30
4.4 Site Comparison	33
4.5 Summary	35
5.0 Conclusions & Recommendations	37



Executive Summary

Elliott D. Pollack & Company was retained to conduct an economic analysis of a proposed rezoning of a vacant 15-acre parcel located on the southeast corner of Papago Road and Green Road in Pinal County, Arizona (located south of the City of Maricopa and the Ak Chin Indian Community) from commercial to residential uses. The scope of this engagement is to evaluate the various economic and real estate aspects of the proposed change and its impact on future retail development.

Findings & Conclusions

The retail marketplace has been significantly impacted by recent business cycles, e-commerce, and the rise of supercenters and warehouse clubs. Retailers have become much more cautious planning for new stores. Some ten years after the end of the Great Recession, retail development has not come close to returning to prior construction levels. This trend is likely to continue for the foreseeable future, especially with the recent impacts of the COVID-19 pandemic and will impact properties currently designated for commercial development.

The Maricopa region is essentially at equilibrium in terms of what the current population can support. The need for additional households to support more local serving retail development will be a guiding factor for Maricopa and the surrounding Primary Market Area (PMA).

The latest forecast for population growth in the PMA concludes that demand for additional retail land will total an additional 670,300 square feet, or the equivalent of 96.2 acres over the next 35 years (through 2055). Forecasted retail demand is substantially lower than the estimated 6.8 million square feet of availability (combining 41,800 square feet of available space within existing centers and 912 acres of vacant commercial land). Potential commercial development within the Ak Chin Indian Community is also not included in the total.

Retail Supply/Demand Forecast				
Papago Rd & Green Rd 7-mile Radius				
	2030	2040	2055	35-Year Total
Household Growth	5,907	3,472	4,980	14,359
New Retail Demand (SF)	275,769	162,103	232,455	670,326
New Retail Demand (acres)	39.6	23.3	33.4	96.2
Supply (Available for Additional Retail Development)				
			Acres	SF
Existing Retail Centers				41,844
Vacant Land			912	6,738,100
TOTAL				6,779,944
Sources: MAG, 2019; U.S. Consumer Expenditure Survey; AZ DOR; Pinal County Assessor; City of Maricopa; Elliott D. Pollack & Company				



Compared to the available vacant space and available commercial land, there is far too much land in the Primary Market Area designated for future retail development. Even with more aggressive growth forecast scenarios, it is apparent that there is an oversupply of commercial land that is out of balance with future need. The area will never come close to needing the current amount of available commercial land.

Similar comments were recently echoed by the City of Maricopa. Based on their General Plan and the build out potential of population, City staff estimated that there is over twice the amount of available commercial land needed even after the City’s population nearly triples in size.¹

New retail development within the PMA is also occurring, most notably at John Wayne Parkway and Edison Avenue, totaling nearly 141,795 square feet. Development under construction includes a Sprout’s, Marshalls, Petco, and approximately 70,000 square feet of available shops and pads for restaurants, shops, and space for consumer services such as banking, medical, dental, and insurance. In addition, there are five other planned retail developments in the PMA which would create 251,000 square feet of space. In total, there is an estimated 392,800 square feet of commercial space either under construction or planned in the PMA. If all are built, these projects will fill the region’s retail needs for several years.

Retail Development Pipeline Papago Rd & Green Rd Primary Market Area				
Property Address	Property Name	Property Type	SF	Status
John Wayne Pky & Edison Ave	Sonoran Creek Marketplace	Community Center	102,072	Under Construction
18893 W Honeycutt Rd		Retail	19,723	Under Construction
44460 W Edison Rd		Retail	20,000	Under Renovation
41650 W Maricopa Casa Grande Hwy	The Wells	Retail	100,000	Proposed
SEC Hwy 347 & Edison St		Retail	2,500	Proposed
44500 W Edison Rd	Maricopa Marketplace II	Neighborhood Center	33,000	Proposed
NEC John Wayne Pky & Honeycutt Rd		Retail	10,480	Proposed
SEC Hwy 347 & Edison St		Retail	5,000	Proposed
NEC Edison Rd & John Wayne		Retail	100,000	Proposed
TOTAL			392,775	
Source: Elliott D. Pollack & Company; Thompson Thrift; CBRE; NAI Horizon; Commercial Properties, Inc.; Phoenix Commercial Advisors; Kidder Matthews; SRS Real Estate Partners; Newmark; Cushman & Wakefield				

The map below displays the supply of available commercial land in proximity to the subject site. There are numerous commercial sites located along John Wayne Parkway and Maricopa-Casa Grande Highway, as well as along SR 238 and White and Parker Road. Every one of these sites are competing with the subject site property to attract commercial development. Additionally, compared to expected demand, commercial land in the area is considered excessively oversupplied. Many of the sites will not be needed for commercial development.

¹ <https://www.inmaricopa.com/catalyst-residential-growth-spurs-commercial-activity/>



Commercial Supply Map – Primary Market Area

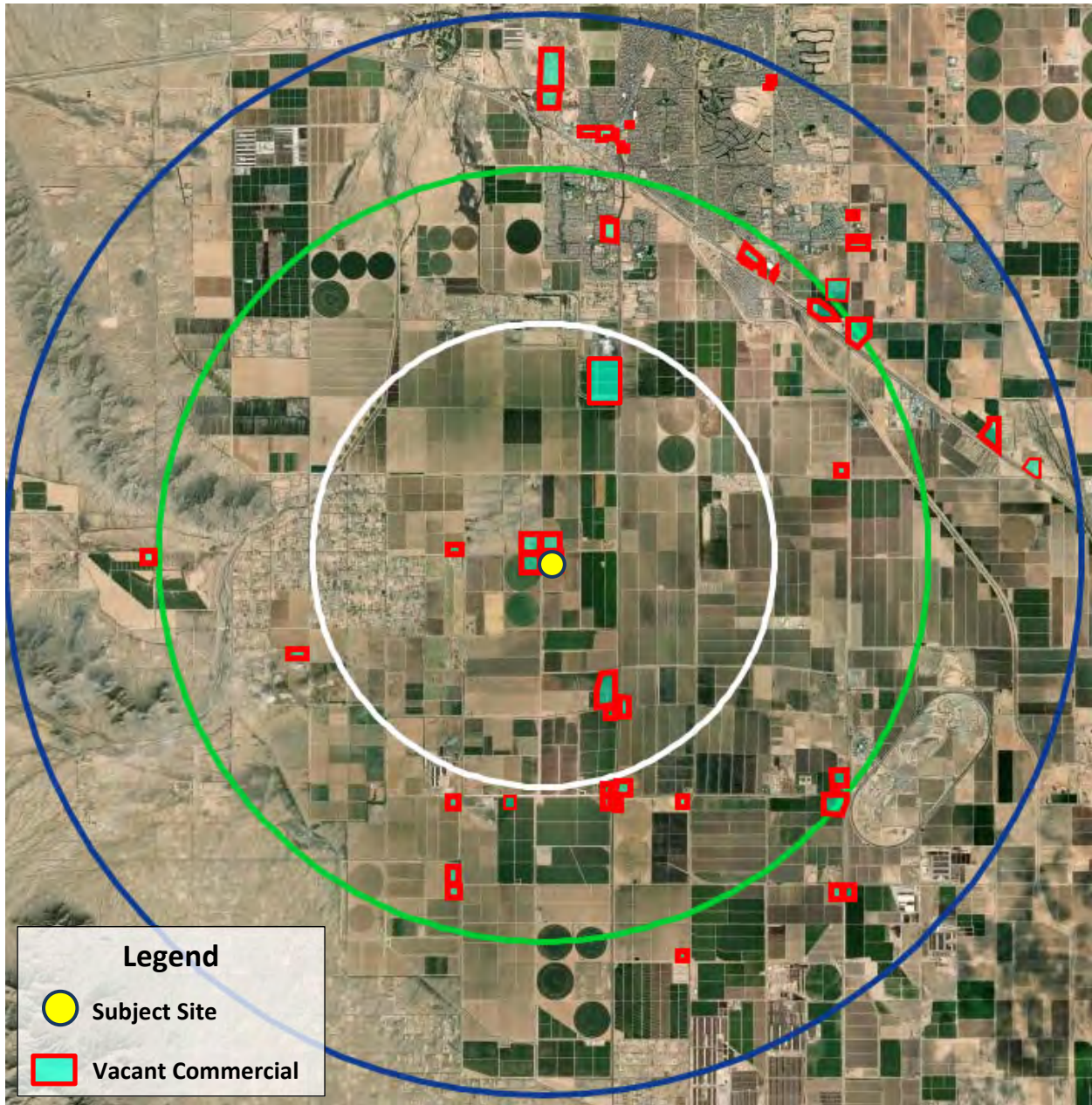

The subject site is at a disadvantage competitively with many of the alternative sites. First and foremost, retailers will prefer most of the sites located to the north that are closer to the city center, either in the area of Maricopa-Casa Grande Highway and Porter Road or along the SR 347 in the northern portion of the city. Residential developments in the southern area around the subject site would be considered part of their trade area and will make the drive to retail centers to the north. There is currently far too much risk to locate outside of the concentration of populated city boundaries. Also, with frontage along major roadways such as SR 238, SR 347,



Porter Road, White and Parker Road, and Maricopa-Casa Grande Highway, these competing sites enjoy better visibility and substantially higher traffic volumes. In contrast, the subject site is located one mile west of SR 347 Highway (John Wayne Parkway), providing no highway frontage or visibility with the only frontage along Papago Road and Green Road.

The Ak Chin Indian Community also sits to the area north of the subject site and south of the City of Maricopa. As the General Plan map and zoning map illustrate, Ak Chin Indian Community has designated a one-mile stretch of SR-347 frontage starting south of Farrell Road as Commercial. Frontage on the north half mile contains Harrah’s Ak Chin Casino and Hotel and the Ak Chin Circle Entertainment Center which includes movie theaters, bowling, arcade gaming, event facilities, outdoor amphitheater, and dining.

Ak Chin Indian Community also extends an additional one mile south down to Paters and Nall Road. Currently, the land use plan designates the east and west side of SR 347 as agriculture. However, the Community has shown that they are interested in continuing commercial development and could reclassify these areas for commercial uses as well.

Ak Chin Indian Community Land Use Map

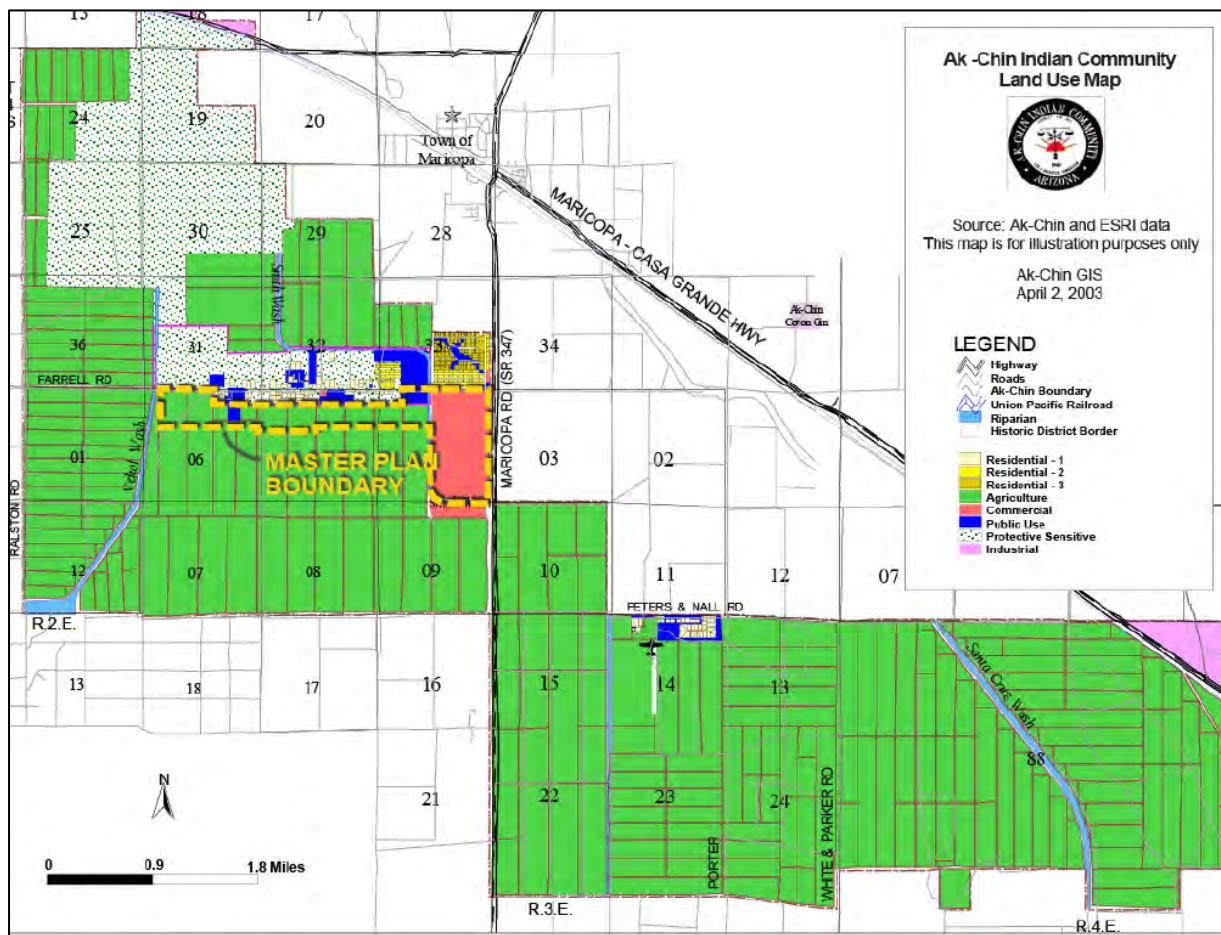

The proposed plan is compatible with the Pinal County Comprehensive Plan which denotes high intensity and medium intensity activity centers throughout the County which would be targeted for commercial and employment uses. The Comprehensive Plan chooses high traffic highways and arterials for these activity centers around the City of Maricopa, including SR 347, SR 84, and the Maricopa-Casa Grande Highway. The subject site is located in an area designated for moderate low density residential.

Pinal County Comprehensive Plan

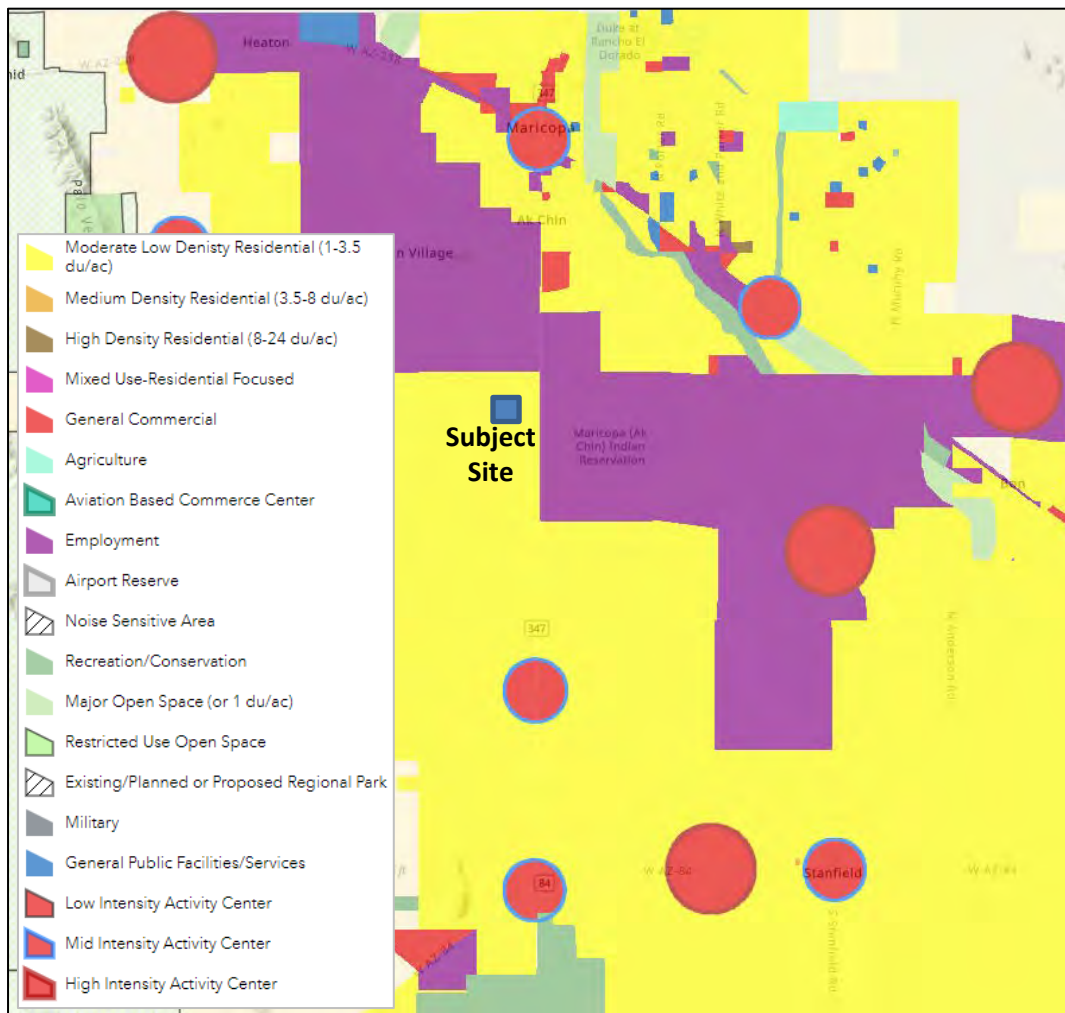

The subject site also has three competing sites in close proximity, all with significant frontage along Papago and Green Road and range in size from 15 to 32 acres. All four corners at the intersection of Papago Road and Green Road are designated for commercial or mixed-use development.

Clearly, there are too many sites for commercial development. This is especially true considering the extremely modest population base and relatively low level of future residential development



expected in this southern area. Even when the subject site’s proposed developments and neighboring subdivisions build out, it will not be sufficient to trigger enough retail demand that the acreages offered on the available parcels can accommodate.



The disadvantages to competing sites identified above, combined with the fact that there is an excess of commercial land in the area, bodes poorly for the subject site’s prospects to generate retail or other commercial development interest.

The proposed change to residential development will help support future retail assets within the PMA. Each new additional resident will create demand for additional local serving retail.

Continued residential development in all forms within the market area will be critical to the eventual success of existing retail assets and additional commercial development. As the following graphic helps to illustrate, local residents will be the main source of retail demand. This residential development must come first, eventually building to a critical mass of residents to attract additional retailers.

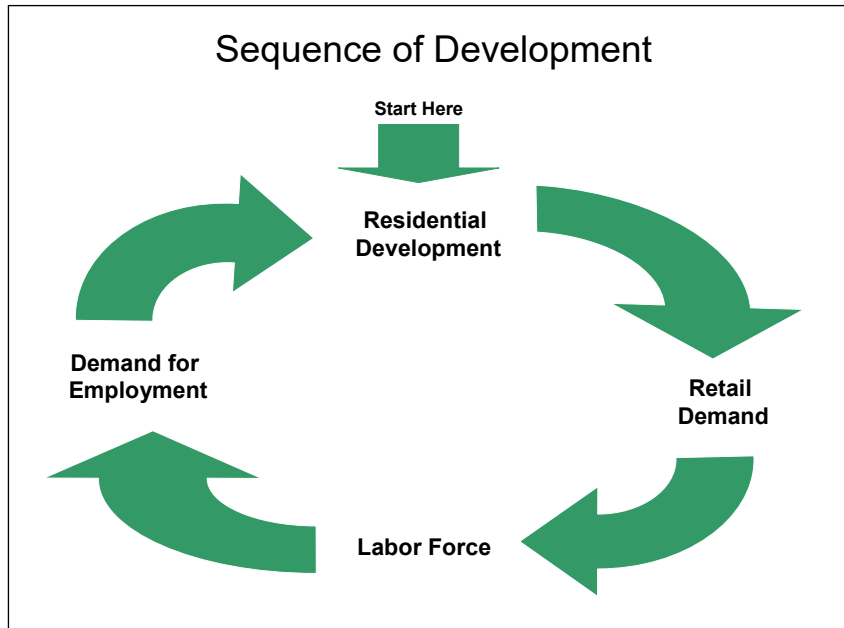

In our opinion, the rezoning of the subject site to residential uses will not affect the region's efforts to continue to attract new commercial development to the community. The area has a significant inventory of commercial land that will provide for the long-term economic health of the community. Additionally, as a residential project, new residents will support existing and planned commercial development. Overall, the proposed change for residential uses:

1. Is compatible for the site given its characteristics, neighboring developments, and location. It is also compatible with the Pinal County Comprehensive Plan.
2. Will accommodate new resident growth which will support existing and planned commercial development.
3. Will not harm the county's efforts to continue to attract new commercial development to this region of Pinal County based on available land compared to expected demand.
4. Recognizes that many alternative sites have competitive advantages over the subject site in terms of location, visibility, surrounding assets, and interest from retailers.



1.0 Purpose of Study

The purpose of this analysis is to determine the current and future demand for regional and local serving retail (including restaurants) in the market area surrounding the 15-acre subject site located at the southeast corner of Papago Road and Green Road. Our analysis will consist of evaluating the current size of the Primary Market Area, its potential development capacity, the supply of retail and available land, as well as the demand for commercial uses based on the surrounding market area population, the demographic characteristics of that population, and future growth.

1.1 Report Outline

Our study will consist of the following tasks.

1. Identification of the market area surrounding the subject site that would provide most of the demand for the project.
2. A summary of the demographic characteristics of the population in the market area.
3. Current and forecasted population growth estimates for the market area.
4. Supply of available retail space and land in the market area.
5. A forecast and summary of recommendations on the potential demand for commercial uses within the Primary Market Area based on market conditions.

1.2 Limiting Conditions

This study prepared by Elliott D. Pollack & Company is subject to the following considerations and limiting conditions.

- It is our understanding that this study is for the client's due diligence and other planning purposes.
- The reported recommendation(s) represent the considered judgment of Elliott D. Pollack and Company based on the facts, analyses and methodologies described in the report.
- Except as specifically stated to the contrary, this study does not give consideration to the following matters to the extent they exist: (i) matters of a legal nature, including issues of legal title and compliance with federal, state and local laws and ordinances; and (ii) environmental and engineering issues, and the costs associated with their correction. The user of this study will be responsible for making his/her own determination about the impact, if any, of these matters.



- This study is intended to be read and used as a whole and not in parts.
- Our analysis is based on currently available information and estimates and assumptions about long-term future development trends. Such estimates and assumptions are subject to uncertainty and variation. Accordingly, we do not represent them as results that will be achieved. Some assumptions inevitably will not materialize and unanticipated events and circumstances may occur; therefore, the actual results achieved may vary materially from the forecasted results. The assumptions disclosed in this analysis are those that are believed to be significant to the projections of future results.



2.0 Retail Market Overview

Market conditions existing today in the retail real estate sector have been severely affected by the growth of E-Commerce, the Great Recession, and most recently the economic shutdowns created by the COVID-19 pandemic. The last business cycle (2009-2020) exposed significant longer-term challenges for the brick-and-mortar retail market in Greater Phoenix and across the country. Compounding those issues, the COVID-19 pandemic suppressed local retail shopping in all but the most popular warehouse stores and grocers and shifted shopping patterns to online retailers. Future changes in shopping trends that will affect how the market performs over the long term. Following are some of those trends and challenges.

- **Domination:** The market has become dominated by big box retailers and power/community shopping centers.
- **Obsolescence:** Retailing is constantly changing resulting in some companies going out of business as others are entering the marketplace. Part of the problem for companies that are experiencing difficulties is the inability to anticipate trends in shopping patterns and the impact of alternative methods of purchasing goods and services. Currently, restaurants and value-oriented retail such as Walmart, Target, Ross, TJ Maxx, and others are the most viable in the market and actively expanding. The list of retailers and restaurants that are in bankruptcy or have been in bankruptcy is extensive and include:
 - Sears
 - Toys “R” Us
 - Sport Authority
 - Aeropostale
 - Beauty Brands
 - Shopko
 - Gymboree
 - Charlotte Russe
 - Payless Shoe Source
 - Diesel
 - Z Gallerie
 - Kona Grill
 - Perkins and Marie Callender’s
 - Barneys New York
 - Forever 21
 - Destination Maternity
 - Avenue
 - Pier One
 - Charming Charlie
 - FTD
 - David’s Bridal
 - Mattress Firm
 - Gump’s
 - Brookstone
 - Rockport
 - Nine West
 - Claire’s
 - Winn-Dixie
 - Bon-Ton
 - Rue21
 - BCBG Maxazria
 - Wet Seal
 - The Limited



The types of retailers that have experienced bankruptcies fall into a few categories. Bookstores long ago experienced significant declines in sales. More recently, clothing and accessory retailers, including shoe retailers, have experienced the most difficulties along with department stores and grocery chains. Department store sales have been declining for decades with the growth of low-cost supercenters and warehouse outlets. Grocery stores have come under attack from a wide range of retailers that have moved into the grocery business.

The traditional department store will continue to likely see declining sales. Macy's and Kohl's have reported sales slumps. JC Penney recently emerged from bankruptcy after being purchased by Simon Property Group (SPG) and Brookfield Asset Management.

- **Greater Phoenix is Over-Retailed:** Because of the Greater Phoenix region's tremendous history of growth, virtually all national retail chains want to be here, resulting in more retail space than is demanded by the population. According to the Lincoln Institute of Land Policy, the U.S. has 8.5 billion square feet of retail shopping center space or 24.5 square feet per person. By comparison, Maricopa County's population of more than 4.4 million has 34 square feet of retail space or 38% more than the national average. In the past, many national retail chains built stores in advance of growth to establish their market area. When growth slowed during the Great Recession, many planned stores were put on hold or abandoned. The coronavirus pandemic has further disrupted the growth of retail centers across the country and in Greater Phoenix.
- **Consolidation:** As retail market conditions change, consolidation of companies within the industry occurs. This trend has been particularly evident in the grocery store sector as chains try to compete with Walmart, Target and Costco. Local grocer Bashas' has been through bankruptcy and is likely still vulnerable.
- **Internet or E-Commerce Sales:** The long-term threat to brick-and-mortar retailing (and shifts from retail development to warehousing and distribution) is E-Commerce. Within the last 15 years, the market has seen seismic shifts in the manner in which people purchase retail goods and services. The COVID-19 pandemic has further pushed consumers towards internet-based purchases. Certain segments of the retail market have been particularly hard hit. A later section of this report will provide further information on the E-Commerce trend.

In summary, there are two major trends that have had a significant impact the retail market:

1. E-Commerce and
2. The rise of off-price retailers and low-price supercenters and warehouse outlets.



2.1 Impacts of E-Commerce

The U.S. Census defines E-commerce as “sales of goods and services where the buyer places an order, or the price and terms of the sale are negotiated, over an Internet, mobile device, extranet, Electronic Data Interchange (EDI) network, electronic mail, or other comparable online system. Payment may or may not be made online”.

The above definition technically excludes mail order sales from catalogs or other mail-order businesses. It does not include such businesses as mail-order book clubs. However, most catalog and book club purchases today are made over the internet and should properly be categorized as E-Commerce. For this study, mail order sales will be included in E-Commerce sales data.

Between 2000 and 2021, E-Commerce sales have grown by over eight-fold to \$947.6 billion, accounting for 14.4% of all retail sales in 2021. The coronavirus pandemic had a significant impact on retail sales patterns pushing normal in-store purchases to online. While only preliminary data for 2021 is available, the latest data from the U.S. Census shows that through December 2021 E-Commerce sales have increased by 6.6% over 2020. This follows an annual increase of 35.2% in 2020.

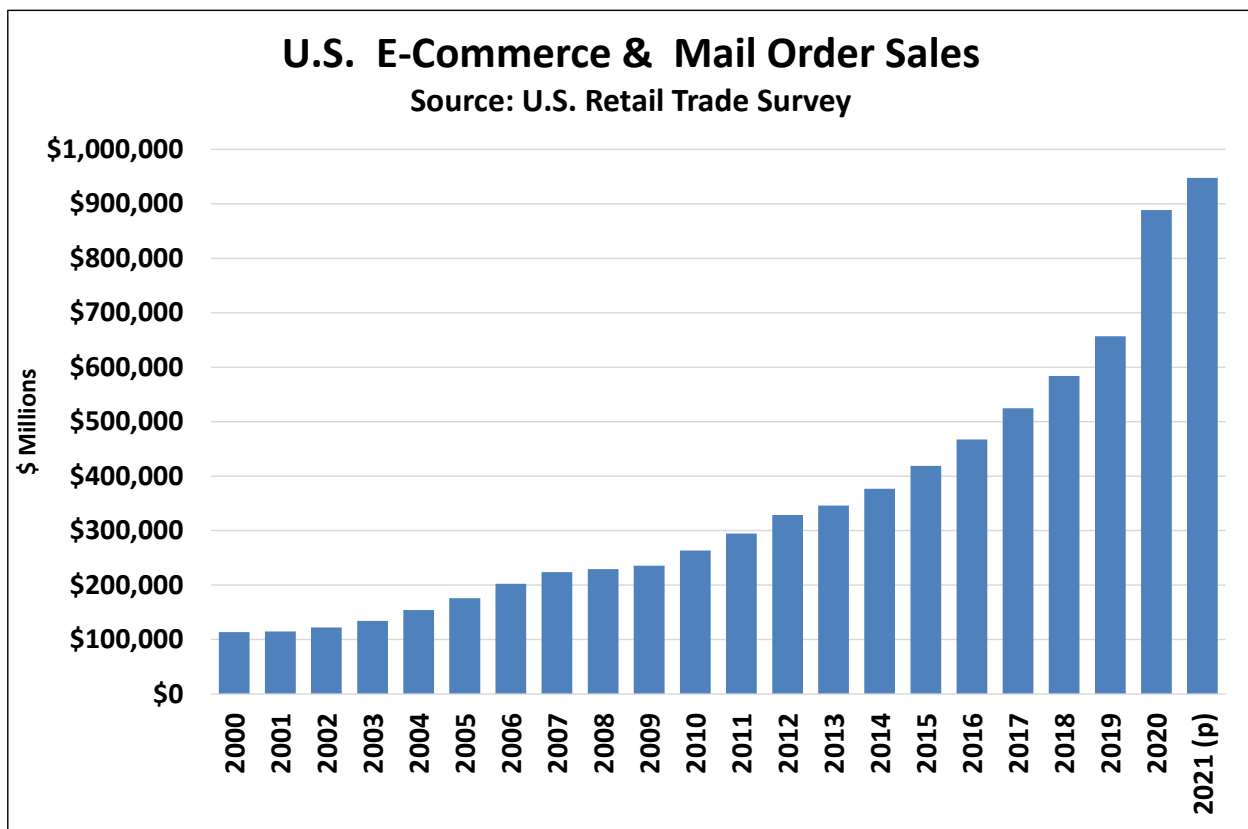

1.



Comparing preliminary 2021 data, E-Commerce sales comprised 14.4% of total sales. Due to the shutdown of the economy in March 2020 and peoples' desires to avoid crowds through the rest of the year, an above trendline portion of retail sales went to electronic shopping in 2020. While finalized data is not available for 2021, it appears that the number of COVID cases decreasing, and vaccination rate increases have brought a return to in-store shopping. However, even if 2020 represents an anomalous spike, 2021 saw continuation of growth and continued the upward trend of online sales.

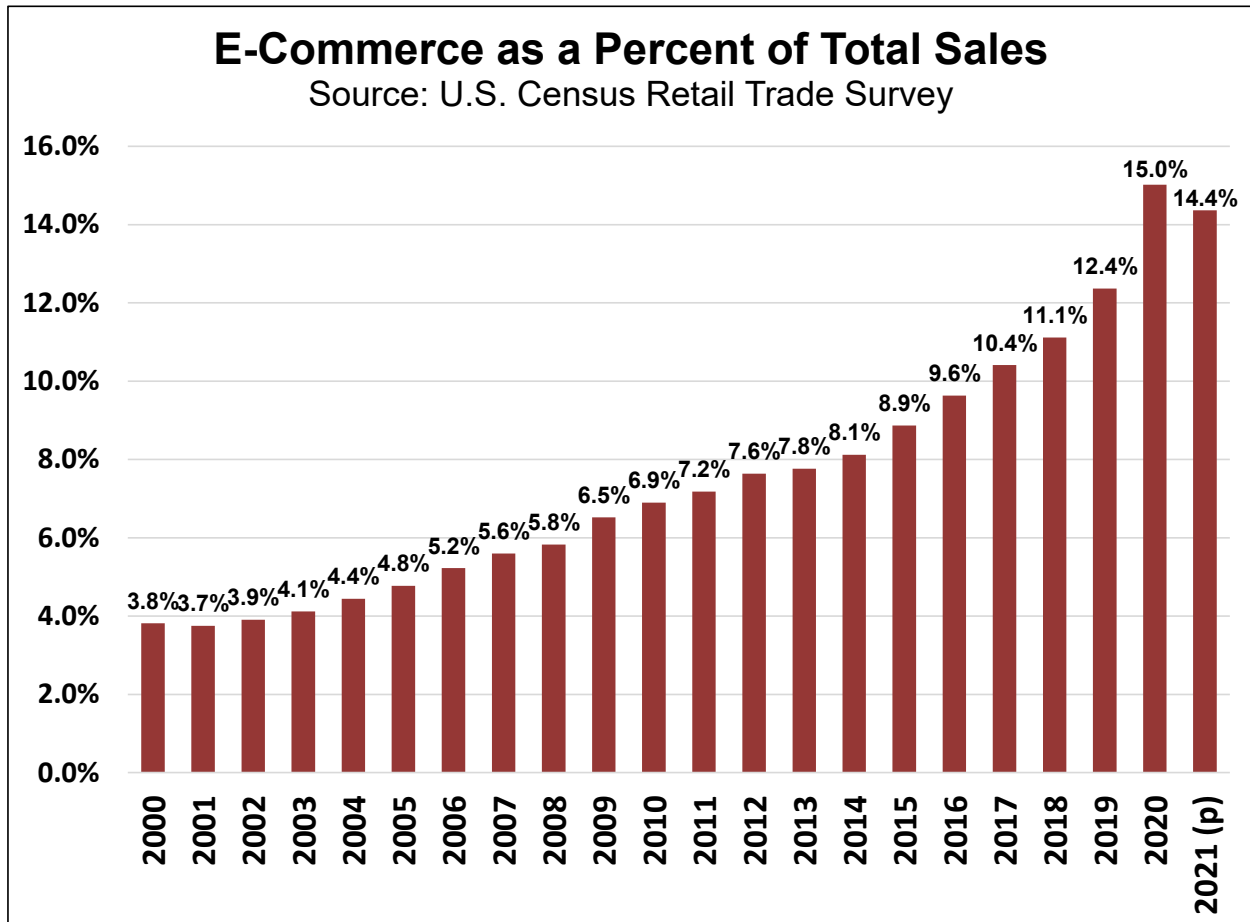

2.2 Impact of Superstores and Warehouse Clubs

In addition to the impact of E-Commerce on brick-and-mortar outlets, the expansion of superstores, such as Target and Walmart, and warehouse clubs, such as Costco, has resulted in a shift of retail spending from traditional department stores and small retailers. Off-price and value-oriented retailing has become the driving force in the retail sector. The following chart illustrates the shift in spending.



In 2000, spending at traditional department stores in the U.S. totaled more than \$96 billion. Today, that spending has declined to less than \$36 billion, resulting in the closure of many national and regional department store chains and bankruptcies such as Sears. By comparison, spending at supercenters and warehouse clubs ballooned from \$140 billion in 2000 to \$594 billion in 2021. Power centers anchored by Walmart, Target, Home Depot, Lowes and similar big-box retailers have become the primary outlets for retail sales.

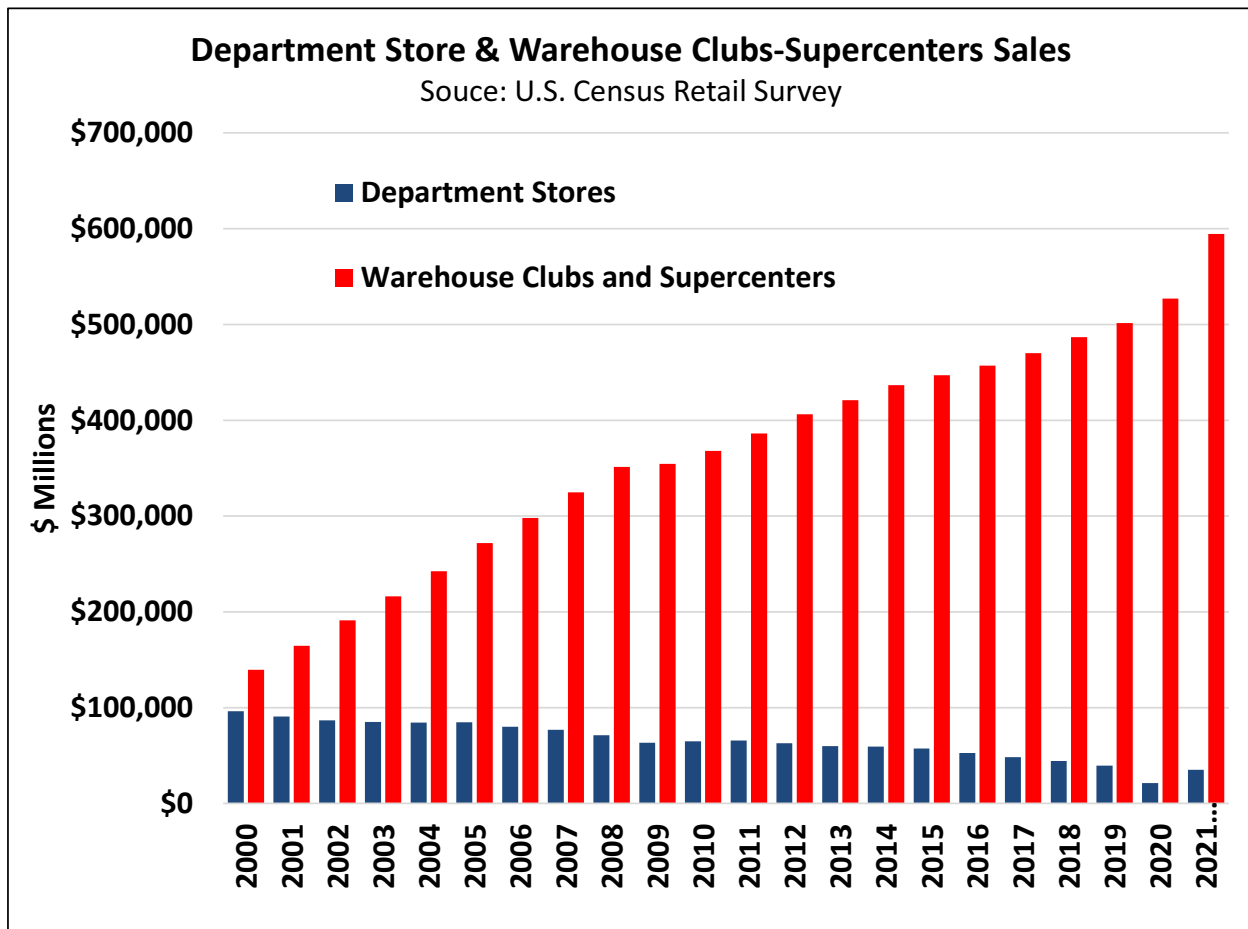

2.3 COVID-19 Impacts

The trend away from consumer spending in department stores has been occurring over the past 20 years and is likely now accelerated due to COVID-19. Retailers that have fared well during the pandemic include Walmart, Target, Home Depot, and a variety of grocery store chains. However, there were declines in sales at many other retailers. Restaurants and bars sustained significant reductions, as did fitness centers. The reopening of the economy has allowed these establishments to offset some losses, but some portion has been lost permanently.



The following chart provides some insight into retail sales patterns due to the pandemic. The data compares U.S. spending in April 2020 to April 2019. Virtually all retail sectors experienced substantial losses, especially clothing, furniture, motor vehicles, sporting goods, department stores, and restaurants and bars. Those that gained sales were building materials, groceries, and non-store retailers (E-Commerce). Even general merchandise stores, which includes Walmart, Costco, and Target, showed a loss of sales. Preliminary data shows these three retailers experienced growth in sales in April, but it was not enough to offset the losses of other general merchandise operators. Non-store retailers, primarily comprised of E-Commerce retailers, were the clear winners. The data shows the consumer's preferences for essential purchases while honoring stay-at-home recommendations. Non-essential purchases shifted to E-Commerce to avoid travel and congregating in crowds to socially distance.

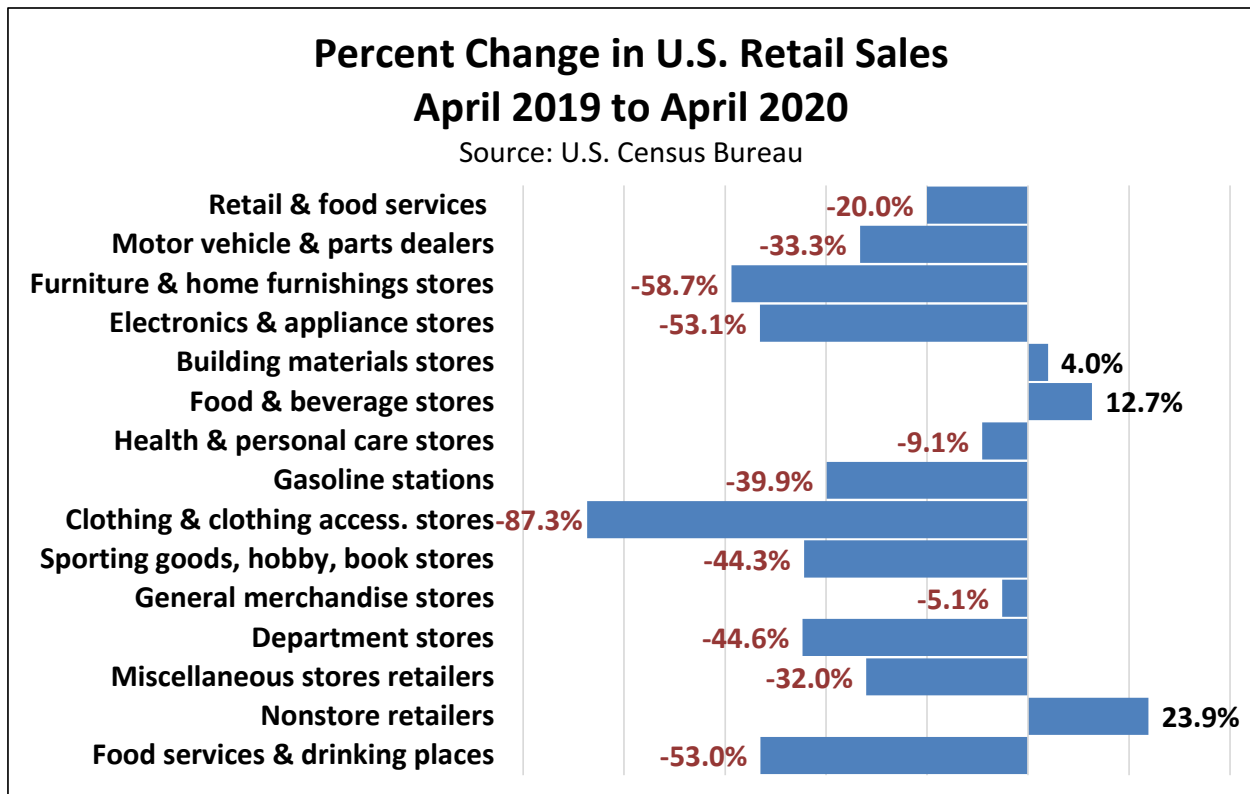

2.4 Greater Phoenix Retail Market

The Greater Phoenix retail market vacancy rate has experienced a gradual decline over the last decade from its previous peak of over 12% to 7.1% in the third quarter 2021. However, even with the tightening of the market, new construction activity remains disciplined. Construction activity is dominated by grocery-anchored projects with Sprouts, Fry's and Whole Foods as primary tenants. Power center development has largely been absent from the market.



Much of the absorption of space in Greater Phoenix over the past few years has been due to fitness and entertainment users backfilling vacant big-box and grocery store space. Since 2016, fitness users have absorbed 35 big-box spaces totaling over 1.0 million square feet. Due to demand for affordable fitness concepts, users like EoS Fitness, Planet Fitness, and LA Fitness are adding to their existing footprints. Newcomers include Crunch Fitness and VASA Fitness.

Even with the population and employment growth of Greater Phoenix area over the past two years, the retail market has not responded with significant construction activity. Greater Phoenix is in the top three metro areas in the country in job and population growth. Delivered retail space still is well below historic levels. Once again, E-Commerce and the popularity of supercenters and warehouse outlets is limiting extensive development of new retail space.

Since 2010, retail space delivered to the market has averaged 650,000 square feet annually or the equivalent of three to four neighborhood shopping centers each year. In 2020, only 286,300 square feet of retail space was delivered. Deliveries through the third quarter of 2021 total 301,890 square feet, well below the already modest 10-year average.

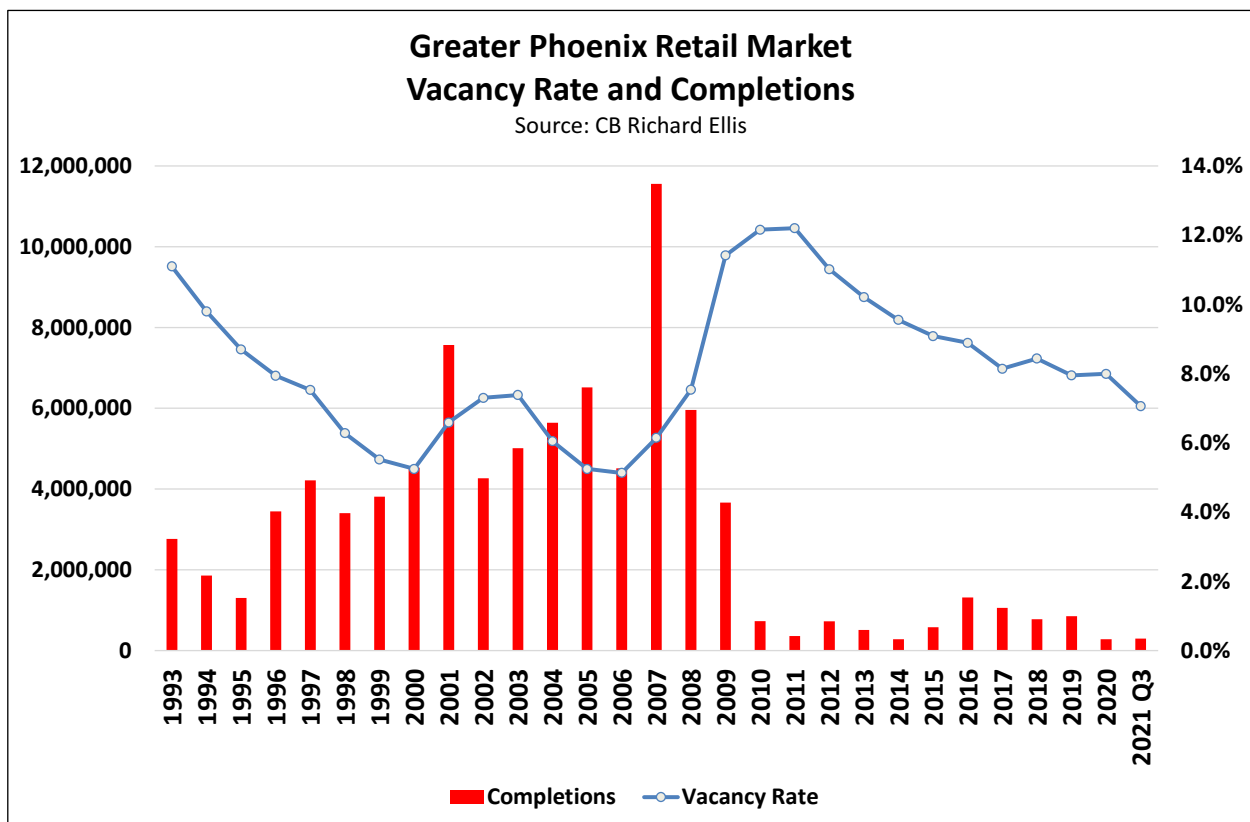

2.5 Maricopa Retail Market

The subject site is located south of the City of Maricopa and Ak Chin Indian Community in the West Pinal County submarket. Due to its location on the periphery of development in the Valley, trade areas for regional retailers are quite large. Locations in the City of Maricopa consider the residents of this area to be part of their customer base.

Maricopa has gradually cultivated a healthy mix of retail development, including a cluster of neighborhood shopping centers anchored by grocery stores and a Walmart Supercenter. There is approximately 1.1 million square feet of retail space and occupancy is strong, with only approximately 41,800 square feet of vacant space.

The range of types of retail outlets and merchandisers is still somewhat limited due to its population size but provides for many of the daily needs of residents, including many restaurants. A number of grocery retailers are located in the area, with a new Sprout's under construction at Edison and John Wayne Parkway. While many of these retail locations are located some distance from the subject site, they are still within a reasonable drive and on the typical commuting route for many area residents.

An aerial photo of the primary anchor tenants in relation to the subject site's Primary Market Area is provided below.



Major Retailers – City of Maricopa



3.0 Market Area Overview

3.1 Market Area Description

The Primary Market Area (PMA) is defined as the geographic area from which demand for a particular real estate product will arise. It is also the area containing similar and, therefore, directly competitive real estate projects. For this analysis, the focus of the primary market area surrounding the subject site is for local-serving, neighborhood retail development. For purposes of this report, the competitive market area will be called the Primary Market Area (PMA).

When conducting a market study, one of the most important steps is defining the project's primary trade, or market area. The first step in evaluating an appropriate market area is to analyze the characteristics of the neighborhoods immediately adjacent to the subject property. Typically, the market area includes the property three to five miles from the subject site, adjusted for the real estate product (in this case local serving retail such as grocery, personal and household services, restaurants, etc.), geographic features, socioeconomic conditions or economic circumstances.

It is common to utilize major freeways, or roads near major freeways, as market area borders since they often define neighborhoods within which people reside, shop and recreate. People become accustomed to residing in a particular part of the metro area and often do not stray far from those areas when relocating their place of residence. Natural topographic features are also a factor that affects people's living preferences and habits.

Based on analysis of the geographic features of the area and the layout of census tracts, existing neighborhood retail assets, preferable drive time for neighborhood retail, interviews with developers and economic development experts, as well as the experience of this firm in conducting market studies for neighborhood retail developments, a range of three to seven miles was used to evaluate the strength of the subject site for retail development. The three- and five-mile radius from the subject site that would be considered a typical Primary Market Area contained very little retail inventory and existing population. It was important to capture additional market data in a seven-mile radius to more fully capture the City of Maricopa region.

The PMA range for the subject site recognizes both the transportation network and the substantial competition to the north and the likely preference of residents north of the subject site to prefer those locations in Maricopa based on access while residents to the south have relatively fewer options and may consider visiting the site as a retail option.



Primary Market Area

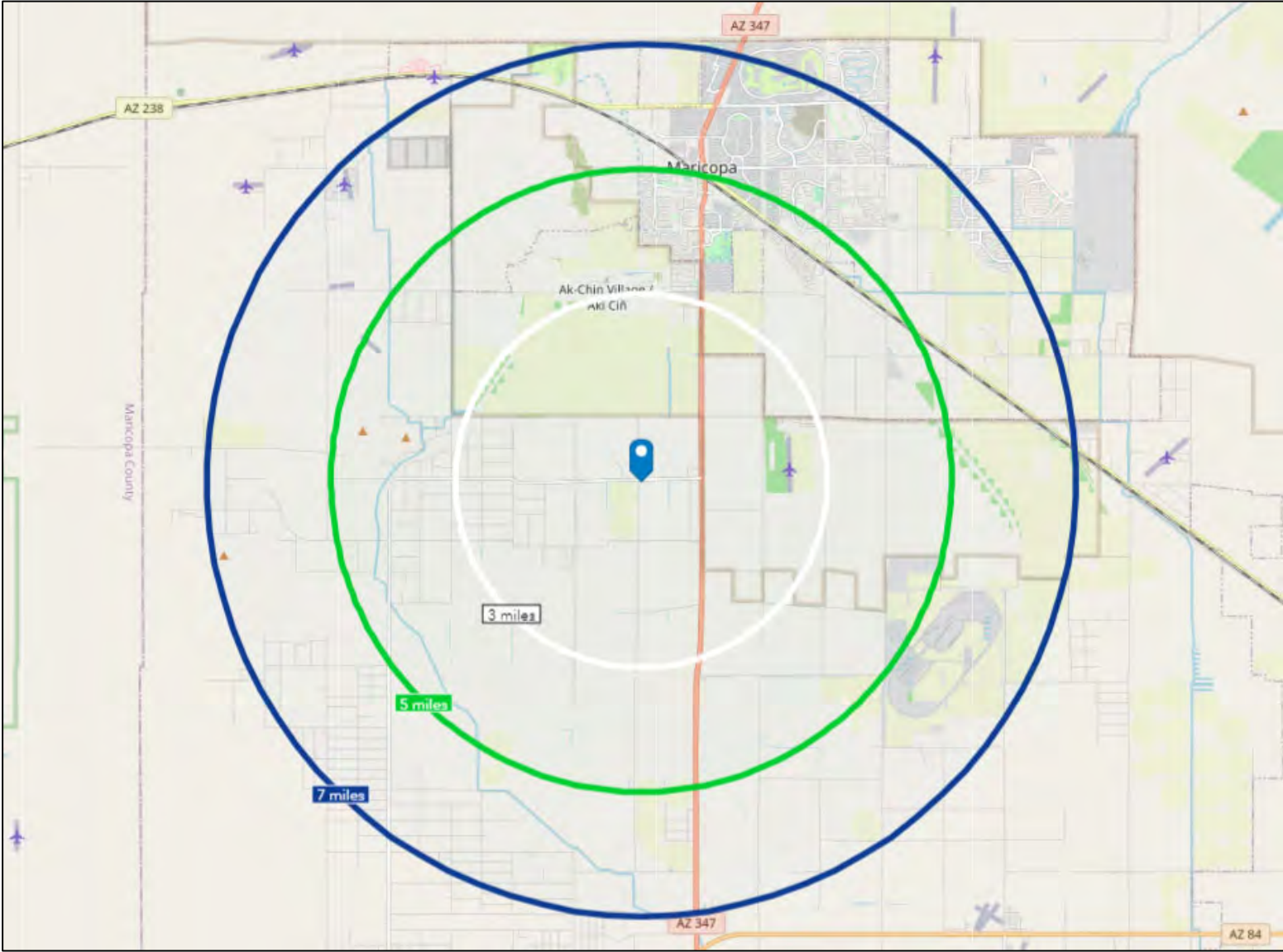

As discussed previously, the defined primary market area is specific to the subject site as the most likely draw by residents. Residents likely spend a portion of their disposable income for local-serving goods outside of these PMA boundaries, but the PMA represents the subject site's most likely area to draw customers from.

3.2 Population & Households

The following table shows the estimated population of the 3-, 5-, and 7-mile rings around the subject site as well as Pinal County for reference. The City of Maricopa in the northern area of the PMA and Pinal County both experienced substantial growth from 2000 to 2010, growing by an average annual rate of 21.8% and 7.7%, respectively. In the subsequent decade from 2010 to 2021, the 7-mile PMA has maintained an average growth rate of 2.6% per year compared to 2.1% in the county. There are an estimated 2.98 persons per household within the 7-mile Primary Market Area.

The 3-mile radius surrounding the subject site is far less populated and has not experienced much growth over the last two decades. This area has seen growth of only 124 households, capturing just 0.8% of growth in the region from 2000 through 2021.

Population Estimates								
	3-Mile		5-Mile		7-Mile		Pinal County	
	Persons	Annual Percent Growth	Persons	Annual Percent Growth	Persons	Annual Percent Growth	Persons	Annual Percent Growth
2000	1,056		3,025		5,559		179,727	
2010	1,278	1.9%	14,144	16.7%	39,829	21.8%	375,770	7.7%
2021	1,431	1.0%	17,079	1.7%	52,992	2.6%	469,799	2.1%

Source: ESRI Business Analyst, U.S. Census Bureau, Census 2010, Esri forecasts for 2021 and 2026.

Income

Median incomes are typically used to judge the well-being of a geographic area since they represent the mid-point of the range of incomes. It will also be utilized in terms of the PMA's ability to support retail development.

Household incomes in the main City of Maricopa area are quite higher than Pinal County averages. Both median income and average incomes are higher in the 7-mile PMA. Median income in the 7-mile PMA is an estimated \$74,799 per household versus \$60,923 across Pinal



County. This data indicates there is above average spending power due to above average disposable incomes among current residents. The 3-mile radius contains much more modest incomes, with a median household income of \$46,371.

Household Income - 2021				
	3-mile	5-mile	7-mile	Pinal County
Total households	468	5,534	17,804	158,790
Less than \$15,000	9.2%	5.5%	5.0%	7.6%
\$15,000 to \$24,999	10.0%	5.5%	4.5%	8.0%
\$25,000 to \$34,999	15.0%	7.4%	6.7%	8.0%
\$35,000 to \$49,999	19.2%	15.3%	12.5%	14.5%
\$50,000 to \$74,999	18.8%	22.8%	21.4%	21.8%
\$75,000 to \$99,999	6.2%	14.8%	16.5%	14.9%
\$100,000 to \$149,999	10.3%	19.0%	21.0%	15.9%
\$150,000 to \$199,999	11.1%	6.9%	8.1%	5.5%
\$200,000 or more	0.0%	2.8%	4.2%	3.7%
Median Income	\$46,371	\$65,590	\$74,799	\$60,923
Avg Income	\$63,307	\$79,912	\$88,021	\$77,597

Source: ESRI Business Analyst, U.S. Census Bureau, Census 2010, Esri forecasts for 2021 and 2026.

Age

The average age of PMA residents ranges from 31.5 to 36.3 years compared to 37.2 for Pinal County. The age demographics are consistent with the incomes found in the area.

Population by Age - 2021								
	3-mile		5-mile		7-mile		Pinal County	
Under 5 years	102	7.1%	1,623	9.5%	4,716	8.9%	34,295	7.3%
5 to 9 years	99	6.9%	1,605	9.4%	4,769	9.0%	34,295	7.3%
10 to 14 years	92	6.4%	1,469	8.6%	4,345	8.2%	32,416	6.9%
15 to 24 years	197	13.8%	2,203	12.9%	6,147	11.6%	54,966	11.7%
25 to 34 years	207	14.5%	2,494	14.6%	7,366	13.9%	64,362	13.7%
35 to 44 years	156	10.9%	2,835	16.6%	8,638	16.3%	64,362	13.7%
45 to 54 years	152	10.6%	1,913	11.2%	5,829	11.0%	50,268	10.7%
55 to 64 years	195	13.6%	1,435	8.4%	4,981	9.4%	51,208	10.9%
65 to 74 years	162	11.3%	1,042	6.1%	4,345	8.2%	51,678	11.0%
75 to 84 years	62	4.3%	393	2.3%	1,537	2.9%	25,369	5.4%
85 years and over	9	0.6%	51	0.3%	265	0.5%	6,107	1.3%
TOTAL	1,431		17,079		52,992		469,799	
Median Age	36.3		31.5		33.9		37.2	

Source: ESRI Business Analyst, U.S. Census Bureau, Census 2010, Esri forecasts for 2021 and 2026.



Educational Attainment

Educational attainment among the residents of the 7-mile Primary Market Area outperforms County averages. There is a higher level of college-educated residents, including those with some college experience, associate's degrees, and bachelor's degrees compared to the County and lower rates of residents with no high school diploma. The PMA also has a higher percentage of residents with a graduate or professional compared to Pinal County. The smaller 3-mile area contains lower educational attainment compared to the broader area and Pinal County, with higher rates of individuals without a high school diploma and generally lower rates of college attendance, though associate's degrees are higher. This is again consistent with household income results.

Educational Attainment								
Highest Educational Level	3-mile		5-mile		7-mile		Pinal County	
	Persons	%	Persons	%	Persons	%	Persons	%
Population 25 years and over	944		10,174		32,986		313,846	
Less than 9th grade	111	11.8%	356	3.5%	1,122	3.4%	14,751	4.7%
9th to 12th grade, no diploma	157	16.6%	916	9.0%	2,111	6.4%	27,932	8.9%
High school graduate/GED	260	27.5%	3,134	30.8%	9,302	28.2%	91,015	29.0%
Some college, no degree	219	23.2%	2,788	27.4%	9,104	27.6%	86,308	27.5%
Associate's degree	103	10.9%	1,068	10.5%	3,727	11.3%	29,815	9.5%
Bachelor's degree	87	9.2%	1,262	12.4%	4,915	14.9%	42,369	13.5%
Graduate or professional degree	8	0.8%	651	6.4%	2,672	8.1%	21,655	6.9%

Source: ESRI Business Analyst, U.S. Census Bureau, Census 2010, Esri forecasts for 2021 and 2026.

3.3 Forecasts

Forecasts for the Primary Market Area from the Maricopa Association of Governments (MAG) are shown on the following table. The entire 7-mile Primary Market Area population is expected to grow by 17,595 persons over the next ten years (5,904 new households). The decade following between 2030 and 2040 is expected to bring an additional 10,343 residents (3,471 new households). From 2040 to 2050 the 7-mile Primary Market Area is expected to increase by 9,747 residents (3,271 new households).

The 3-mile radius surrounding the subject site is projected to grow modestly compared to Maricopa as a whole. This southern region is projected to capture just 8.9% of total growth.



The area between three and five miles is expected to capture an estimated 18.1% of projected growth. The largest growth area is expected to occur between five and seven miles from the subject site to the north, projected to capture 73% of total growth. This is consistent with current growth patterns and commercial development locating in proximity to the population base.

Employment in the market area is anticipated to grow 4.4% per year from 2020 to 2030 which would add 3,117 new employees to the area. Jobs are expected to increase by another 3,879 over the following decade (2030-2040) and by an additional 6,270 jobs from 2040 to 2050. The northern area of the PMA is again expected to capture the majority of employment growth.

Forecasts					
Population & Employment					
	2020	2030	2040	2050	2055
3-mile					
Household Population	1,364	2,029	3,499	4,644	5,262
Households	447	665	1,147	1,523	1,725
Growth		218	482	375	203
Jobs	1,134	1,281	1,740	2,580	3,072
5-mile					
Household Population	23,525	27,289	30,508	33,501	35,470
Households	7,638	8,860	9,905	10,877	11,516
Growth		1,222	1,045	972	639
Jobs	3,237	4,551	6,527	8,931	10,375
7-mile					
Household Population	62,792	80,387	90,730	100,477	105,563
Households	21,071	26,976	30,446	33,717	35,424
Growth		5,904	3,471	3,271	1,707
Jobs	5,747	8,864	12,743	19,013	22,036
Source: Maricopa Association of Governments Socioeconomic Projections, 2019					

Within the PMA, areas in the northern portion have the highest concentration of active subdivisions. This includes several master planned developments and subdivisions including Tortosa, Rancho El Dorado, Rancho Mirage Estates, Homestead, Palo Brea, and Santa Rosa Crossing.



Permits in 2020 totaled 1,514 homes. In 2021, permits have totaled 1,801 homes. However, there are only 1,522 available lots remaining in active subdivisions. Future subdivisions (subdivisions that are platted but have not had a permit issued) that were identified in the PMA would provide an additional 2,942 lots for a total of 4,464 new homes.

For perspective, the following map illustrates currently active new home subdivisions within the PMA. As the map illustrates, many of the currently active new home subdivisions are located in the north.

Active New Home Subdivisions

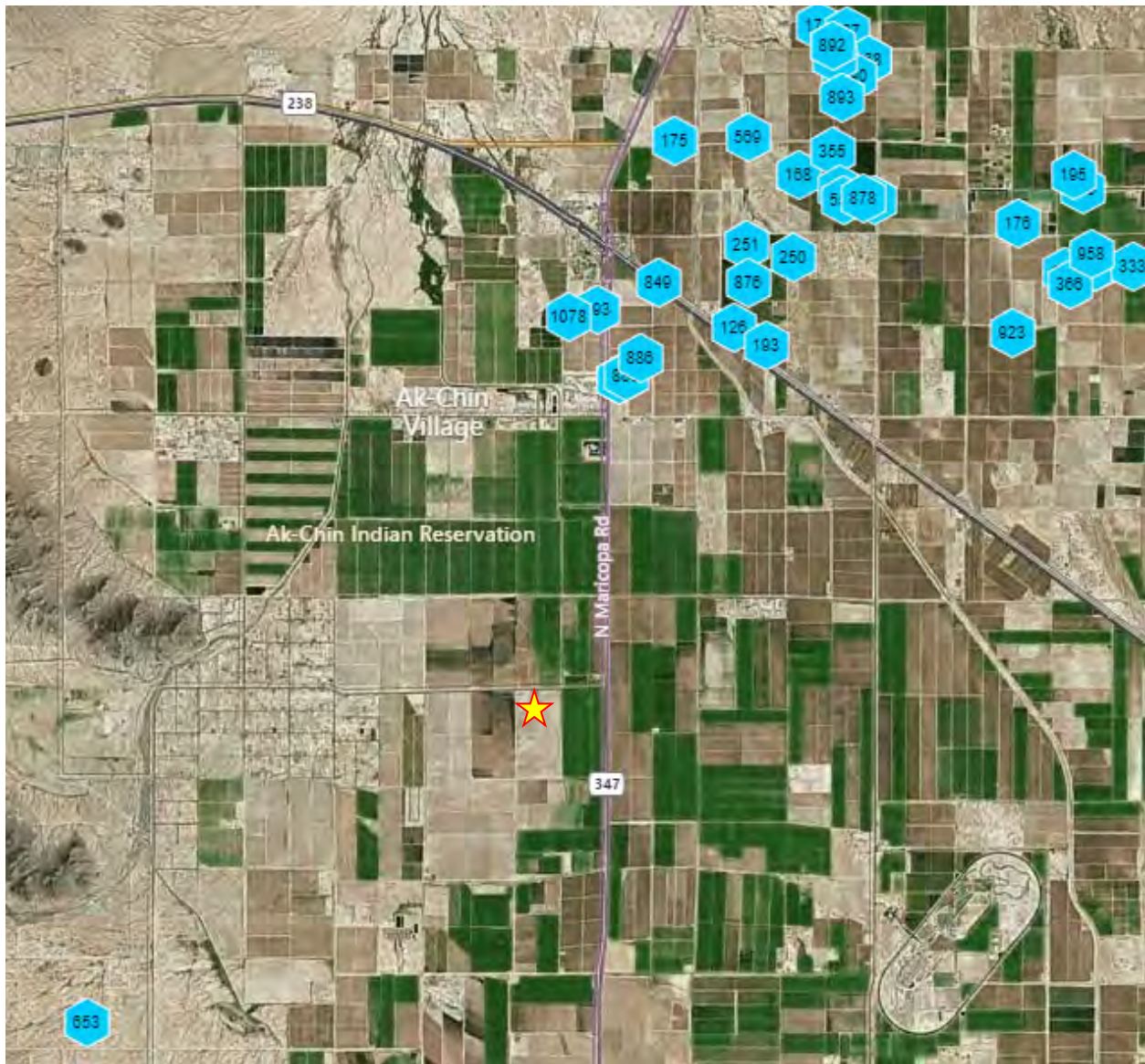

Source: RL Brown



There are also several planned multifamily developments within Maricopa totaling approximately 2,313 units. These projects are also located well north of the subject site in the heart of the City of Maricopa, stretching from Smith Enke Road down to Bowlin Road, approximately four miles north of the subject site.

Existing land uses surrounding the subject site are largely agricultural uses, with substantial residential and commercial development occurring north of the Maricopa-Casa Grande Highway.

Existing Land Use Map

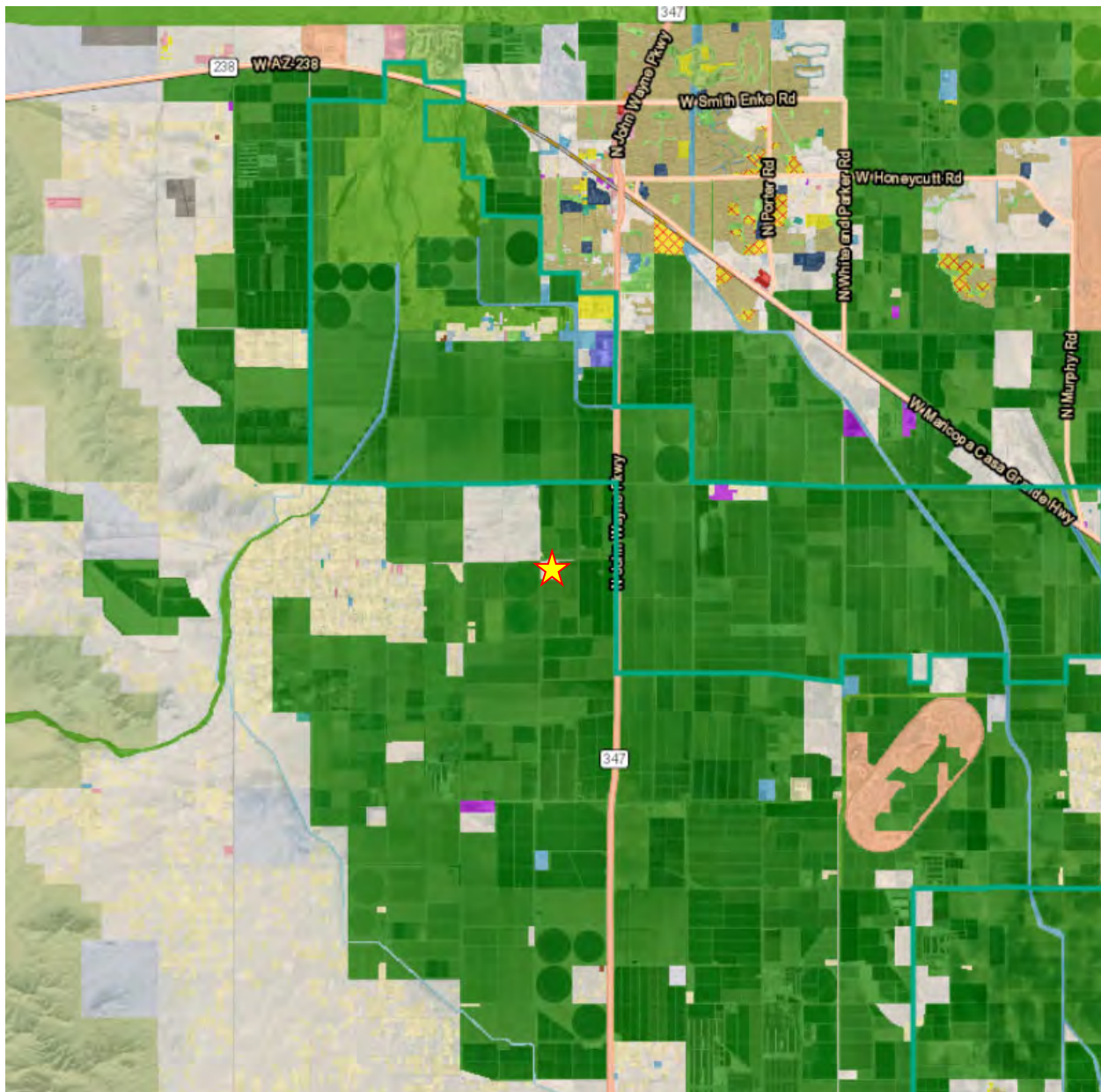

Future land use surrounding the subject site is expected to be a mix of residential, commercial, employment, and mixed uses. Low density residential development is expected to be the dominant land use and will stretch to areas south, east, and west of the subject site, as well as continued development to the north, northwest, and northeast. Continued residential development will eventually support new retail development, which is expected to cluster along major roadways, such as SR 238, Maricopa-Casa Grande Highway, White and Parker Road, and John Wayne Parkway to the north of the subject site as well as SR 347 south of the subject site.

Existing Land Use Map

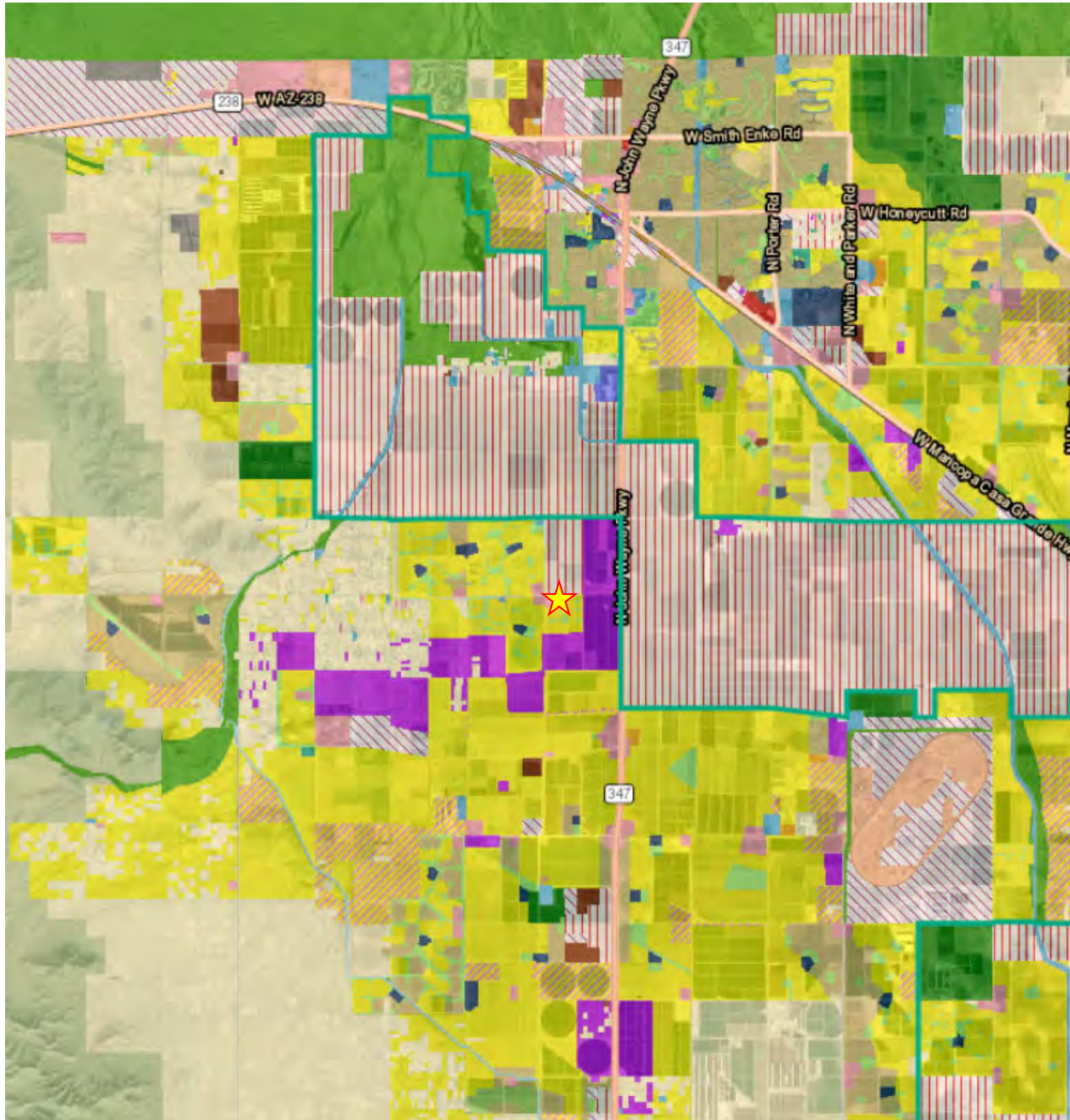

The City of Maricopa’s General Plan envisions several village centers. Village Centers are to be higher intensity areas with high concentrations of commercial and/or employment. In general, village centers are located along the region’s highways and other main thoroughfares. In the southern area, the closest village center is planned for SR 347 and Teel Road. Additional commercial areas and parcels are also identified, the majority of which is along or north of the Maricopa-Casa Grande Highway.

City of Maricopa General Plan – Future Land Use Map

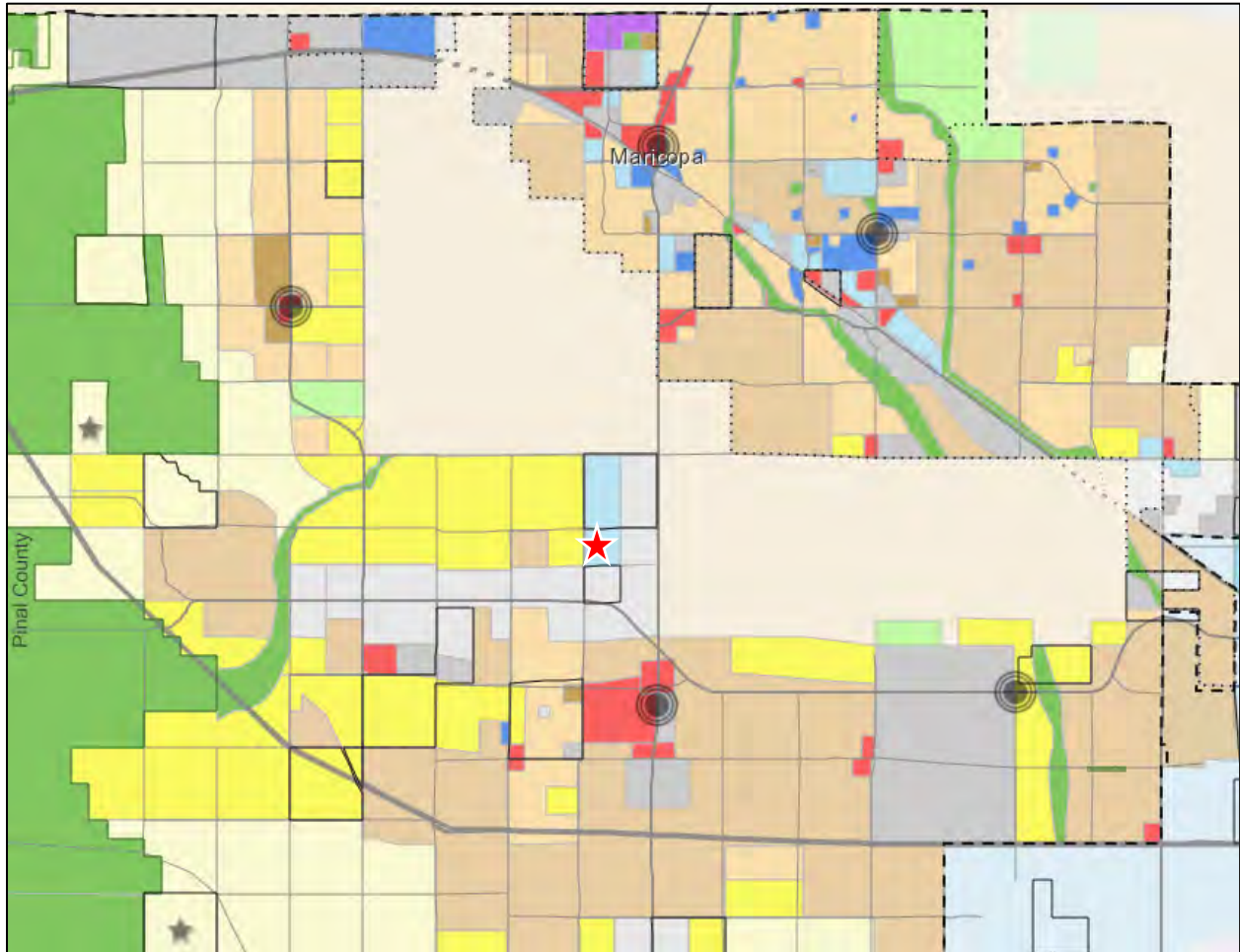

Similarly, the Pinal County Comprehensive Plan denotes high intensity and medium intensity activity centers throughout the County which would be targeted for commercial and employment uses. The Comprehensive Plan also chooses high traffic highways and arterials for these activity centers around the City of Maricopa, including SR 347, SR 84, and the Maricopa-Casa Grande Highway. The subject site is located in an area designated for moderate low density residential.



Pinal County Comprehensive Plan

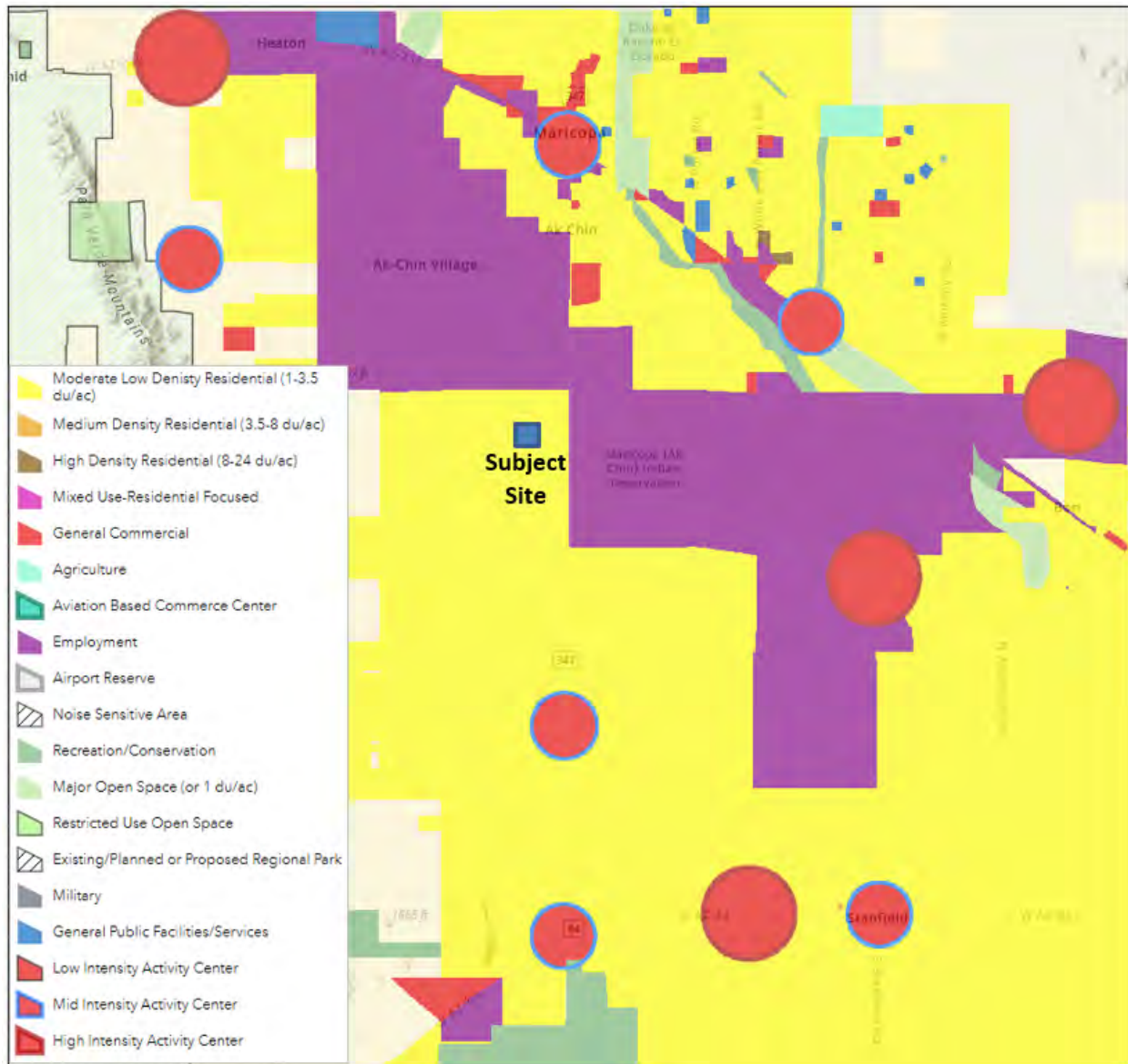

The Ak Chin Indian Community also sits to the area north of the subject site and south of the City of Maricopa. As the General Plan map and zoning map illustrate, Ak Chin Indian Community has designated a one-mile stretch of SR-347 frontage starting south of Farrell Road as Commercial. Frontage on the north half mile contains Harrah’s Ak Chin Casino and Hotel and the Ak Chin Circle Entertainment Center which includes movie theaters, bowling, arcade gaming, event facilities, outdoor amphitheater, and dining.

Ak Chin Indian Community also extends an additional one mile south down to Peters and Nall Road. Currently, the land use plan designates the east and west side of SR 347 as agriculture.



However, the Community has shown that they are interested in continuing commercial development and could reclassify these areas for commercial uses as well.

Ak Chin Indian Community Land Use Map

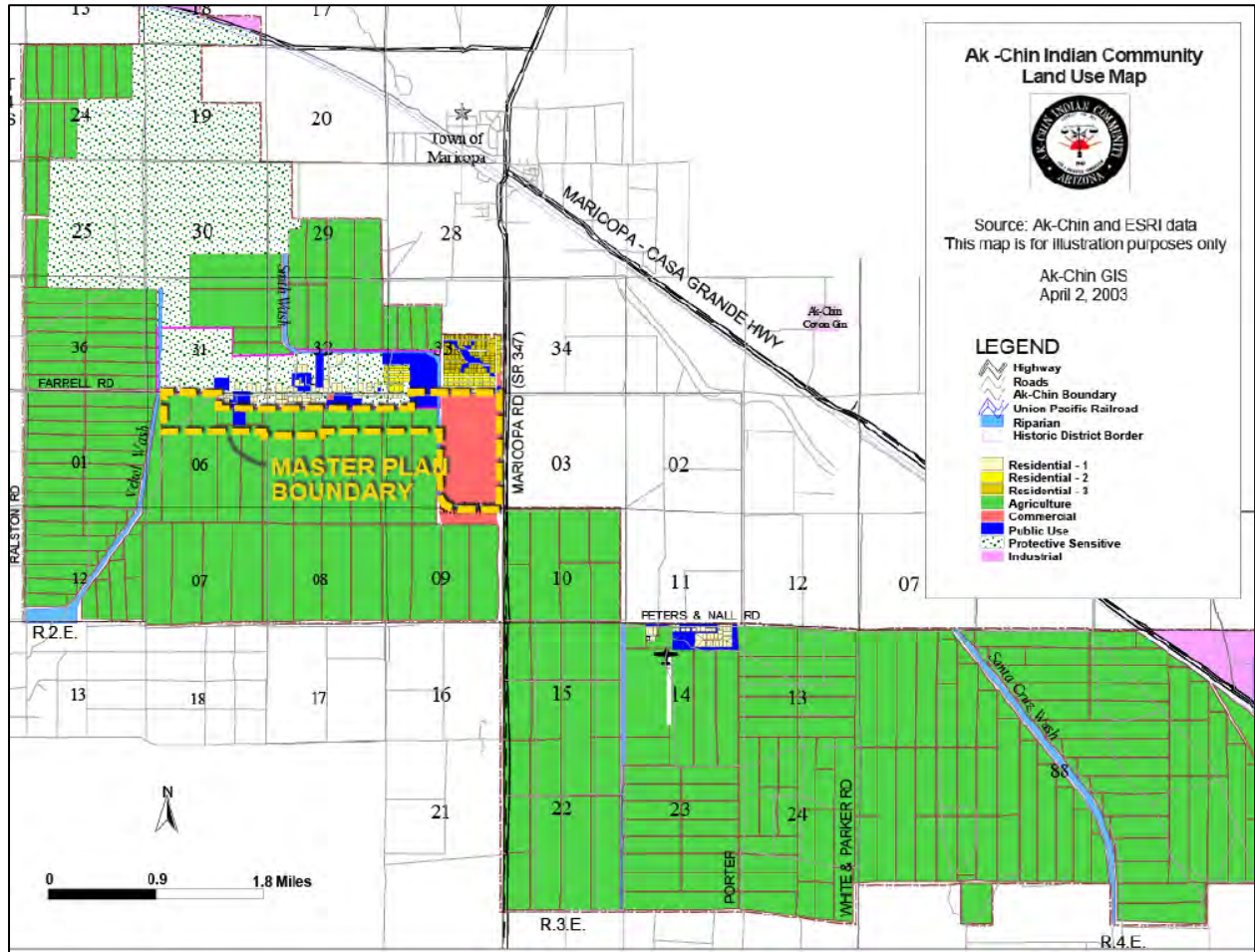

Ak Chin Indian Community Zoning Map

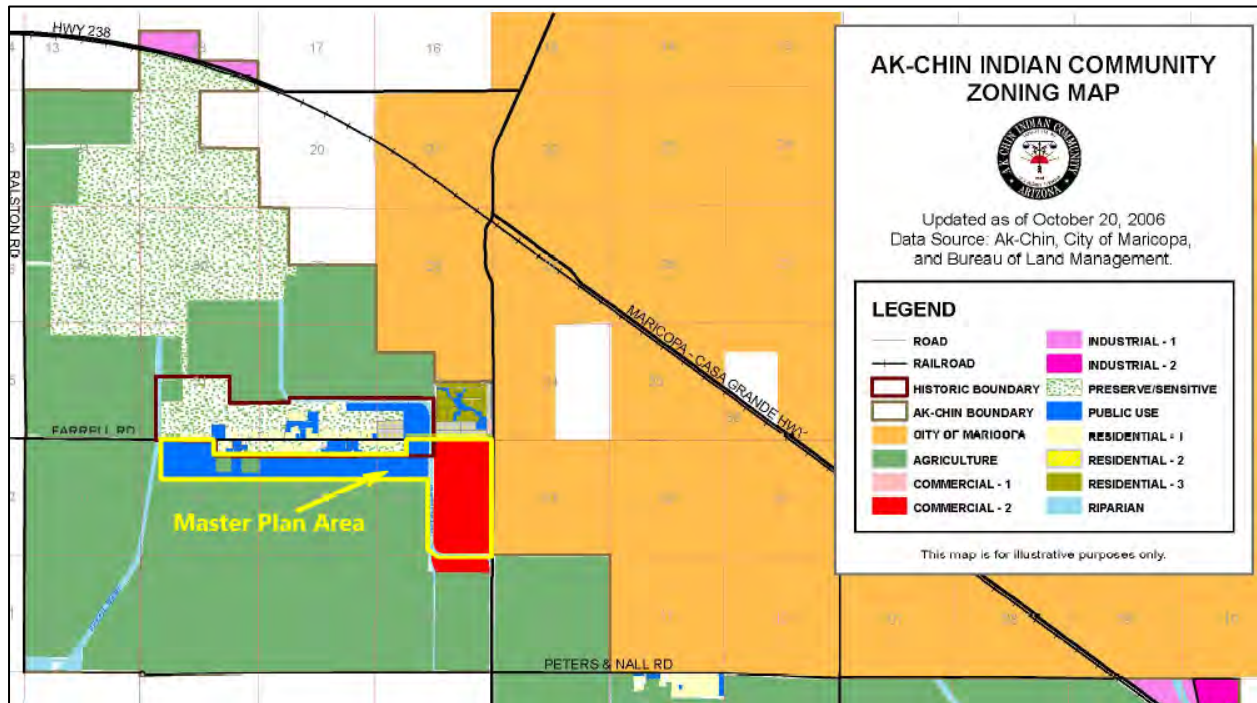

3.4 Summary

The population of the 7-mile Primary Market Area today is estimated at 53,000 persons. The Primary Market Area is expected to increase by at least 5,900 new households between 2020 and 2030. Household incomes also exceed the County median by 23%. Residents have above average levels of education which is also consistent with resident incomes. Overall, we conclude that the Primary Market Area should continue to experience moderate growth trends, concentrated in the northern portions of the PMA.

The southern area and 3-mile radius surrounding the subject site has a much smaller population base and both current and projected population are not conducive to any significant retail developer interest.

While the northern area is still expected to capture the large majority of future growth for the foreseeable future, the southern area is also expected to develop, with numerous plans that were initially conceived during the 2005-2007 housing boom and are now being reconsidered. While still a decade or more away, the southern area is expected to spur some retail development. Expectations are for SR 347 to be the preferred location for a future retail development.



4.0 Retail Supply & Demand Analysis

4.1 Market Area Retail Demand

The current population of the 7-mile Primary Market Area is estimated at 52,992 persons. This population level is considered sufficient to provide support for a moderate level of commercial and retail development.

The Primary Market Area will need to continue to increase in population before additional retail development will occur. Some retailers, such as Walmart, are highly aggressive in establishing their market territory based on growth prospects, even though the current population may not provide optimum demand levels. The existing Walmart location at Maricopa-Casa Grande Highway and Porter Road provides that presence and there isn't any likelihood that an additional location in the region is warranted.

Grocery stores are an important anchor for local-serving retail shopping centers, drawing shoppers to the center and creating foot traffic for smaller retailers who occupy the inline shops. From a demand perspective, across the Greater Phoenix area, there are approximately 22,200 persons for every traditional grocery chain (Fry's, Safeway, Bashas' and Albertson's). When natural food stores (Whole Foods and Sprouts) and specialty stores such as AJ's and Trader Joe's are added to the total, the demand level declines to 18,400 persons per store. The ratio of persons per grocery store has been growing over the last 20 years due to increased competition from major chains such as Walmart, Target, and Costco, to name a few. This has resulted in consolidation in the grocery industry, the latest of which is the purchase of the Safeway chain by Albertson's.

At a population of just under 53,000 persons, the 7-mile Primary Market Area today can support between two and three grocery stores. Based on MAG forecasts, by 2030, one additional store could be supported. Additional population growth from 2030 through 2050 is enough to attract another grocery store.

When comparing these metrics to the Primary Market Area, there are already three grocery store options (Fry's, Bashas', and a Walmart Supercenter). There is also a Sprout's currently under construction which would be a fourth grocery store. Thus, the existing and future supply of grocery stores appears to satisfy much of the future demand for decades. One additional store location may be warranted over the next 10-20 years in the PMA.

The reasons for low level of retail development in 7-mile PMA include the following.



- At a current population of just under 53,000 persons, the region cannot support additional retailers who require a large population base. For instance, Walmart has 52 supercenters in Greater Phoenix for an average of 91,000 persons per store (and already present in the market area). Home Depot has 35 stores in Maricopa County and one store in Pinal County in Casa Grande which equates to one store for every 135,300 persons for the entire metro area. Other large format retailers such as Target and Lowe’s have similar persons per store ratios. Overall, the Primary Market Area is not large enough today to support additional significant large format, anchor retailers.
- Prior to the Great Recession, retailers were very aggressive in forward planning for store locations based on expectations of population growth. Greater Phoenix, with its tremendous history of rapid growth, is one region that historically has seen retailers anticipate where demand will develop and then enter the market in advance of that demand. The impact of the Great Recession, however, has resulted in the delay or cancellation of planned retail centers. Many of these planned centers have still not come to fruition. Retailers are also much more cautious today given the impact of online sales and slower population growth across the country.
- E-Commerce has had a significant impact on the development of brick-and-mortar retail centers. In 2021, E-Commerce accounted for 14.4% of all retail sales in the U.S., up from just 1.1% in 2001. Since 2010, E-Commerce has been growing at an average rate of 12.6% per year. The country has witnessed the loss of traditional shopping center retailers such as bookstores, shoe stores, sporting goods stores, toy stores, and florists. The consolidation of businesses has also occurred in many segments of the market (groceries, office supplies, electronics). As a result, retailers have become much more cautious in planning for new outlets unless there are significant signs of demand and/or population growth.

Based on the ratios of persons per retail store, we can conclude that the demand for retail services in the Primary Market Area is likely satisfied by the current level of retail development in the community, including developments currently under construction.

A second method of determining demand for commercial development is to evaluate the spending potential of the Primary Market Area population based on the U.S. Consumer Expenditure Survey (CES). The Survey is a long-term nationwide household survey conducted by the U.S. Bureau of Labor Statistics (BLS) to find out how Americans spend their money. It is the only federal government survey that provides information on the complete range of consumers’ expenditures as well as their incomes and demographic characteristics. The CES is used by



analysts to determine the demand for retail goods and services based on household income levels.

As noted previously, the 2021 median income of Primary Market Area residents ranges from \$46,371 to \$74,799 based on U.S. Census data. An economic model was prepared for this study to estimate the amount of retail and restaurant spending that may be derived from residents living in the Primary Market Area.

The following table outlines the spending that may be generated from the various rings within the Primary Market Area surrounding the subject site. Area residents would be expected to spend approximately 27%-36% of gross income or \$16,655 to \$20,316 per household on retail goods and services and restaurants, excluding spending on the purchase of a vehicle. Retail spending is then divided into two groups: local-serving retail spending and regional-serving retail spending. Local-serving spending includes groceries and other convenience goods and services (medical prescriptions, household supplies, tobacco products, and personal care products and services). Regional-serving spending is related to big-ticket items that typically are sold in large-format retail centers such as furniture, electronics, appliances, flooring, and apparel.

The following table shows that the typical Primary Market Area household is expected to spend an estimated \$7,651 to \$8,915 on local-serving retail items and \$6,298 to \$8,034 on regional-serving items. The remaining \$2,706 to \$3,367 is spent in restaurants and bars. Local-serving retail spending is then divided into grocery spending and non-grocery spending (household goods, day care, medical prescriptions and supplies, personal care products, etc.)

The lower part of the table converts the local-serving spending to potential retail square footage. For instance, grocery spending in the 7-mile Primary Market Area is estimated at \$77.9 million for the 17,804 households. At an average retail sales rate of \$500 per square foot for a supermarket, the Primary Market Area can support 155,900 square feet of grocery store space. However, within the 3-mile PMA, the existing 468 households can support just 3,635 square feet of grocery store space, well below the threshold for development.

Likewise, non-grocery, local retail spending of \$4,537 per household in the 7-mile radius generates demand for 269,250 square feet of additional retail space at \$300 per square foot retail sales. In the 3-mile radius, that figure is only 2,532 square feet.

Regional retail of 286,089 square feet can also be supported by the local population in the 7-mile radius. That figure drops to 5,895 square feet in the 3-mile radius.



Restaurant spending supports another 119,896 square feet of space in the 7-mile radius. In the 3-mile radius, that figure is only 2,532 square feet.

Together, an estimated 831,127 square feet of retail space can be supported in the 7-mile Primary Market Area based on the current population.

Retail Spending Analysis						
Papago Rd & Green Rd Rd Primary Market Area						
	3-mile		5-mile		7-mile	
Income & Spending Assumptions	Dollars	% of Income	Dollars	% of Income	Dollars	% of Income
Market Area Median Household Income 2021	\$46,371		\$65,590		\$74,799	
Total Retail Spending/HH (Excluding vehicles)	\$16,655	35.9%	\$19,130	29.2%	\$20,316	27.2%
Local-Serving Retail Spending	\$7,651	16.5%	\$8,506	13.0%	\$8,915	11.9%
Grocery Spending/HH	\$3,883	8.4%	\$4,218	6.4%	\$4,378	5.9%
Non-Grocery Local-Serving Retail Spending/HH	\$3,768	8.1%	\$4,288	6.5%	\$4,537	6.1%
Regional-Serving Retail Spending/HH	\$6,298	13.6%	\$7,472	11.4%	\$8,034	10.7%
Restaurant Spending/HH	\$2,706	5.8%	\$3,153	4.8%	\$3,367	4.5%
<hr/>						
2021 Population	1,431		17,079		52,992	
Households	468		5,534		17,804	
<hr/>						
	Retail Demand		Retail Demand		Retail Demand	
Supportable Local-Serving Retail Demand	Demand		Demand		Demand	
Total Grocery Spending	\$1,817,423		\$23,341,238		\$77,946,308	
Supportable SF at \$500 Per SF in Sales	3,635		46,682		155,893	
Non-Grocery Local-Serving Retail Spending	\$1,763,464		\$23,728,951		\$80,774,940	
Supportable SF at \$300 Per SF in Sales	5,878		79,097		269,250	
Restaurant Spending	\$1,266,192		\$17,447,548		\$59,947,807	
Supportable SF at \$500 Per SF in Sales	2,532		34,895		119,896	
Regional Serving Retail Spending	\$2,947,462		\$41,349,522		\$143,044,397	
Supportable SF at \$500 Per SF in Sales	5,895		82,699		286,089	
TOTAL LOCAL-SERVING RETAIL DEMAND	17,940		243,373		831,127	
<hr/>						
Sources: U.S. Consumer Expenditure Survey; AZ DOA; Elliott D. Pollack & Company						

Today, the total estimated retail space within the PMA is approximately 1.1 million square feet which exceeds the local demand within the 7-mile Primary Market Area. There are an additional 2,100 households in the City of Maricopa not within the 7-mile radius that also support retail space in the PMA. There is also a small amount of vacant retail space in the PMA, estimated at



approximately 41,844 square feet. Given the mix of local serving retail, restaurants, and regional serving retail currently present in the market area, it appears that the area is at equilibrium .

There is also retail development occurring in the PMA totaling nearly 141,795 square feet . Development under construction includes a Sprout’s, Marshalls, Petco, and approximately 70,000 square feet of available shops and pads for restaurants, shops, and space for consumer services such as banking, medical, dental, and insurance.

Future retail development will be heavily dependent on new residential growth in the area to spur new construction.

4.2 Retail Forecast

The most recent population forecast for the 7-mile Primary Market Area is for growth of 5,907 new households over the next ten years. In addition, the longer-term forecast anticipates 3,472 new households between 2030 and 2040 as well as 4,980 new households from 2040 to 2055. Total household growth over the next 35 years in the Primary Market Area is approximately 14,360 households.

Based on the above analysis, a 35-year forecast for retail demand was prepared for the Primary Market Area for the timeframe from 2020 to 2055. The forecast concludes that the demand for local and regional serving retail within the Primary Market Area will total approximately 96.2 acres, or 670,326 square feet of building space through 2055.

Retail Demand Forecast				
Papago Rd & Green Rd 7-mile Radius				
	2030	2040	2055	35-Year Total
Household Growth	5,907	3,472	4,980	14,359
New Retail Demand (SF)	275,769	162,103	232,455	670,326
New Retail Demand (acres)	39.6	23.3	33.4	96.2
Sources: MAG, 2019; U.S. Consumer Expenditure Survey; AZ DOR; Pinal County Assessor; City of Maricopa; Elliott D. Pollack & Company				



4.3 Supply

The supply of future available retail space can be found within existing retail or mixed-use developments as well as parcels of land currently planned for commercial uses. The following is a summary of available inventory located within the Primary Market Area.

There were seven existing retail developments identified in the Primary Market Area that have either vacant space, available pads, or both. Vacancy within these developments is as small as one shop totaling 1,200 square feet up to a significant amount of vacancy as a percent of the total center such as at John Wayne Parkway and Edison Avenue or along the Maricopa-Casa Grande Highway. Total vacant/available space among these developments is 41,844 square feet.

Commercial Real Estate Assets SEC Papago Rd & Green Rd PMA	
Existing Projects	Available SF
19756 N John Wayne Pky	2,900
20800 N John Wayne Pky	1,200
44500 W Edison Rd	2,981
21542 N John Wayne Pky	5,478
19590 N Maricopa Rd	2,760
41840 W Maricopa Casa Grande Hwy	14,490
44460 W Edison Rd	12,035
Total Available SF	41,844
Source: Elliott D. Pollack & Company; Town of Queen Creek; Maricopa Association of Governments; Maricopa County Assessor; Velocity Retail Group; Phoenix Commercial Advisors; Western Retail Advisors; Phoenix West Commercial; SRS Real Estate Partners; ZELL Commercial Real Estate Services; Cushman & Wakefield	

Through the course of this research, an estimated 392,775 square feet of retail space has been identified in the development pipeline within nine projects. Three projects, totaling 141,795 square feet are currently under construction at the corners of John Wayne Parkway and Edison Avenue as well as 18893 W Honeycutt Road. These projects include a Sprout's anchored neighborhood center and a Petco anchored development. The remaining developments have uncertain development timelines. If all are built, these projects will fill the region's retail needs for several years.



Retail Development Pipeline Papago Rd & Green Rd Primary Market Area				
Property Address	Property Name	Property Type	SF	Status
John Wayne Pky & Edison Ave	Sonoran Creek Marketplace	Community Center	102,072	Under Construction
18893 W Honeycutt Rd		Retail	19,723	Under Construction
44460 W Edison Rd		Retail	20,000	Under Renovation
41650 W Maricopa Casa Grande Hwy	The Wells	Retail	100,000	Proposed
SEC Hwy 347 & Edison St		Retail	2,500	Proposed
44500 W Edison Rd	Maricopa Marketplace II	Neighborhood Center	33,000	Proposed
NEC John Wayne Pky & Honeycutt Rd		Retail	10,480	Proposed
SEC Hwy 347 & Edison St		Retail	5,000	Proposed
NEC Edison Rd & John Wayne		Retail	100,000	Proposed
TOTAL			392,775	
Source: Elliott D. Pollack & Company; Thompson Thrift; CBRE; NAI Horizon; Commercial Properties, Inc.; Phoenix Commercial Advisors; Kidder Matthews; SRS Real Estate Partners; Newmark; Cushman & Wakefield				

Available Vacant Retail Land

In addition to existing centers with available space, 35 vacant retail parcels were located within the Primary Market Area, including the subject site. Combined, these vacant parcels total 912 acres. Utilizing a typical range of Floor Area Ratio (FAR) from .09 to .18, these parcels could accommodate over 6.7 million square feet of future retail or commercial development (under construction and proposed projects are included in this amount). Potential commercial development within the Ak Chin Indian Community is also not included in the total.

In total, there is nearly 6.8 million square feet of vacant space or land available for future retail development within the Primary Market Area.



Commercial Real Estate Assets SEC Papago Rd & Green Rd PMA	
Commercial Land Parcels	Acres
SEC Papago & Green	15
SWC Papago & Green	15
NEC Papago & Green	31.8
NWC Papago & Green	15
Porter Rd & Maricopa Hwy (The Wells)	35.2
NWC Farrell & White and Parker Rd	40.0
NEC Farrell Rd & Maricopa Hwy	31.0
SEC Farrell & White and Parker Rd	52
Bowlin & White & Parker Rd	27.0
SWC Edison Rd & John Wayne Pkwy	19
W of SWC Edison Rd & John Wayne Pkwy	15.8
Edison Pointe	1.5
SEC Hathaway & John Wayne Pkwy	5.4
SWC Porter & Smith Enke	3.0
NWC Porter & Smith Enke	3.5
Golden Hills Dr & Smith Rd	10.4
SWC Barnes Rd & White and Parker Rd	16.9
SEC Barnes Rd & White and Parker Rd	17.8
NWC Louis Johnson Dr & White and Parker Rd	41.6
SWC Louis Johnson Dr & White and Parker Rd	26.0
SWC Louis Johnson Dr & Smith Rd	11.1
Louis Johnson Dr & John Wayne Pkwy	47.7
SWC Louis Johnson Dr & Green Rd	13.5
SWC Louis Johnson Dr & Amarillo Valley Rd	14.2
SWC Barnes Rd & Amarillo Valley Rd	35.5
Teel Rd & John Wayne Pkwy	87.8
SWC Val Vista Rd & Ralston Rd	17.0
Hidden Valley Rd & Papago Rd	15.2
NWC Papago Rd & Amarillo Valley Rd	16.1
NWC Peters and Nail Rd & White and Parker Rd	15.2
NEC Peters and Nail Rd & Maricopa Hwy	24.4
Maricopa Hwy & Hartman Rd	38.0
NEC SR 238 & Green Rd	85.8
SEC SR 238 & Green Rd	36.6
NWC Bowlin Rd & John Wayne Pkwy	31.2
Total Acres	912.2
Gross SF	39,735,432
Yield SF (0.09-0.18 FAR)	6,738,100
Total Potential SF	6,779,944
Source: Elliott D. Pollack & Company; Town of Queen Creek; Maricopa Association of Governments; Maricopa County Assessor; Velocity Retail Group; Phoenix Commercial Advisors; Western Retail Advisors; Phoenix West Commercial; SRS Real Estate Partners; ZELL Commercial Real Estate Services; Cushman & Wakefield	



4.4 Site Comparison

The map below displays the supply of available commercial land in proximity to the subject site. As the map illustrates, there are numerous commercial sites located along John Wayne Parkway and Maricopa-Casa Grande Highway, as well as along SR 238 and White and Parker Road. Every one of these sites are competing with the subject site property to attract commercial development. Additionally, compared to expected demand, commercial land in the area is considered excessively oversupplied. Many of the sites will not be needed for commercial development.

Retail Supply Map – Primary Market Area

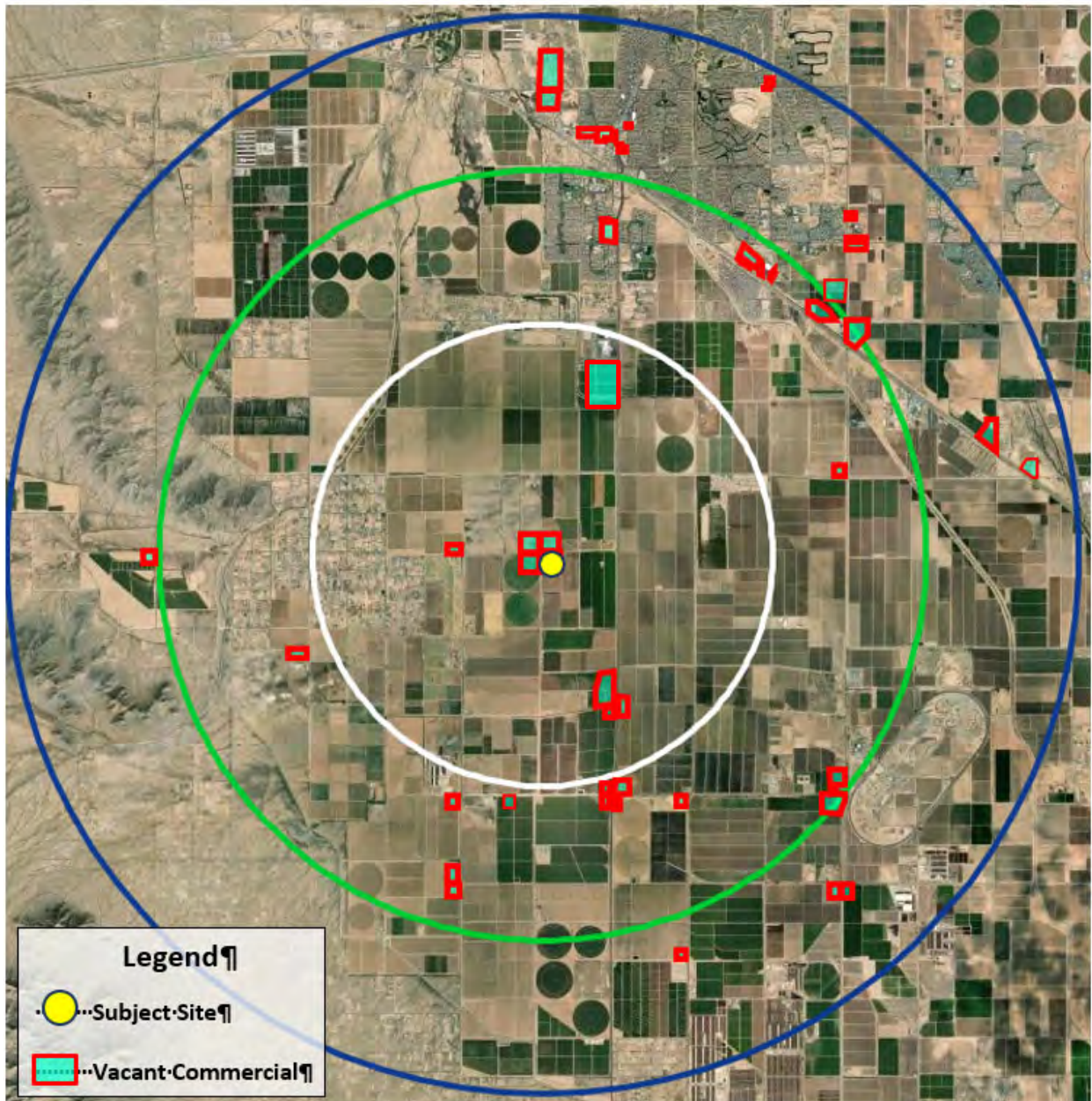

The subject site is at a disadvantage competitively with many of the alternative sites. First and foremost, retailers will prefer most of the sites located to the north closer to the city center, either in the area of Maricopa-Casa Grande Highway and Porter Road or along the SR 347 in the northern portion of the city. Residential developments in the southern area around the subject site would be considered part of their trade area and will make the drive to retail centers in the north. There is currently far too much risk to locate outside of the concentration of populated city boundaries. Also, with frontage along major roadways such as SR 238, SR 347, Porter Road, White and Parker Road, and Maricopa-Casa Grande Highway, these competing sites enjoy better visibility, and substantially higher traffic volumes.

In contrast, the subject site is located one mile west of SR 347 Highway (John Wayne Parkway), providing no highway frontage or visibility with the only frontage along Papago Road and Green Road.

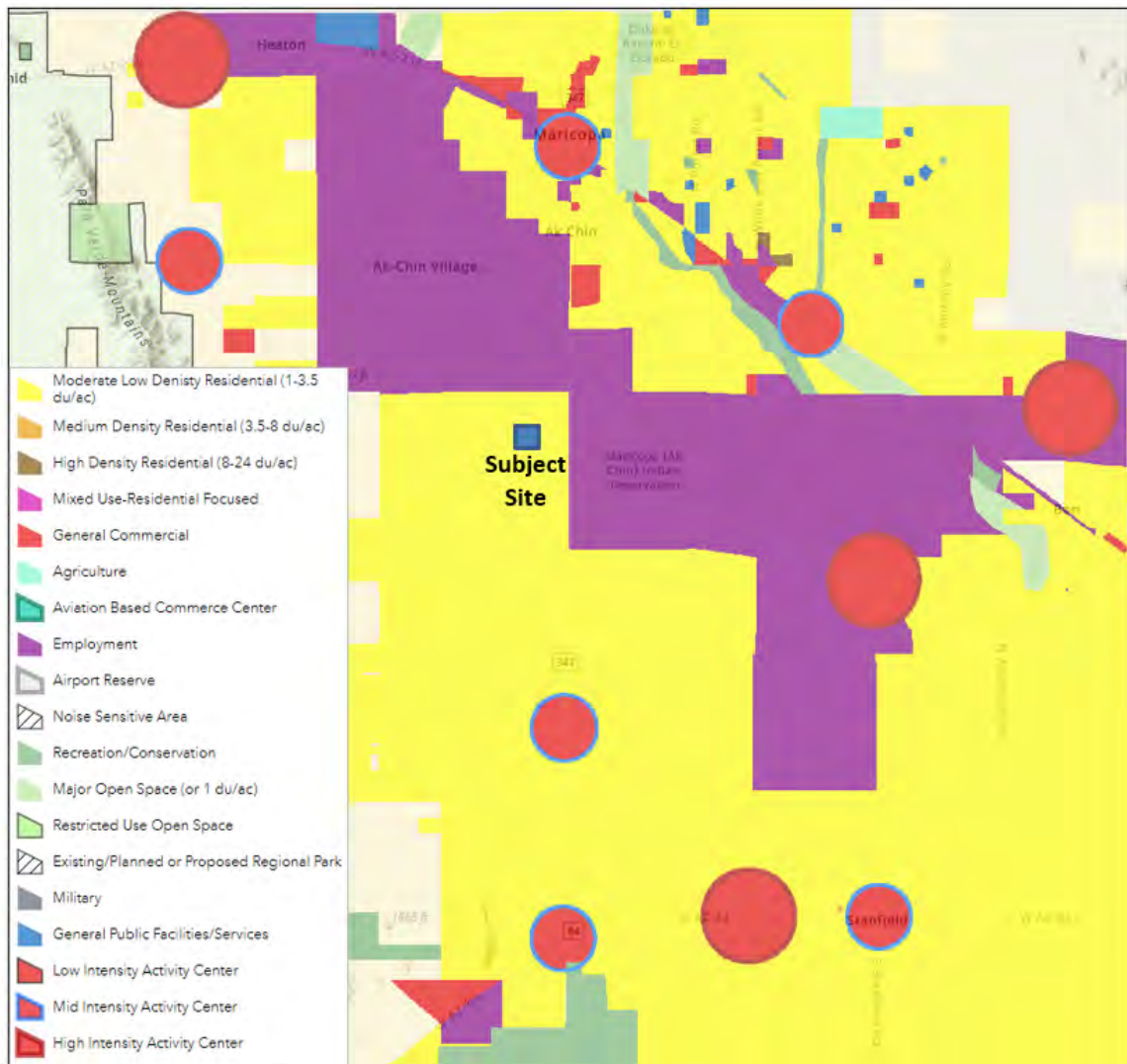

The subject site also has three competing sites in close proximity, all with significant frontage along Papago and Green Road and range in size from 15 to 32 acres. All four corners at the intersection of Papago Road and Green Road are designated for commercial or mixed use development. Clearly, there are too many sites for commercial development. This is especially true considering the extremely modest population base and relatively low level of future residential development expected in this southern area. Even when the subject site’s proposed developments and neighboring subdivisions build out, it will not be sufficient to trigger enough retail demand that the acreages offered on these parcels can accommodate.

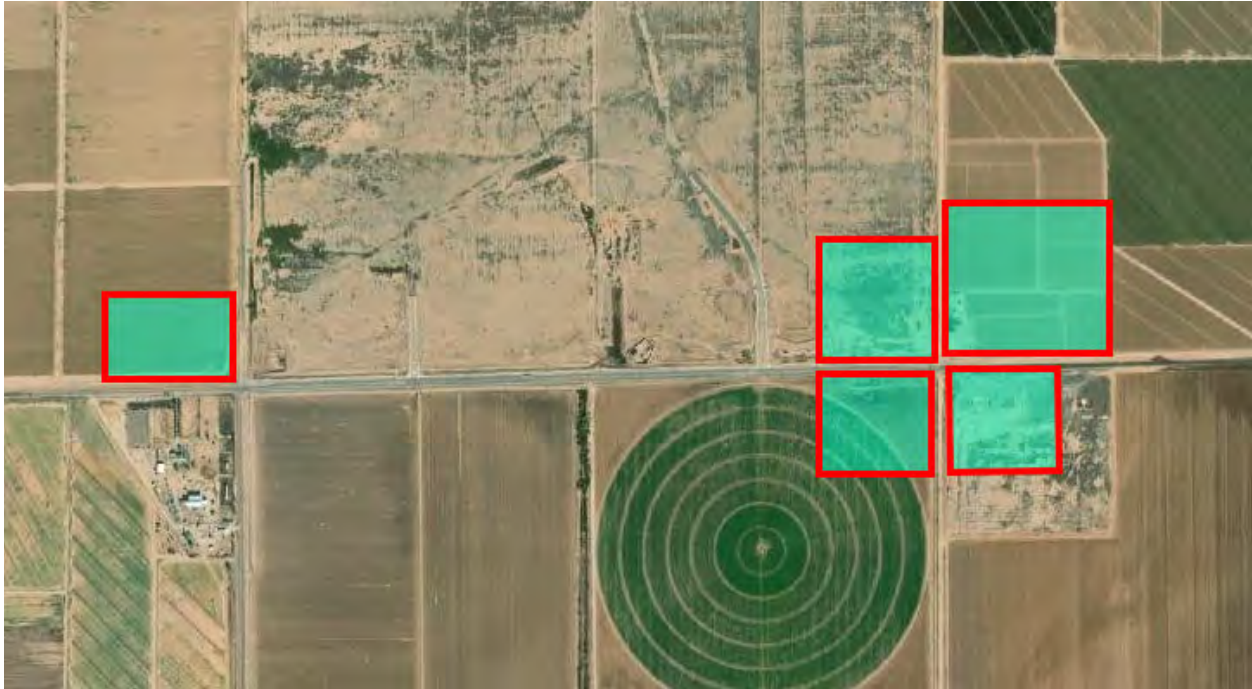

4.5 Summary

The forecasted retail demand of 670,326 square feet (gross land demand of 96.2 acres) is substantially lower than the estimated 6.8 million square feet of availability (combining 41,844 square feet of available space and land within existing centers and 912 acres of vacant commercial land) within the Primary Market Area. Compared to the available vacant space and available commercial land, there is far too much land in the Primary Market Area designated for future retail development. Potential commercial development within the Ak Chin Indian Community is also not included in the total.



Retail Supply/Demand Forecast				
Papago Rd & Green Rd 7-mile Radius				
	2030	2040	2055	35-Year Total
Household Growth	5,907	3,472	4,980	14,359
New Retail Demand (SF)	275,769	162,103	232,455	670,326
New Retail Demand (acres)	39.6	23.3	33.4	96.2
Supply (Available for Additional Retail Development)				
			<u>Acres</u>	<u>SF</u>
Existing Retail Centers				41,844
Vacant Land			912	6,738,100
TOTAL				6,779,944
Sources: MAG, 2019; U.S. Consumer Expenditure Survey; AZ DOR; Pinal County Assessor; City of Maricopa; Elliott D. Pollack & Company				

Even with more aggressive growth forecast scenarios, it is apparent that there is an oversupply of commercial land that is out of balance with future need. The area will never come close to needing the current amount of available commercial land.

Similar comments were recently echoed by the City of Maricopa. Based on their General Plan and the build out potential of the City's population, City staff estimated that there is over twice the amount of available commercial land that will be needed even after the City's population nearly triples in size.²

² <https://www.inmaricopa.com/catalyst-residential-growth-spurs-commercial-activity/>



5.0 Conclusions & Recommendations

- The retail marketplace has been significantly impacted by recent recessions (both the Great Recession and COVID-19), e-commerce and the rise of supercenters and warehouse clubs.
 - For the Greater Phoenix area, the Great Recession resulted in much slower population and employment growth and retailers have become much more cautious planning for new stores. Some ten years after the end of the recession, retail development has not returned to prior construction levels. This trend may continue for the foreseeable future, especially with the recent impacts of the COVID-19 pandemic and will impact properties currently designated for commercial development.
 - Virtually all retail sectors experienced substantial losses due to the COVID-19 pandemic, especially clothing, furniture, motor vehicles, sporting goods, department stores, and restaurants and bars. Non-essential purchases shifted substantially to e-commerce.
 - It remains to be seen whether or not the pandemic will permanently shift consumer behavior more heavily toward e-commerce. This could have material impacts on future commercial development and investment. Regardless, the shift toward online shopping will continue.
- The latest forecast for population growth in the Primary Market Area concludes that the demand for additional local serving retail land will total approximately 670,300 square feet or the equivalent of 96.2 acres over the next 35 years (through 2055). However, there is nearly 6.8 million square feet acres of available retail space and land (912 acres) within the Primary Market Area. Potential commercial development within the Ak Chin Indian Community is also not included in the total. There is far too much land in the Primary Market Area designated for future retail development compared to forecasted demand.
- There are at least 35 available commercial sites located within the subject site's primary market area. Every one of these sites are competing with the subject site property to attract retail development. The subject site is at a disadvantage competitively with many of the alternative sites. First and foremost, retailers will prefer most of the sites located to the north closer to the city center, either in the area of Maricopa-Casa Grande Highway and Porter Road or along the SR 347 in the northern portion of the city. Residential developments in the southern area around the subject site would be considered part of their trade area and will make the drive to retail centers in the north. There is currently far too much risk to locate outside of the concentration of populated city boundaries. Also, with frontage along major roadways such as SR 238, SR 347, Porter Road, White and Parker Road, and Maricopa-



Casa Grande Highway, these competing sites enjoy better visibility, and substantially higher traffic volumes. In contrast, the subject site is located one mile west of SR 347 Highway (John Wayne Parkway), providing no highway frontage or visibility with the only frontage along Papago Road and Green Road. The disadvantages compared to competing sites, combined with the fact that there is an excess of commercial land in the area, bodes poorly for the subject site's prospects to generate retail development interest.

- There are already sufficient neighborhood retail centers anchored by grocery stores for the market area's current and future population. A new Sprout's is currently under construction and the PMA will also see a new anchor pet supply store and surrounding shops and pads. A new grocery store may be justified with sufficient new population growth, but the subject site would not be a preferred site.
- The proposed residential developments, both at the subject site and on neighboring properties, will help to support existing retail assets within the Maricopa region. Each new additional resident will create demand for additional local serving retail and restaurants. Continued residential development in all forms within the market area will be critical to the eventual success of existing retail assets and additional commercial development. Local residents will be the main source of retail demand and also provide a local workforce for office development. This residential development must come first, eventually building to a critical mass of residents to attract additional retailers.
- In our opinion, the rezoning of the subject site to residential uses will not affect the area's efforts to continue to attract new commercial development to the community. The region has a significant inventory of commercial land that will provide for the long-term economic health of the community. Additionally, as a residential project, new residents will support existing and planned commercial development.





4550 N 12th Street
Phoenix, AZ 85014

Retail Market Analysis

Papago Rd & Green Rd Primary Market Area

Pinal County, Arizona



Prepared for:

LGI

March 2022

DRAFT
3/17/2022

Prepared by:



Elliott D. Pollack & Company
7505 East 6th Avenue, Suite 100
Scottsdale, Arizona 85251

Table of Contents

Executive Summary	i
1.0 Purpose of Study	1
1.1 Report Outline	1
1.2 Limiting Conditions	1
2.0 Retail Market Overview	3
2.1 Impacts of E-Commerce	5
2.2 Impacts of Superstores and Warehouse Clubs	6
2.3 COVID-19 Impacts	7
2.4 Greater Phoenix Retail Market	8
2.5 Maricopa Retail Market	10
3.0 Market Area Overview	12
3.1 Market Area Description	12
3.2 Population and Households	14
3.3 Forecasts	16
3.4 Summary	24
4.0 Retail Supply & Demand Analysis	25
4.1 Market Area Retail Demand	25
4.2 Retail Forecast	29
4.3 Supply	30
4.4 Site Comparison	33
4.5 Summary	35
5.0 Conclusions & Recommendations	37



Executive Summary

Elliott D. Pollack & Company was retained to conduct an economic analysis of a proposed rezoning of a vacant 15-acre parcel located on the southeast corner of Papago Road and Green Road in Pinal County, Arizona (located south of the City of Maricopa and the Ak Chin Indian Community) from commercial to residential uses. The scope of this engagement is to evaluate the various economic and real estate aspects of the proposed change and its impact on future retail development.

Findings & Conclusions

The retail marketplace has been significantly impacted by recent business cycles, e-commerce, and the rise of supercenters and warehouse clubs. Retailers have become much more cautious planning for new stores. Some ten years after the end of the Great Recession, retail development has not come close to returning to prior construction levels. This trend is likely to continue for the foreseeable future, especially with the recent impacts of the COVID-19 pandemic and will impact properties currently designated for commercial development.

The Maricopa region is essentially at equilibrium in terms of what the current population can support. The need for additional households to support more local serving retail development will be a guiding factor for Maricopa and the surrounding Primary Market Area (PMA).

The latest forecast for population growth in the PMA concludes that demand for additional retail land will total an additional 670,300 square feet, or the equivalent of 96.2 acres over the next 35 years (through 2055). Forecasted retail demand is substantially lower than the estimated 6.8 million square feet of availability (combining 41,800 square feet of available space within existing centers and 912 acres of vacant commercial land). Potential commercial development within the Ak Chin Indian Community is also not included in the total.

Retail Supply/Demand Forecast				
Papago Rd & Green Rd 7-mile Radius				
	2030	2040	2055	35-Year Total
Household Growth	5,907	3,472	4,980	14,359
New Retail Demand (SF)	275,769	162,103	232,455	670,326
New Retail Demand (acres)	39.6	23.3	33.4	96.2
Supply (Available for Additional Retail Development)				
			Acres	SF
Existing Retail Centers				41,844
Vacant Land			912	6,738,100
TOTAL				6,779,944
Sources: MAG, 2019; U.S. Consumer Expenditure Survey; AZ DOR; Pinal County Assessor; City of Maricopa; Elliott D. Pollack & Company				



Compared to the available vacant space and available commercial land, there is far too much land in the Primary Market Area designated for future retail development. Even with more aggressive growth forecast scenarios, it is apparent that there is an oversupply of commercial land that is out of balance with future need. The area will never come close to needing the current amount of available commercial land.

Similar comments were recently echoed by the City of Maricopa. Based on their General Plan and the build out potential of population, City staff estimated that there is over twice the amount of available commercial land needed even after the City’s population nearly triples in size.¹

New retail development within the PMA is also occurring, most notably at John Wayne Parkway and Edison Avenue, totaling nearly 141,795 square feet. Development under construction includes a Sprout’s, Marshalls, Petco, and approximately 70,000 square feet of available shops and pads for restaurants, shops, and space for consumer services such as banking, medical, dental, and insurance. In addition, there are five other planned retail developments in the PMA which would create 251,000 square feet of space. In total, there is an estimated 392,800 square feet of commercial space either under construction or planned in the PMA. If all are built, these projects will fill the region’s retail needs for several years.

Retail Development Pipeline Papago Rd & Green Rd Primary Market Area				
Property Address	Property Name	Property Type	SF	Status
John Wayne Pky & Edison Ave	Sonoran Creek Marketplace	Community Center	102,072	Under Construction
18893 W Honeycutt Rd		Retail	19,723	Under Construction
44460 W Edison Rd		Retail	20,000	Under Renovation
41650 W Maricopa Casa Grande Hwy	The Wells	Retail	100,000	Proposed
SEC Hwy 347 & Edison St		Retail	2,500	Proposed
44500 W Edison Rd	Maricopa Marketplace II	Neighborhood Center	33,000	Proposed
NEC John Wayne Pky & Honeycutt Rd		Retail	10,480	Proposed
SEC Hwy 347 & Edison St		Retail	5,000	Proposed
NEC Edison Rd & John Wayne		Retail	100,000	Proposed
TOTAL			392,775	
Source: Elliott D. Pollack & Company; Thompson Thrift; CBRE; NAI Horizon; Commercial Properties, Inc.; Phoenix Commercial Advisors; Kidder Matthews; SRS Real Estate Partners; Newmark; Cushman & Wakefield				

The map below displays the supply of available commercial land in proximity to the subject site. There are numerous commercial sites located along John Wayne Parkway and Maricopa-Casa Grande Highway, as well as along SR 238 and White and Parker Road. Every one of these sites are competing with the subject site property to attract commercial development. Additionally, compared to expected demand, commercial land in the area is considered excessively oversupplied. Many of the sites will not be needed for commercial development.

¹ <https://www.inmaricopa.com/catalyst-residential-growth-spurs-commercial-activity/>



Commercial Supply Map – Primary Market Area

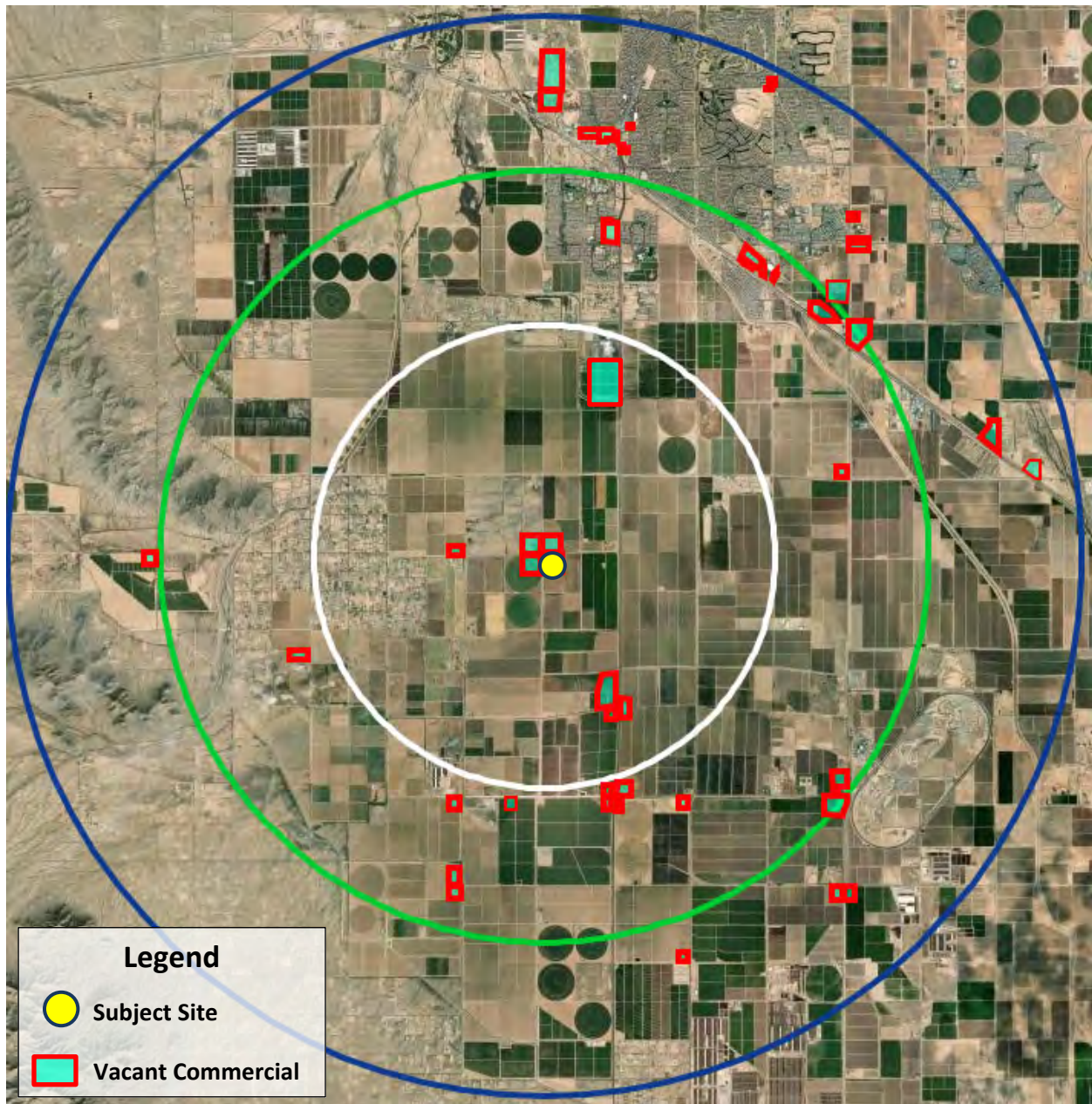

The subject site is at a disadvantage competitively with many of the alternative sites. First and foremost, retailers will prefer most of the sites located to the north that are closer to the city center, either in the area of Maricopa-Casa Grande Highway and Porter Road or along the SR 347 in the northern portion of the city. Residential developments in the southern area around the subject site would be considered part of their trade area and will make the drive to retail centers to the north. There is currently far too much risk to locate outside of the concentration of populated city boundaries. Also, with frontage along major roadways such as SR 238, SR 347,



Porter Road, White and Parker Road, and Maricopa-Casa Grande Highway, these competing sites enjoy better visibility and substantially higher traffic volumes. In contrast, the subject site is located one mile west of SR 347 Highway (John Wayne Parkway), providing no highway frontage or visibility with the only frontage along Papago Road and Green Road.

The Ak Chin Indian Community also sits to the area north of the subject site and south of the City of Maricopa. As the General Plan map and zoning map illustrate, Ak Chin Indian Community has designated a one-mile stretch of SR-347 frontage starting south of Farrell Road as Commercial. Frontage on the north half mile contains Harrah’s Ak Chin Casino and Hotel and the Ak Chin Circle Entertainment Center which includes movie theaters, bowling, arcade gaming, event facilities, outdoor amphitheater, and dining.

Ak Chin Indian Community also extends an additional one mile south down to Paters and Nall Road. Currently, the land use plan designates the east and west side of SR 347 as agriculture. However, the Community has shown that they are interested in continuing commercial development and could reclassify these areas for commercial uses as well.

Ak Chin Indian Community Land Use Map

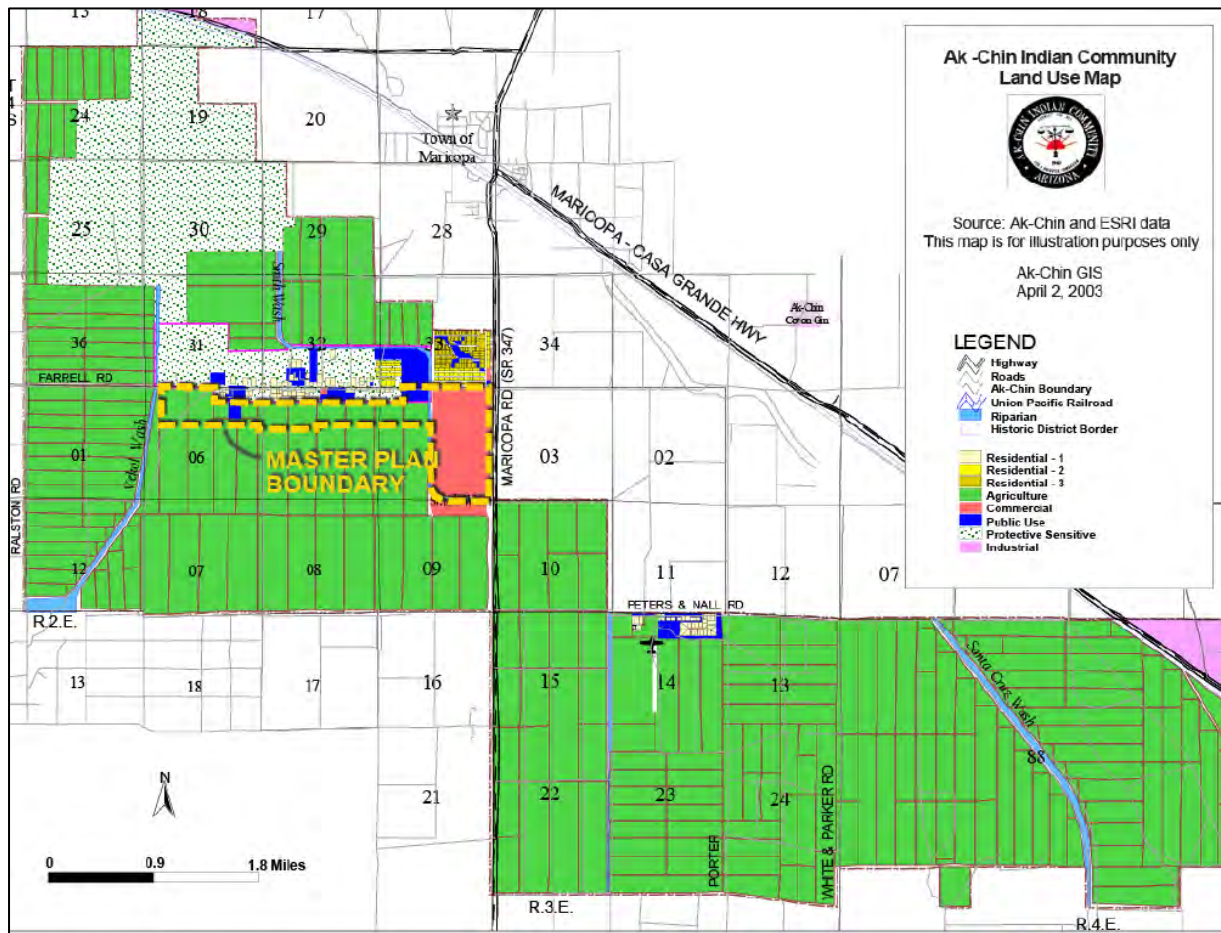

The proposed plan is compatible with the Pinal County Comprehensive Plan which denotes high intensity and medium intensity activity centers throughout the County which would be targeted for commercial and employment uses. The Comprehensive Plan chooses high traffic highways and arterials for these activity centers around the City of Maricopa, including SR 347, SR 84, and the Maricopa-Casa Grande Highway. The subject site is located in an area designated for moderate low density residential.

Pinal County Comprehensive Plan

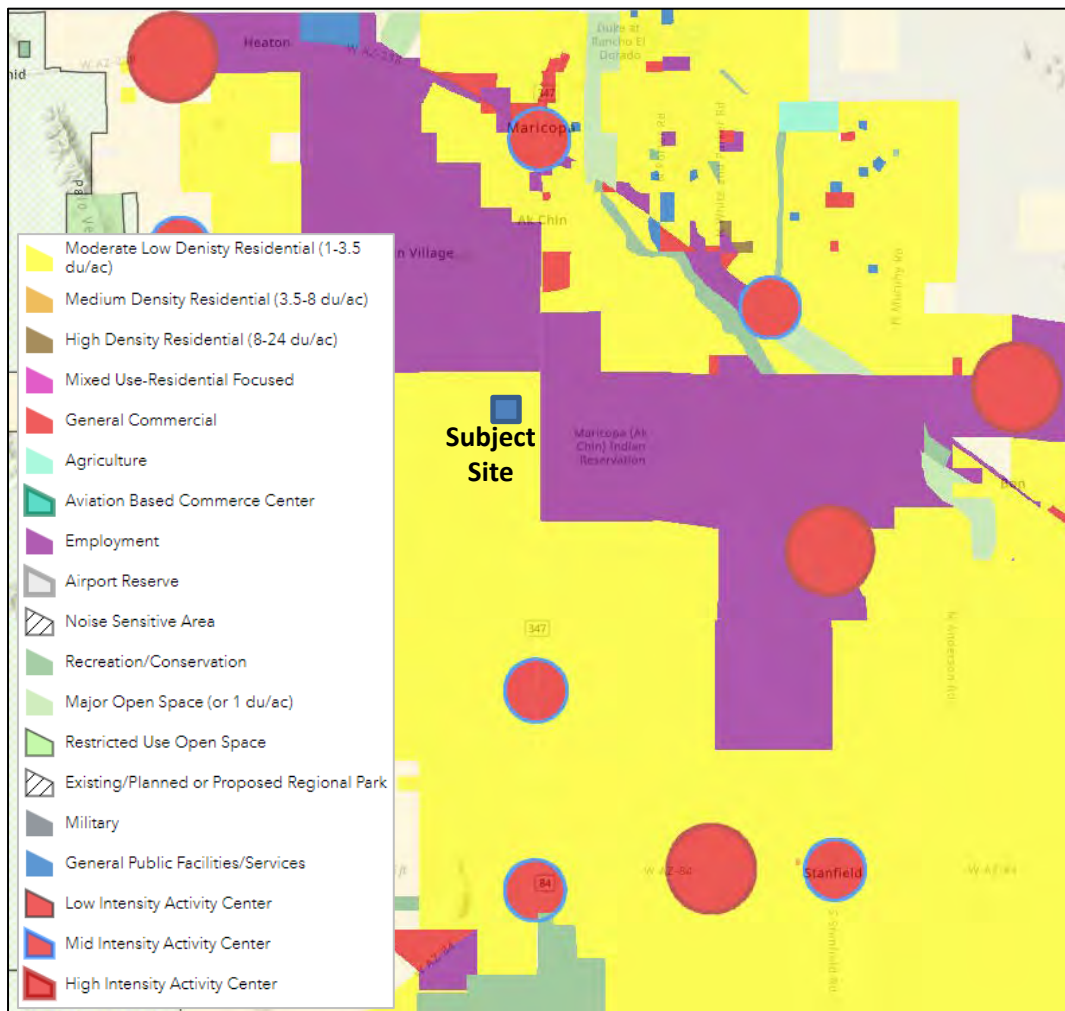

The subject site also has three competing sites in close proximity, all with significant frontage along Papago and Green Road and range in size from 15 to 32 acres. All four corners at the intersection of Papago Road and Green Road are designated for commercial or mixed-use development.

Clearly, there are too many sites for commercial development. This is especially true considering the extremely modest population base and relatively low level of future residential development



expected in this southern area. Even when the subject site’s proposed developments and neighboring subdivisions build out, it will not be sufficient to trigger enough retail demand that the acreages offered on the available parcels can accommodate.



The disadvantages to competing sites identified above, combined with the fact that there is an excess of commercial land in the area, bodes poorly for the subject site’s prospects to generate retail or other commercial development interest.

The proposed change to residential development will help support future retail assets within the PMA. Each new additional resident will create demand for additional local serving retail.

Continued residential development in all forms within the market area will be critical to the eventual success of existing retail assets and additional commercial development. As the following graphic helps to illustrate, local residents will be the main source of retail demand. This residential development must come first, eventually building to a critical mass of residents to attract additional retailers.

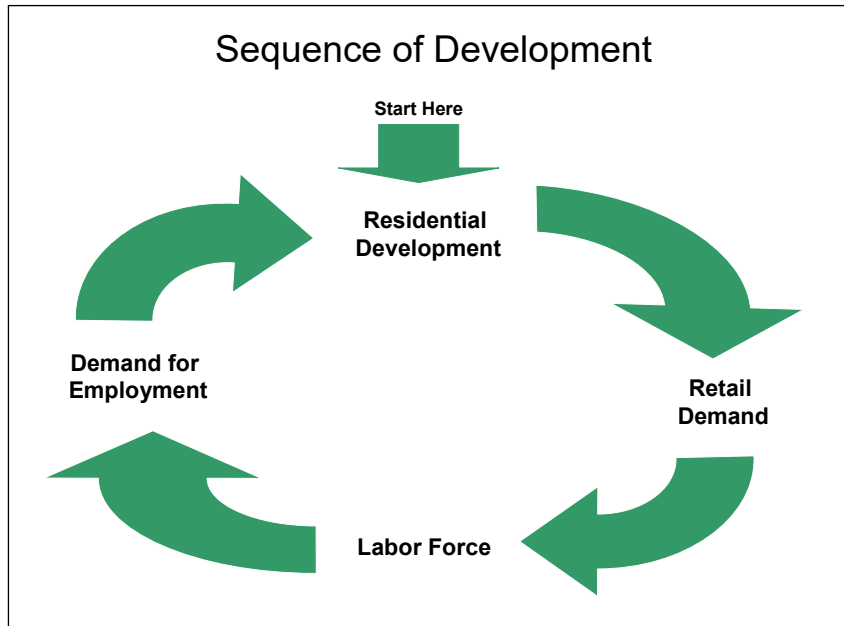

In our opinion, the rezoning of the subject site to residential uses will not affect the region's efforts to continue to attract new commercial development to the community. The area has a significant inventory of commercial land that will provide for the long-term economic health of the community. Additionally, as a residential project, new residents will support existing and planned commercial development. Overall, the proposed change for residential uses:

1. Is compatible for the site given its characteristics, neighboring developments, and location. It is also compatible with the Pinal County Comprehensive Plan.
2. Will accommodate new resident growth which will support existing and planned commercial development.
3. Will not harm the county's efforts to continue to attract new commercial development to this region of Pinal County based on available land compared to expected demand.
4. Recognizes that many alternative sites have competitive advantages over the subject site in terms of location, visibility, surrounding assets, and interest from retailers.



1.0 Purpose of Study

The purpose of this analysis is to determine the current and future demand for regional and local serving retail (including restaurants) in the market area surrounding the 15-acre subject site located at the southeast corner of Papago Road and Green Road. Our analysis will consist of evaluating the current size of the Primary Market Area, its potential development capacity, the supply of retail and available land, as well as the demand for commercial uses based on the surrounding market area population, the demographic characteristics of that population, and future growth.

1.1 Report Outline

Our study will consist of the following tasks.

1. Identification of the market area surrounding the subject site that would provide most of the demand for the project.
2. A summary of the demographic characteristics of the population in the market area.
3. Current and forecasted population growth estimates for the market area.
4. Supply of available retail space and land in the market area.
5. A forecast and summary of recommendations on the potential demand for commercial uses within the Primary Market Area based on market conditions.

1.2 Limiting Conditions

This study prepared by Elliott D. Pollack & Company is subject to the following considerations and limiting conditions.

- It is our understanding that this study is for the client's due diligence and other planning purposes.
- The reported recommendation(s) represent the considered judgment of Elliott D. Pollack and Company based on the facts, analyses and methodologies described in the report.
- Except as specifically stated to the contrary, this study does not give consideration to the following matters to the extent they exist: (i) matters of a legal nature, including issues of legal title and compliance with federal, state and local laws and ordinances; and (ii) environmental and engineering issues, and the costs associated with their correction. The user of this study will be responsible for making his/her own determination about the impact, if any, of these matters.



- This study is intended to be read and used as a whole and not in parts.
- Our analysis is based on currently available information and estimates and assumptions about long-term future development trends. Such estimates and assumptions are subject to uncertainty and variation. Accordingly, we do not represent them as results that will be achieved. Some assumptions inevitably will not materialize and unanticipated events and circumstances may occur; therefore, the actual results achieved may vary materially from the forecasted results. The assumptions disclosed in this analysis are those that are believed to be significant to the projections of future results.



2.0 Retail Market Overview

Market conditions existing today in the retail real estate sector have been severely affected by the growth of E-Commerce, the Great Recession, and most recently the economic shutdowns created by the COVID-19 pandemic. The last business cycle (2009-2020) exposed significant longer-term challenges for the brick-and-mortar retail market in Greater Phoenix and across the country. Compounding those issues, the COVID-19 pandemic suppressed local retail shopping in all but the most popular warehouse stores and grocers and shifted shopping patterns to online retailers. Future changes in shopping trends that will affect how the market performs over the long term. Following are some of those trends and challenges.

- **Domination:** The market has become dominated by big box retailers and power/community shopping centers.
- **Obsolescence:** Retailing is constantly changing resulting in some companies going out of business as others are entering the marketplace. Part of the problem for companies that are experiencing difficulties is the inability to anticipate trends in shopping patterns and the impact of alternative methods of purchasing goods and services. Currently, restaurants and value-oriented retail such as Walmart, Target, Ross, TJ Maxx, and others are the most viable in the market and actively expanding. The list of retailers and restaurants that are in bankruptcy or have been in bankruptcy is extensive and include:
 - Sears
 - Toys “R” Us
 - Sport Authority
 - Aeropostale
 - Beauty Brands
 - Shopko
 - Gymboree
 - Charlotte Russe
 - Payless Shoe Source
 - Diesel
 - Z Gallerie
 - Kona Grill
 - Perkins and Marie Callender’s
 - Barneys New York
 - Forever 21
 - Destination Maternity
 - Avenue
 - Pier One
 - Charming Charlie
 - FTD
 - David’s Bridal
 - Mattress Firm
 - Gump’s
 - Brookstone
 - Rockport
 - Nine West
 - Claire’s
 - Winn-Dixie
 - Bon-Ton
 - Rue21
 - BCBG Maxazria
 - Wet Seal
 - The Limited



The types of retailers that have experienced bankruptcies fall into a few categories. Bookstores long ago experienced significant declines in sales. More recently, clothing and accessory retailers, including shoe retailers, have experienced the most difficulties along with department stores and grocery chains. Department store sales have been declining for decades with the growth of low-cost supercenters and warehouse outlets. Grocery stores have come under attack from a wide range of retailers that have moved into the grocery business.

The traditional department store will continue to likely see declining sales. Macy's and Kohl's have reported sales slumps. JC Penney recently emerged from bankruptcy after being purchased by Simon Property Group (SPG) and Brookfield Asset Management.

- **Greater Phoenix is Over-Retailed:** Because of the Greater Phoenix region's tremendous history of growth, virtually all national retail chains want to be here, resulting in more retail space than is demanded by the population. According to the Lincoln Institute of Land Policy, the U.S. has 8.5 billion square feet of retail shopping center space or 24.5 square feet per person. By comparison, Maricopa County's population of more than 4.4 million has 34 square feet of retail space or 38% more than the national average. In the past, many national retail chains built stores in advance of growth to establish their market area. When growth slowed during the Great Recession, many planned stores were put on hold or abandoned. The coronavirus pandemic has further disrupted the growth of retail centers across the country and in Greater Phoenix.
- **Consolidation:** As retail market conditions change, consolidation of companies within the industry occurs. This trend has been particularly evident in the grocery store sector as chains try to compete with Walmart, Target and Costco. Local grocer Bashas' has been through bankruptcy and is likely still vulnerable.
- **Internet or E-Commerce Sales:** The long-term threat to brick-and-mortar retailing (and shifts from retail development to warehousing and distribution) is E-Commerce. Within the last 15 years, the market has seen seismic shifts in the manner in which people purchase retail goods and services. The COVID-19 pandemic has further pushed consumers towards internet-based purchases. Certain segments of the retail market have been particularly hard hit. A later section of this report will provide further information on the E-Commerce trend.

In summary, there are two major trends that have had a significant impact the retail market:

1. E-Commerce and
2. The rise of off-price retailers and low-price supercenters and warehouse outlets.



2.1 Impacts of E-Commerce

The U.S. Census defines E-commerce as “sales of goods and services where the buyer places an order, or the price and terms of the sale are negotiated, over an Internet, mobile device, extranet, Electronic Data Interchange (EDI) network, electronic mail, or other comparable online system. Payment may or may not be made online”.

The above definition technically excludes mail order sales from catalogs or other mail-order businesses. It does not include such businesses as mail-order book clubs. However, most catalog and book club purchases today are made over the internet and should properly be categorized as E-Commerce. For this study, mail order sales will be included in E-Commerce sales data.

Between 2000 and 2021, E-Commerce sales have grown by over eight-fold to \$947.6 billion, accounting for 14.4% of all retail sales in 2021. The coronavirus pandemic had a significant impact on retail sales patterns pushing normal in-store purchases to online. While only preliminary data for 2021 is available, the latest data from the U.S. Census shows that through December 2021 E-Commerce sales have increased by 6.6% over 2020. This follows an annual increase of 35.2% in 2020.

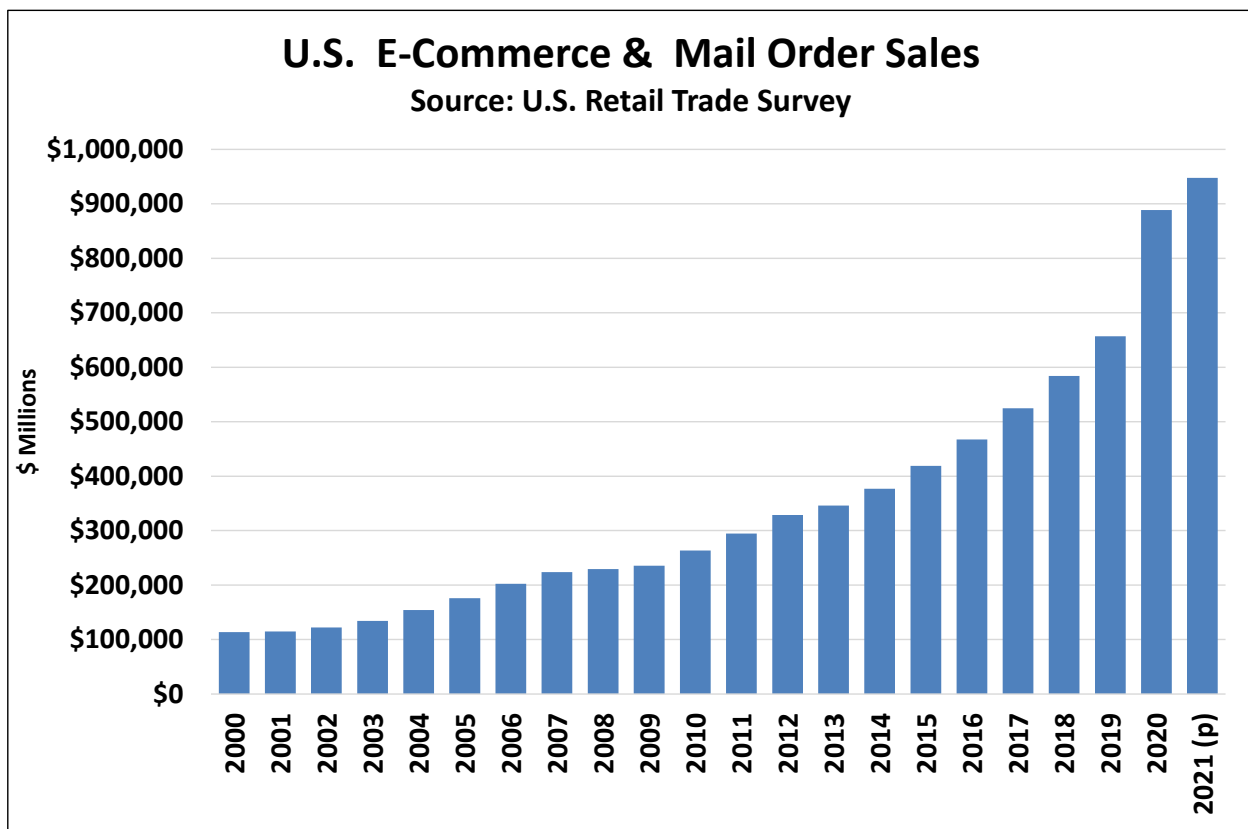

1.



Comparing preliminary 2021 data, E-Commerce sales comprised 14.4% of total sales. Due to the shutdown of the economy in March 2020 and peoples' desires to avoid crowds through the rest of the year, an above trendline portion of retail sales went to electronic shopping in 2020. While finalized data is not available for 2021, it appears that the number of COVID cases decreasing, and vaccination rate increases have brought a return to in-store shopping. However, even if 2020 represents an anomalous spike, 2021 saw continuation of growth and continued the upward trend of online sales.

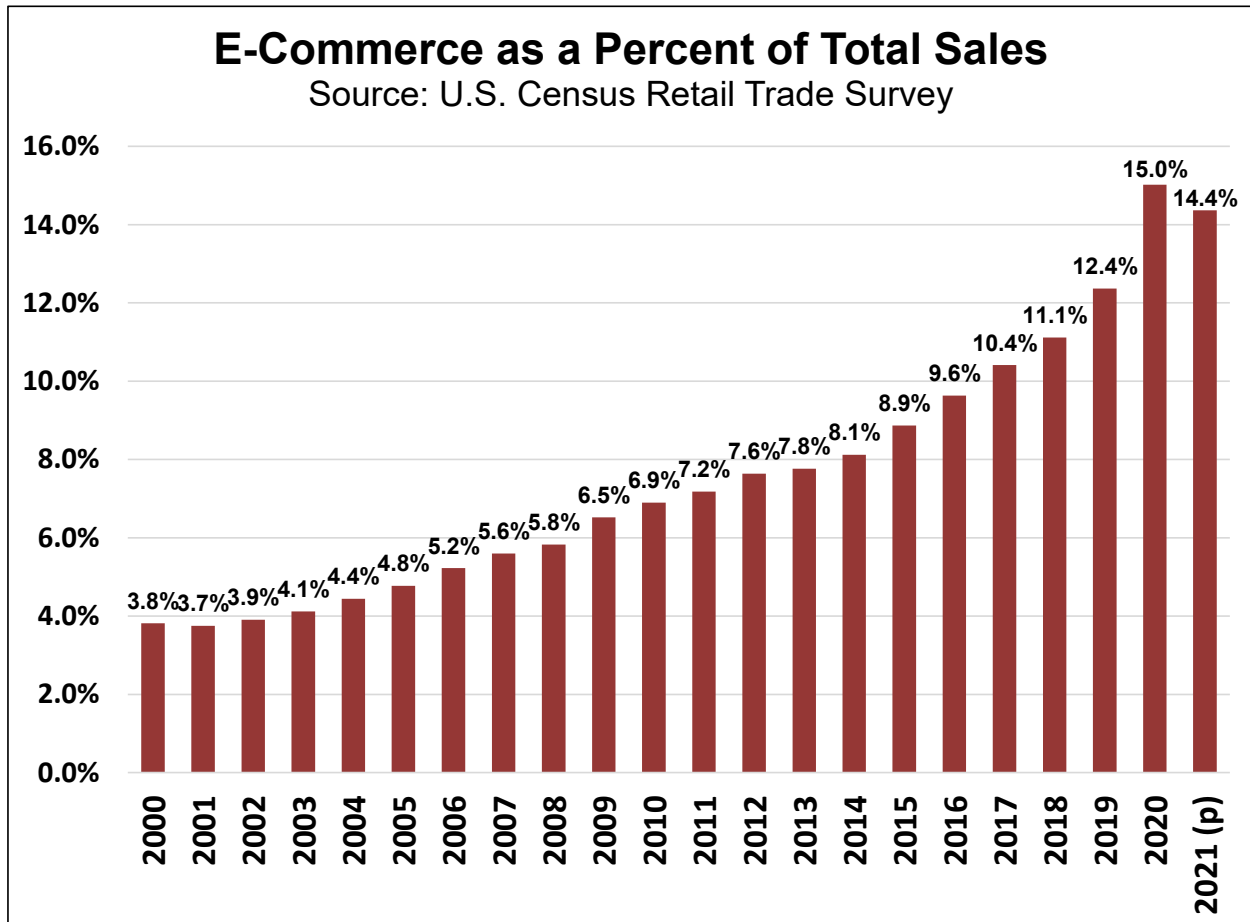

2.2 Impact of Superstores and Warehouse Clubs

In addition to the impact of E-Commerce on brick-and-mortar outlets, the expansion of superstores, such as Target and Walmart, and warehouse clubs, such as Costco, has resulted in a shift of retail spending from traditional department stores and small retailers. Off-price and value-oriented retailing has become the driving force in the retail sector. The following chart illustrates the shift in spending.



In 2000, spending at traditional department stores in the U.S. totaled more than \$96 billion. Today, that spending has declined to less than \$36 billion, resulting in the closure of many national and regional department store chains and bankruptcies such as Sears. By comparison, spending at supercenters and warehouse clubs ballooned from \$140 billion in 2000 to \$594 billion in 2021. Power centers anchored by Walmart, Target, Home Depot, Lowes and similar big-box retailers have become the primary outlets for retail sales.

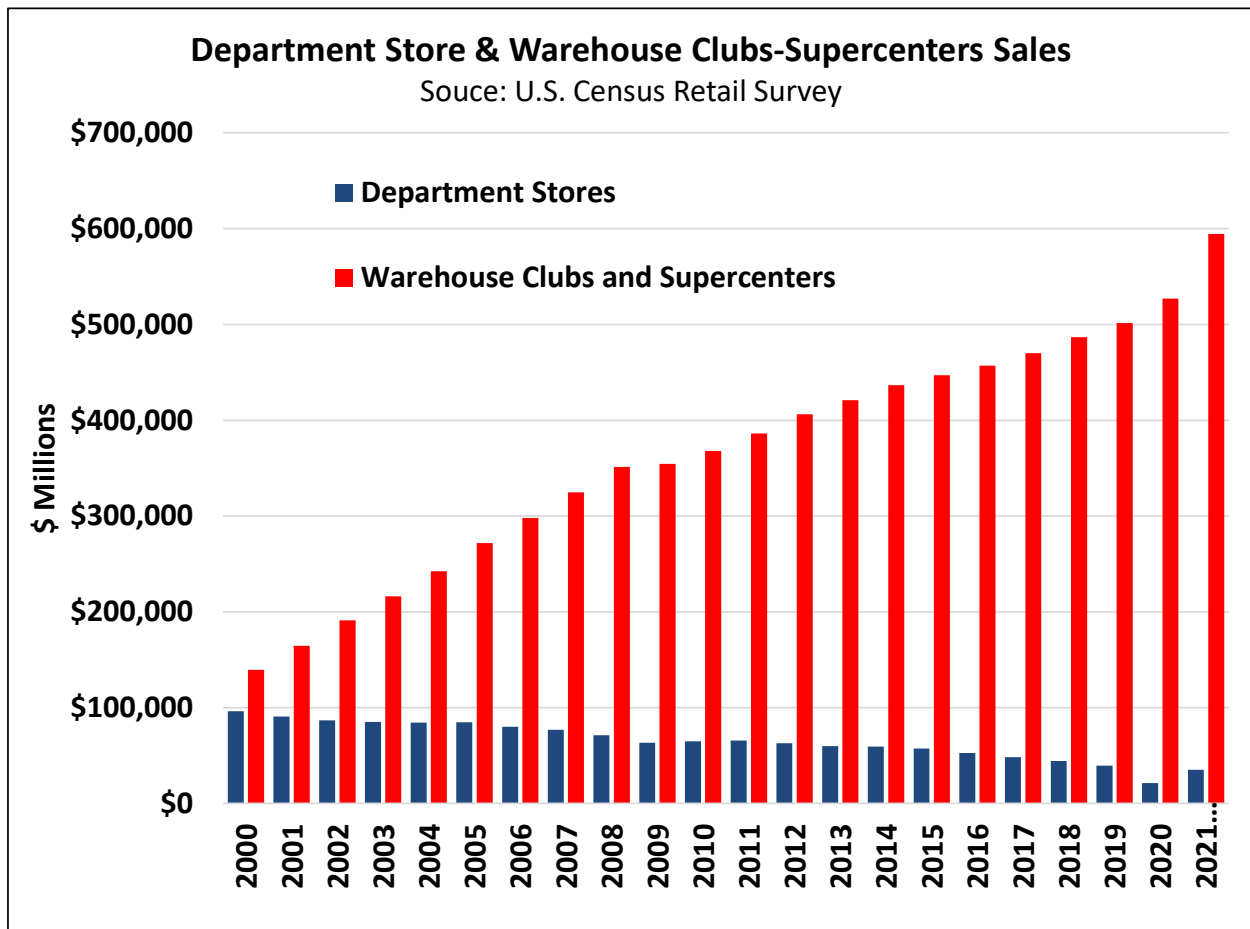

2.3 COVID-19 Impacts

The trend away from consumer spending in department stores has been occurring over the past 20 years and is likely now accelerated due to COVID-19. Retailers that have fared well during the pandemic include Walmart, Target, Home Depot, and a variety of grocery store chains. However, there were declines in sales at many other retailers. Restaurants and bars sustained significant reductions, as did fitness centers. The reopening of the economy has allowed these establishments to offset some losses, but some portion has been lost permanently.



The following chart provides some insight into retail sales patterns due to the pandemic. The data compares U.S. spending in April 2020 to April 2019. Virtually all retail sectors experienced substantial losses, especially clothing, furniture, motor vehicles, sporting goods, department stores, and restaurants and bars. Those that gained sales were building materials, groceries, and non-store retailers (E-Commerce). Even general merchandise stores, which includes Walmart, Costco, and Target, showed a loss of sales. Preliminary data shows these three retailers experienced growth in sales in April, but it was not enough to offset the losses of other general merchandise operators. Non-store retailers, primarily comprised of E-Commerce retailers, were the clear winners. The data shows the consumer's preferences for essential purchases while honoring stay-at-home recommendations. Non-essential purchases shifted to E-Commerce to avoid travel and congregating in crowds to socially distance.

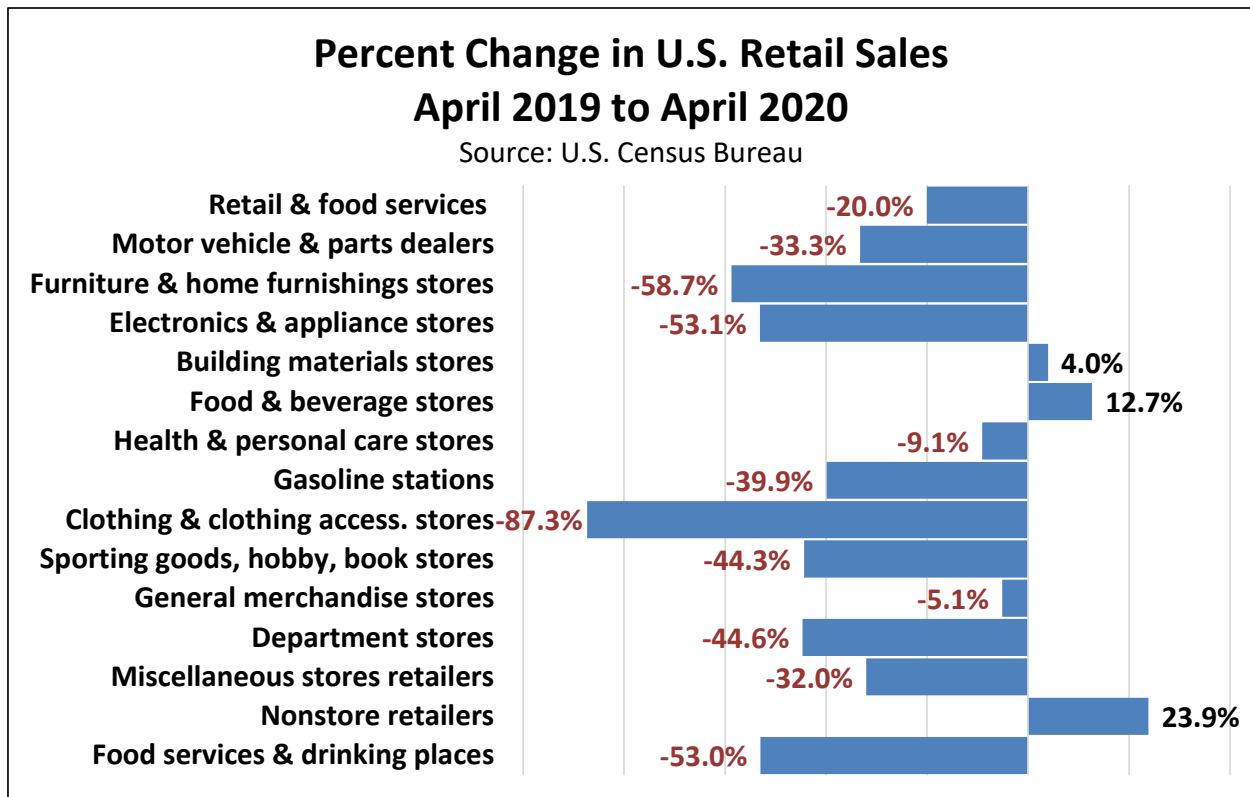

2.4 Greater Phoenix Retail Market

The Greater Phoenix retail market vacancy rate has experienced a gradual decline over the last decade from its previous peak of over 12% to 7.1% in the third quarter 2021. However, even with the tightening of the market, new construction activity remains disciplined. Construction activity is dominated by grocery-anchored projects with Sprouts, Fry's and Whole Foods as primary tenants. Power center development has largely been absent from the market.



Much of the absorption of space in Greater Phoenix over the past few years has been due to fitness and entertainment users backfilling vacant big-box and grocery store space. Since 2016, fitness users have absorbed 35 big-box spaces totaling over 1.0 million square feet. Due to demand for affordable fitness concepts, users like EoS Fitness, Planet Fitness, and LA Fitness are adding to their existing footprints. Newcomers include Crunch Fitness and VASA Fitness.

Even with the population and employment growth of Greater Phoenix area over the past two years, the retail market has not responded with significant construction activity. Greater Phoenix is in the top three metro areas in the country in job and population growth. Delivered retail space still is well below historic levels. Once again, E-Commerce and the popularity of supercenters and warehouse outlets is limiting extensive development of new retail space.

Since 2010, retail space delivered to the market has averaged 650,000 square feet annually or the equivalent of three to four neighborhood shopping centers each year. In 2020, only 286,300 square feet of retail space was delivered. Deliveries through the third quarter of 2021 total 301,890 square feet, well below the already modest 10-year average.

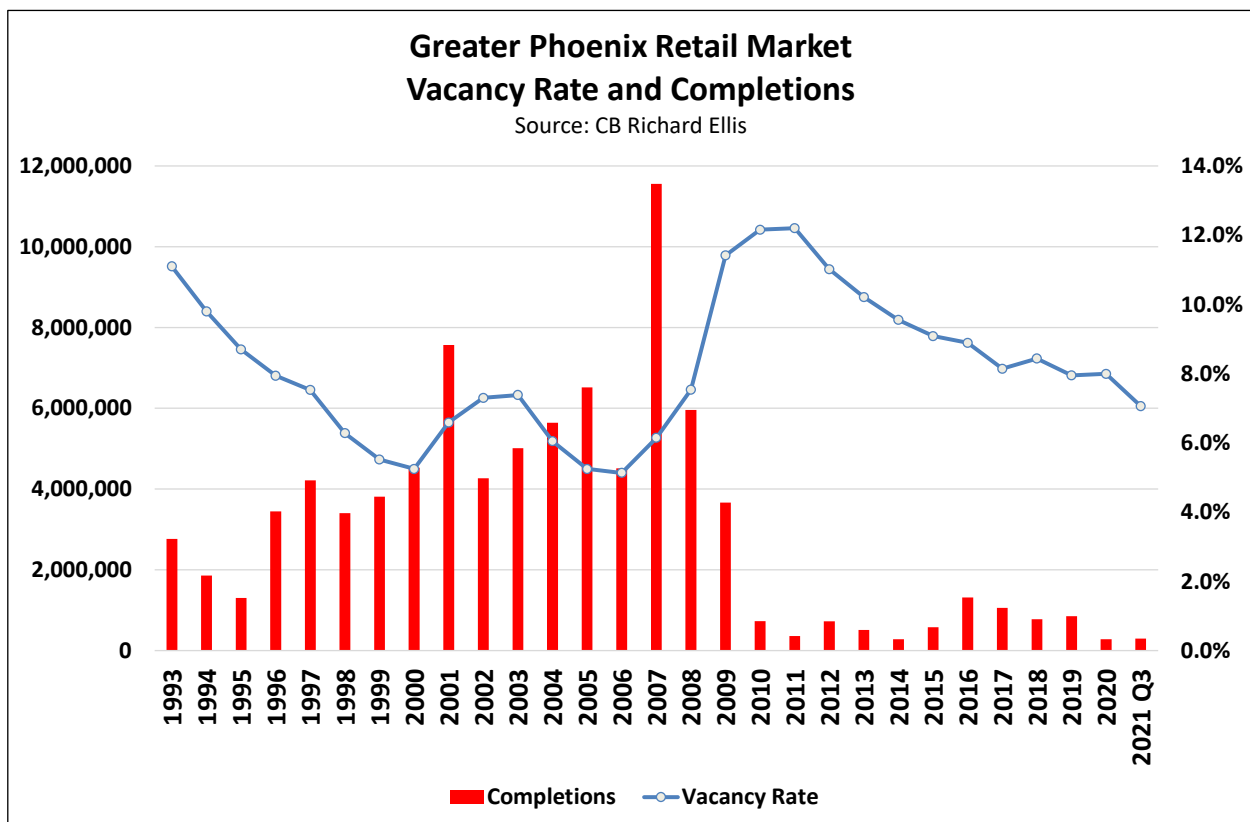

2.5 Maricopa Retail Market

The subject site is located south of the City of Maricopa and Ak Chin Indian Community in the West Pinal County submarket. Due to its location on the periphery of development in the Valley, trade areas for regional retailers are quite large. Locations in the City of Maricopa consider the residents of this area to be part of their customer base.

Maricopa has gradually cultivated a healthy mix of retail development, including a cluster of neighborhood shopping centers anchored by grocery stores and a Walmart Supercenter. There is approximately 1.1 million square feet of retail space and occupancy is strong, with only approximately 41,800 square feet of vacant space.

The range of types of retail outlets and merchandisers is still somewhat limited due to its population size but provides for many of the daily needs of residents, including many restaurants. A number of grocery retailers are located in the area, with a new Sprout's under construction at Edison and John Wayne Parkway. While many of these retail locations are located some distance from the subject site, they are still within a reasonable drive and on the typical commuting route for many area residents.

An aerial photo of the primary anchor tenants in relation to the subject site's Primary Market Area is provided below.



Major Retailers – City of Maricopa



3.0 Market Area Overview

3.1 Market Area Description

The Primary Market Area (PMA) is defined as the geographic area from which demand for a particular real estate product will arise. It is also the area containing similar and, therefore, directly competitive real estate projects. For this analysis, the focus of the primary market area surrounding the subject site is for local-serving, neighborhood retail development. For purposes of this report, the competitive market area will be called the Primary Market Area (PMA).

When conducting a market study, one of the most important steps is defining the project's primary trade, or market area. The first step in evaluating an appropriate market area is to analyze the characteristics of the neighborhoods immediately adjacent to the subject property. Typically, the market area includes the property three to five miles from the subject site, adjusted for the real estate product (in this case local serving retail such as grocery, personal and household services, restaurants, etc.), geographic features, socioeconomic conditions or economic circumstances.

It is common to utilize major freeways, or roads near major freeways, as market area borders since they often define neighborhoods within which people reside, shop and recreate. People become accustomed to residing in a particular part of the metro area and often do not stray far from those areas when relocating their place of residence. Natural topographic features are also a factor that affects people's living preferences and habits.

Based on analysis of the geographic features of the area and the layout of census tracts, existing neighborhood retail assets, preferable drive time for neighborhood retail, interviews with developers and economic development experts, as well as the experience of this firm in conducting market studies for neighborhood retail developments, a range of three to seven miles was used to evaluate the strength of the subject site for retail development. The three- and five-mile radius from the subject site that would be considered a typical Primary Market Area contained very little retail inventory and existing population. It was important to capture additional market data in a seven-mile radius to more fully capture the City of Maricopa region.

The PMA range for the subject site recognizes both the transportation network and the substantial competition to the north and the likely preference of residents north of the subject site to prefer those locations in Maricopa based on access while residents to the south have relatively fewer options and may consider visiting the site as a retail option.



Primary Market Area

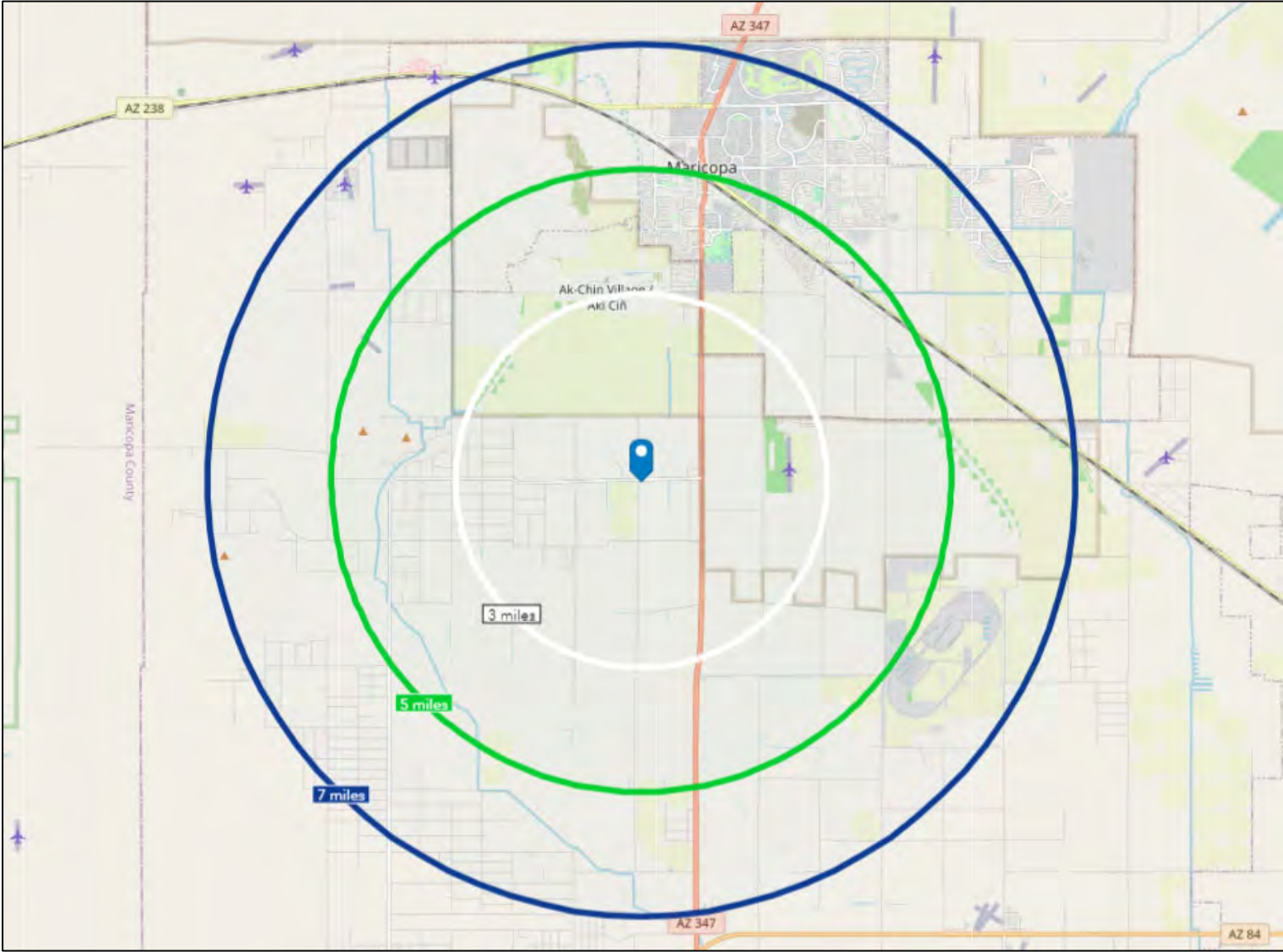

As discussed previously, the defined primary market area is specific to the subject site as the most likely draw by residents. Residents likely spend a portion of their disposable income for local-serving goods outside of these PMA boundaries, but the PMA represents the subject site's most likely area to draw customers from.

3.2 Population & Households

The following table shows the estimated population of the 3-, 5-, and 7-mile rings around the subject site as well as Pinal County for reference. The City of Maricopa in the northern area of the PMA and Pinal County both experienced substantial growth from 2000 to 2010, growing by an average annual rate of 21.8% and 7.7%, respectively. In the subsequent decade from 2010 to 2021, the 7-mile PMA has maintained an average growth rate of 2.6% per year compared to 2.1% in the county. There are an estimated 2.98 persons per household within the 7-mile Primary Market Area.

The 3-mile radius surrounding the subject site is far less populated and has not experienced much growth over the last two decades. This area has seen growth of only 124 households, capturing just 0.8% of growth in the region from 2000 through 2021.

Population Estimates								
	3-Mile		5-Mile		7-Mile		Pinal County	
	Persons	Annual Percent Growth	Persons	Annual Percent Growth	Persons	Annual Percent Growth	Persons	Annual Percent Growth
2000	1,056		3,025		5,559		179,727	
2010	1,278	1.9%	14,144	16.7%	39,829	21.8%	375,770	7.7%
2021	1,431	1.0%	17,079	1.7%	52,992	2.6%	469,799	2.1%

Source: ESRI Business Analyst, U.S. Census Bureau, Census 2010, Esri forecasts for 2021 and 2026.

Income

Median incomes are typically used to judge the well-being of a geographic area since they represent the mid-point of the range of incomes. It will also be utilized in terms of the PMA's ability to support retail development.

Household incomes in the main City of Maricopa area are quite higher than Pinal County averages. Both median income and average incomes are higher in the 7-mile PMA. Median income in the 7-mile PMA is an estimated \$74,799 per household versus \$60,923 across Pinal



County. This data indicates there is above average spending power due to above average disposable incomes among current residents. The 3-mile radius contains much more modest incomes, with a median household income of \$46,371.

Household Income - 2021				
	3-mile	5-mile	7-mile	Pinal County
Total households	468	5,534	17,804	158,790
Less than \$15,000	9.2%	5.5%	5.0%	7.6%
\$15,000 to \$24,999	10.0%	5.5%	4.5%	8.0%
\$25,000 to \$34,999	15.0%	7.4%	6.7%	8.0%
\$35,000 to \$49,999	19.2%	15.3%	12.5%	14.5%
\$50,000 to \$74,999	18.8%	22.8%	21.4%	21.8%
\$75,000 to \$99,999	6.2%	14.8%	16.5%	14.9%
\$100,000 to \$149,999	10.3%	19.0%	21.0%	15.9%
\$150,000 to \$199,999	11.1%	6.9%	8.1%	5.5%
\$200,000 or more	0.0%	2.8%	4.2%	3.7%
Median Income	\$46,371	\$65,590	\$74,799	\$60,923
Avg Income	\$63,307	\$79,912	\$88,021	\$77,597

Source: ESRI Business Analyst, U.S. Census Bureau, Census 2010, Esri forecasts for 2021 and 2026.

Age

The average age of PMA residents ranges from 31.5 to 36.3 years compared to 37.2 for Pinal County. The age demographics are consistent with the incomes found in the area.

Population by Age - 2021								
	3-mile		5-mile		7-mile		Pinal County	
Under 5 years	102	7.1%	1,623	9.5%	4,716	8.9%	34,295	7.3%
5 to 9 years	99	6.9%	1,605	9.4%	4,769	9.0%	34,295	7.3%
10 to 14 years	92	6.4%	1,469	8.6%	4,345	8.2%	32,416	6.9%
15 to 24 years	197	13.8%	2,203	12.9%	6,147	11.6%	54,966	11.7%
25 to 34 years	207	14.5%	2,494	14.6%	7,366	13.9%	64,362	13.7%
35 to 44 years	156	10.9%	2,835	16.6%	8,638	16.3%	64,362	13.7%
45 to 54 years	152	10.6%	1,913	11.2%	5,829	11.0%	50,268	10.7%
55 to 64 years	195	13.6%	1,435	8.4%	4,981	9.4%	51,208	10.9%
65 to 74 years	162	11.3%	1,042	6.1%	4,345	8.2%	51,678	11.0%
75 to 84 years	62	4.3%	393	2.3%	1,537	2.9%	25,369	5.4%
85 years and over	9	0.6%	51	0.3%	265	0.5%	6,107	1.3%
TOTAL	1,431		17,079		52,992		469,799	
Median Age	36.3		31.5		33.9		37.2	

Source: ESRI Business Analyst, U.S. Census Bureau, Census 2010, Esri forecasts for 2021 and 2026.



Educational Attainment

Educational attainment among the residents of the 7-mile Primary Market Area outperforms County averages. There is a higher level of college-educated residents, including those with some college experience, associate's degrees, and bachelor's degrees compared to the County and lower rates of residents with no high school diploma. The PMA also has a higher percentage of residents with a graduate or professional compared to Pinal County. The smaller 3-mile area contains lower educational attainment compared to the broader area and Pinal County, with higher rates of individuals without a high school diploma and generally lower rates of college attendance, though associate's degrees are higher. This is again consistent with household income results.

Educational Attainment								
Highest Educational Level	3-mile		5-mile		7-mile		Pinal County	
	Persons	%	Persons	%	Persons	%	Persons	%
Population 25 years and over	944		10,174		32,986		313,846	
Less than 9th grade	111	11.8%	356	3.5%	1,122	3.4%	14,751	4.7%
9th to 12th grade, no diploma	157	16.6%	916	9.0%	2,111	6.4%	27,932	8.9%
High school graduate/GED	260	27.5%	3,134	30.8%	9,302	28.2%	91,015	29.0%
Some college, no degree	219	23.2%	2,788	27.4%	9,104	27.6%	86,308	27.5%
Associate's degree	103	10.9%	1,068	10.5%	3,727	11.3%	29,815	9.5%
Bachelor's degree	87	9.2%	1,262	12.4%	4,915	14.9%	42,369	13.5%
Graduate or professional degree	8	0.8%	651	6.4%	2,672	8.1%	21,655	6.9%

Source: ESRI Business Analyst, U.S. Census Bureau, Census 2010, Esri forecasts for 2021 and 2026.

3.3 Forecasts

Forecasts for the Primary Market Area from the Maricopa Association of Governments (MAG) are shown on the following table. The entire 7-mile Primary Market Area population is expected to grow by 17,595 persons over the next ten years (5,904 new households). The decade following between 2030 and 2040 is expected to bring an additional 10,343 residents (3,471 new households). From 2040 to 2050 the 7-mile Primary Market Area is expected to increase by 9,747 residents (3,271 new households).

The 3-mile radius surrounding the subject site is projected to grow modestly compared to Maricopa as a whole. This southern region is projected to capture just 8.9% of total growth.



The area between three and five miles is expected to capture an estimated 18.1% of projected growth. The largest growth area is expected to occur between five and seven miles from the subject site to the north, projected to capture 73% of total growth. This is consistent with current growth patterns and commercial development locating in proximity to the population base.

Employment in the market area is anticipated to grow 4.4% per year from 2020 to 2030 which would add 3,117 new employees to the area. Jobs are expected to increase by another 3,879 over the following decade (2030-2040) and by an additional 6,270 jobs from 2040 to 2050. The northern area of the PMA is again expected to capture the majority of employment growth.

Forecasts					
Population & Employment					
	2020	2030	2040	2050	2055
3-mile					
Household Population	1,364	2,029	3,499	4,644	5,262
Households	447	665	1,147	1,523	1,725
Growth		218	482	375	203
Jobs	1,134	1,281	1,740	2,580	3,072
5-mile					
Household Population	23,525	27,289	30,508	33,501	35,470
Households	7,638	8,860	9,905	10,877	11,516
Growth		1,222	1,045	972	639
Jobs	3,237	4,551	6,527	8,931	10,375
7-mile					
Household Population	62,792	80,387	90,730	100,477	105,563
Households	21,071	26,976	30,446	33,717	35,424
Growth		5,904	3,471	3,271	1,707
Jobs	5,747	8,864	12,743	19,013	22,036
Source: Maricopa Association of Governments Socioeconomic Projections, 2019					

Within the PMA, areas in the northern portion have the highest concentration of active subdivisions. This includes several master planned developments and subdivisions including Tortosa, Rancho El Dorado, Rancho Mirage Estates, Homestead, Palo Brea, and Santa Rosa Crossing.



Permits in 2020 totaled 1,514 homes. In 2021, permits have totaled 1,801 homes. However, there are only 1,522 available lots remaining in active subdivisions. Future subdivisions (subdivisions that are platted but have not had a permit issued) that were identified in the PMA would provide an additional 2,942 lots for a total of 4,464 new homes.

For perspective, the following map illustrates currently active new home subdivisions within the PMA. As the map illustrates, many of the currently active new home subdivisions are located in the north.

Active New Home Subdivisions

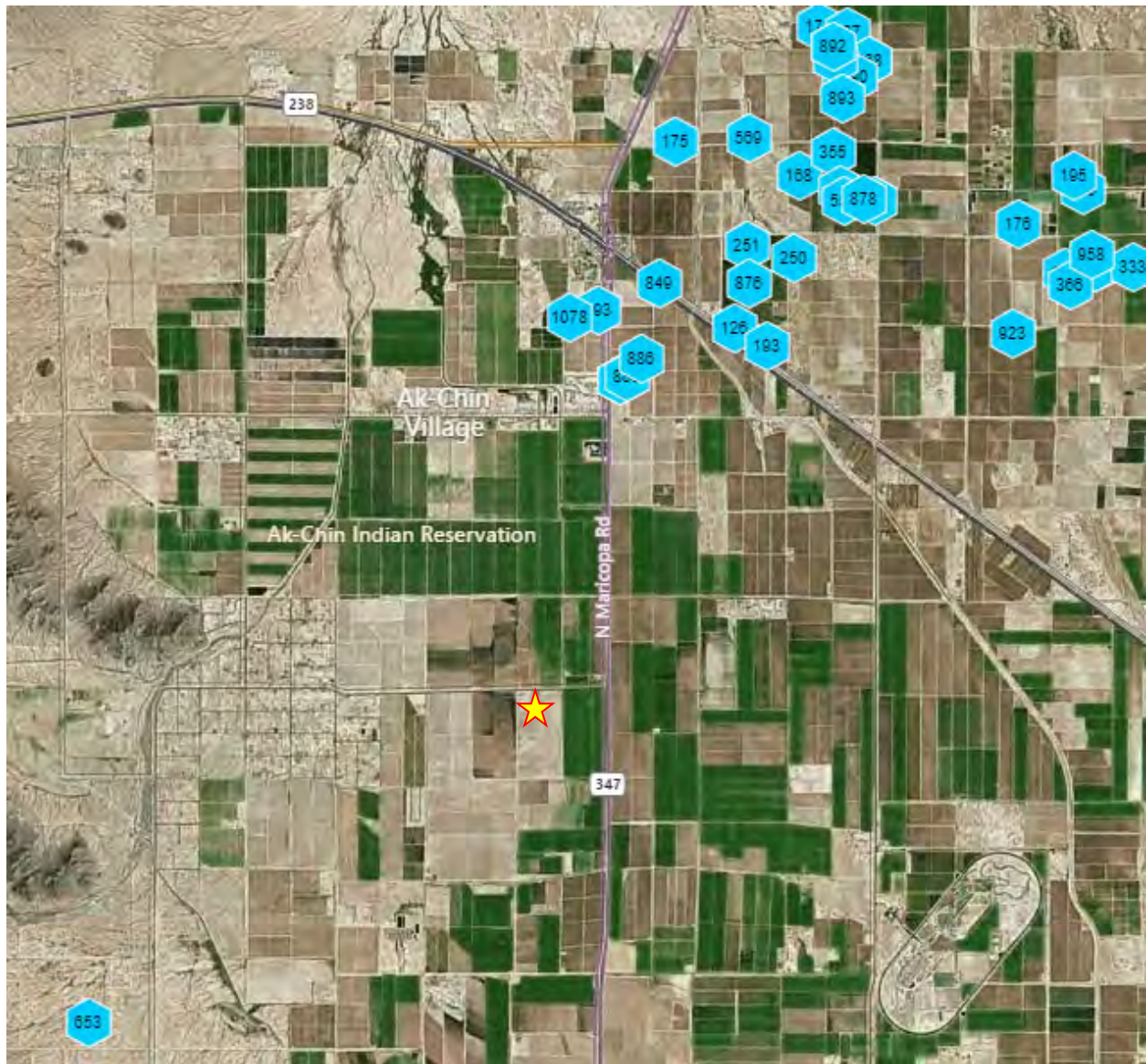

Source: RL Brown



There are also several planned multifamily developments within Maricopa totaling approximately 2,313 units. These projects are also located well north of the subject site in the heart of the City of Maricopa, stretching from Smith Enke Road down to Bowlin Road, approximately four miles north of the subject site.

Existing land uses surrounding the subject site are largely agricultural uses, with substantial residential and commercial development occurring north of the Maricopa-Casa Grande Highway.

Existing Land Use Map

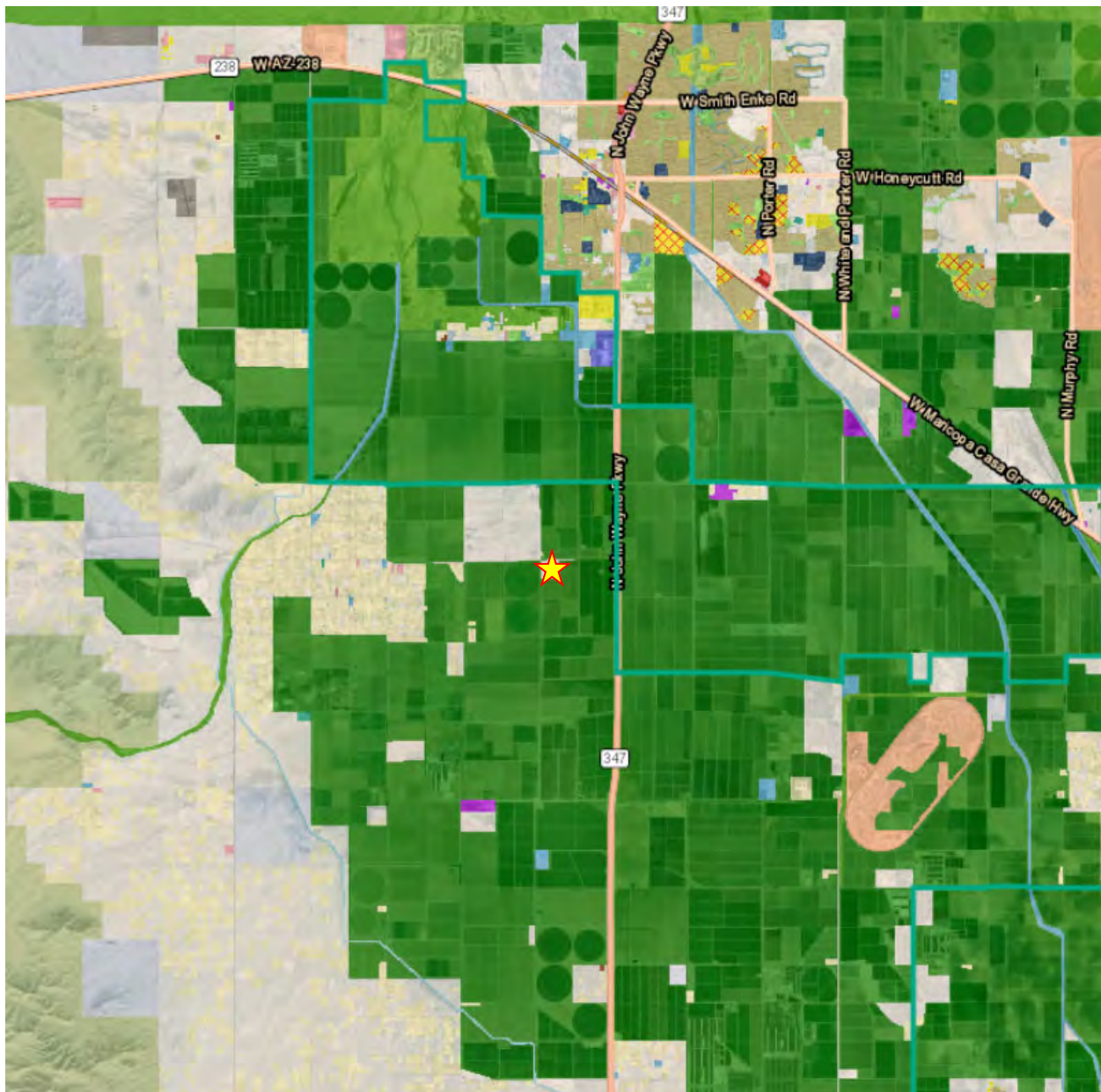

Future land use surrounding the subject site is expected to be a mix of residential, commercial, employment, and mixed uses. Low density residential development is expected to be the dominant land use and will stretch to areas south, east, and west of the subject site, as well as continued development to the north, northwest, and northeast. Continued residential development will eventually support new retail development, which is expected to cluster along major roadways, such as SR 238, Maricopa-Casa Grande Highway, White and Parker Road, and John Wayne Parkway to the north of the subject site as well as SR 347 south of the subject site.

Existing Land Use Map

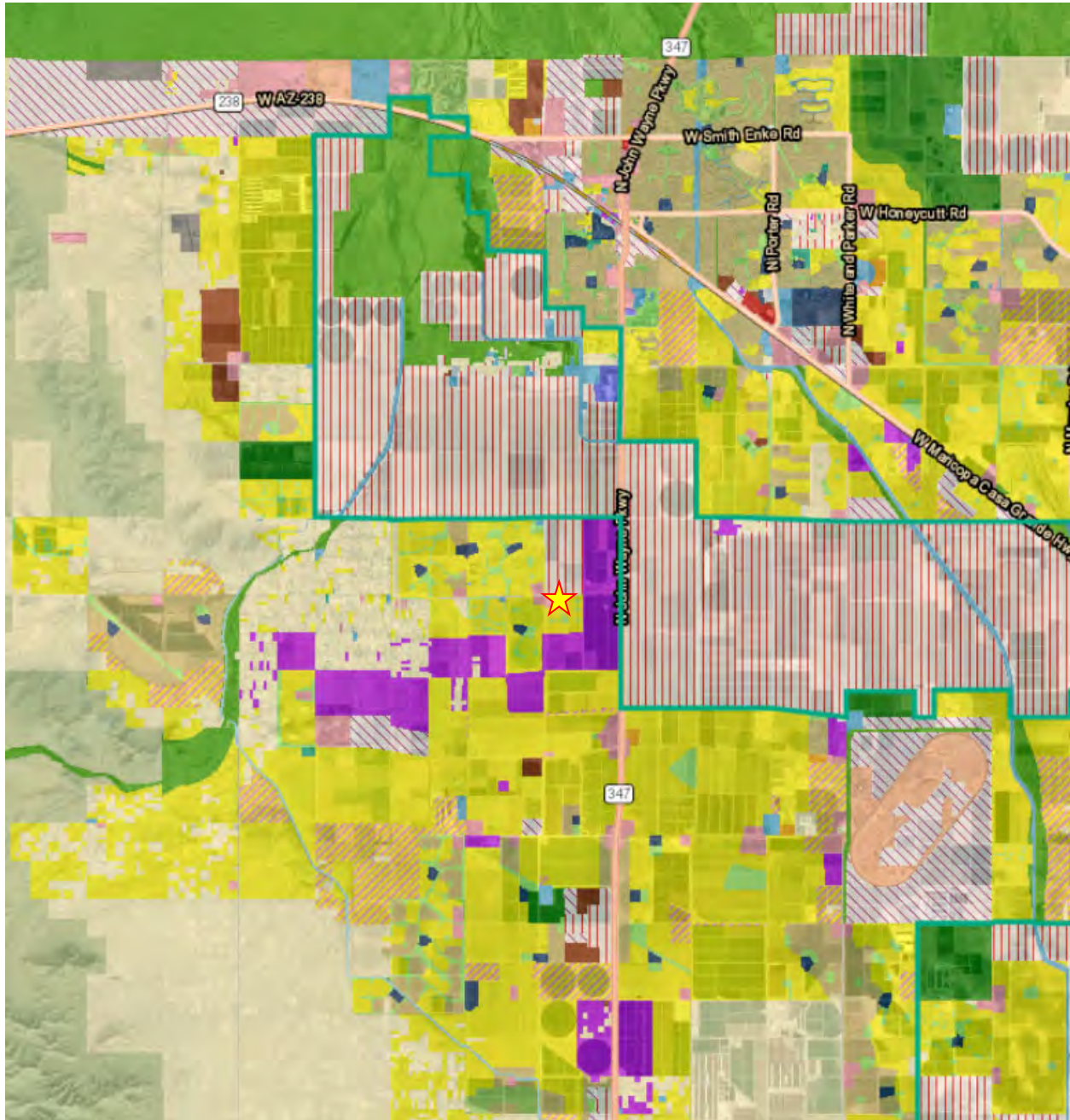

The City of Maricopa’s General Plan envisions several village centers. Village Centers are to be higher intensity areas with high concentrations of commercial and/or employment. In general, village centers are located along the region’s highways and other main thoroughfares. In the southern area, the closest village center is planned for SR 347 and Teel Road. Additional commercial areas and parcels are also identified, the majority of which is along or north of the Maricopa-Casa Grande Highway.

City of Maricopa General Plan – Future Land Use Map

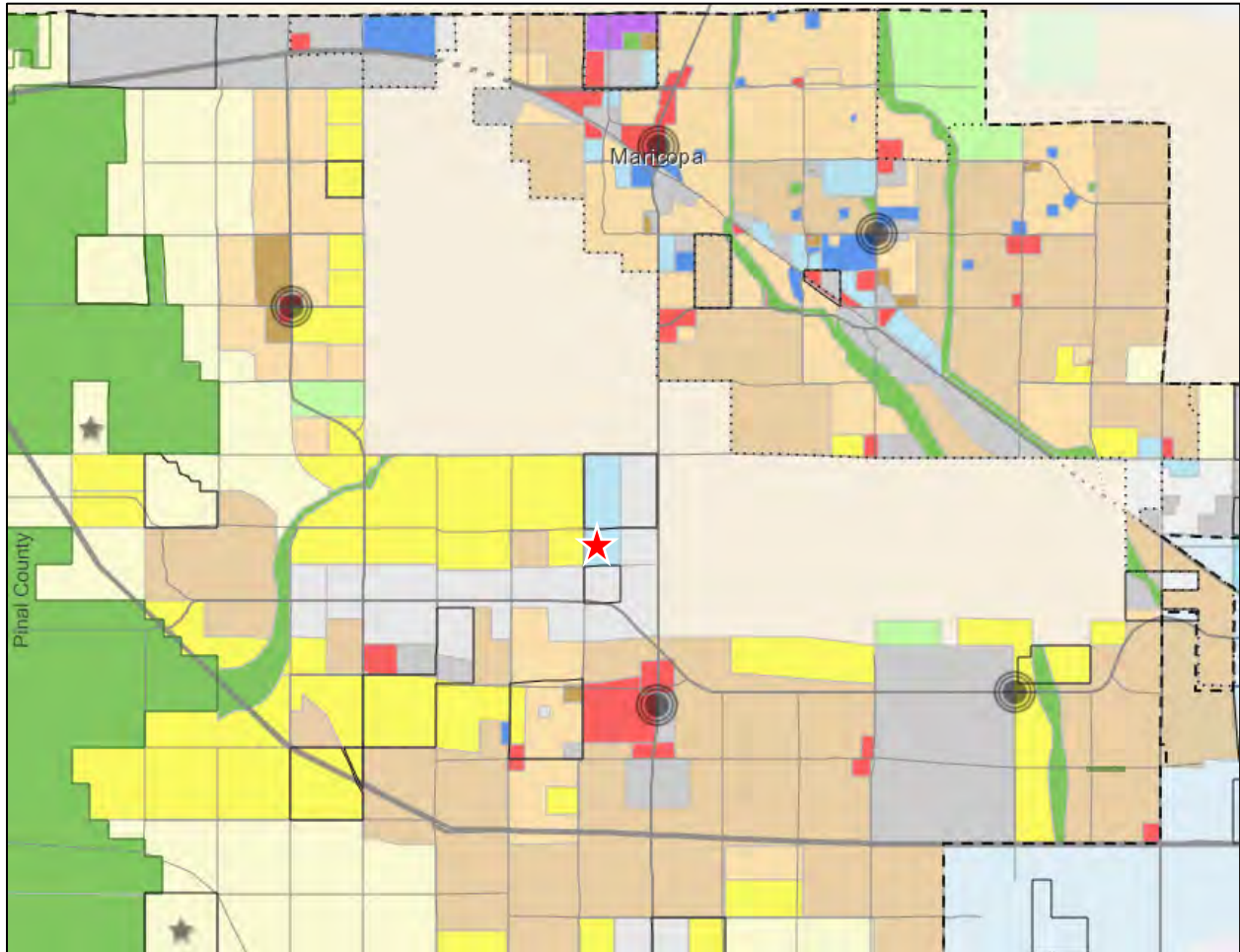

Similarly, the Pinal County Comprehensive Plan denotes high intensity and medium intensity activity centers throughout the County which would be targeted for commercial and employment uses. The Comprehensive Plan also chooses high traffic highways and arterials for these activity centers around the City of Maricopa, including SR 347, SR 84, and the Maricopa-Casa Grande Highway. The subject site is located in an area designated for moderate low density residential.



Pinal County Comprehensive Plan

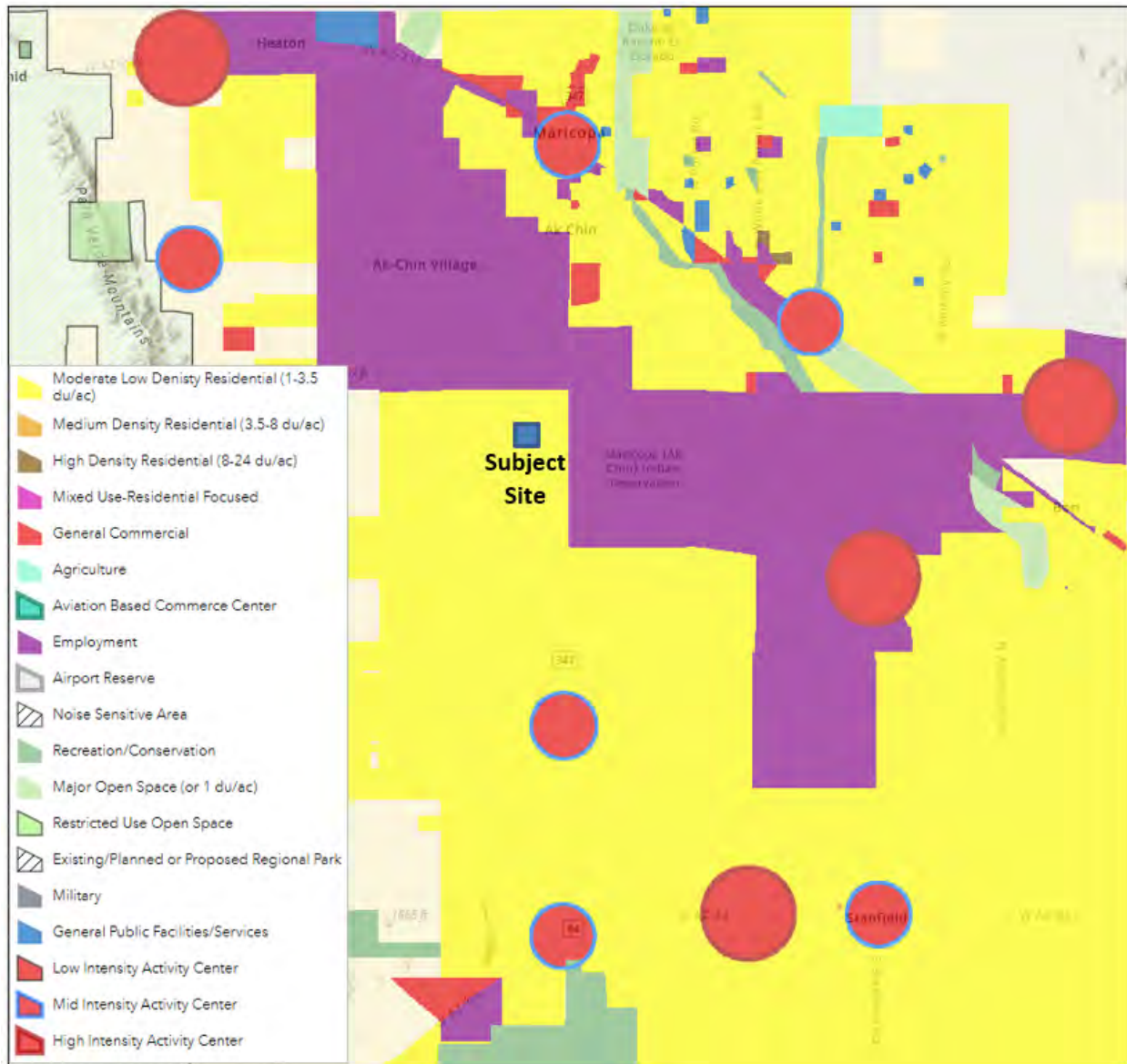

The Ak Chin Indian Community also sits to the area north of the subject site and south of the City of Maricopa. As the General Plan map and zoning map illustrate, Ak Chin Indian Community has designated a one-mile stretch of SR-347 frontage starting south of Farrell Road as Commercial. Frontage on the north half mile contains Harrah’s Ak Chin Casino and Hotel and the Ak Chin Circle Entertainment Center which includes movie theaters, bowling, arcade gaming, event facilities, outdoor amphitheater, and dining.

Ak Chin Indian Community also extends an additional one mile south down to Peters and Nall Road. Currently, the land use plan designates the east and west side of SR 347 as agriculture.



However, the Community has shown that they are interested in continuing commercial development and could reclassify these areas for commercial uses as well.

Ak Chin Indian Community Land Use Map

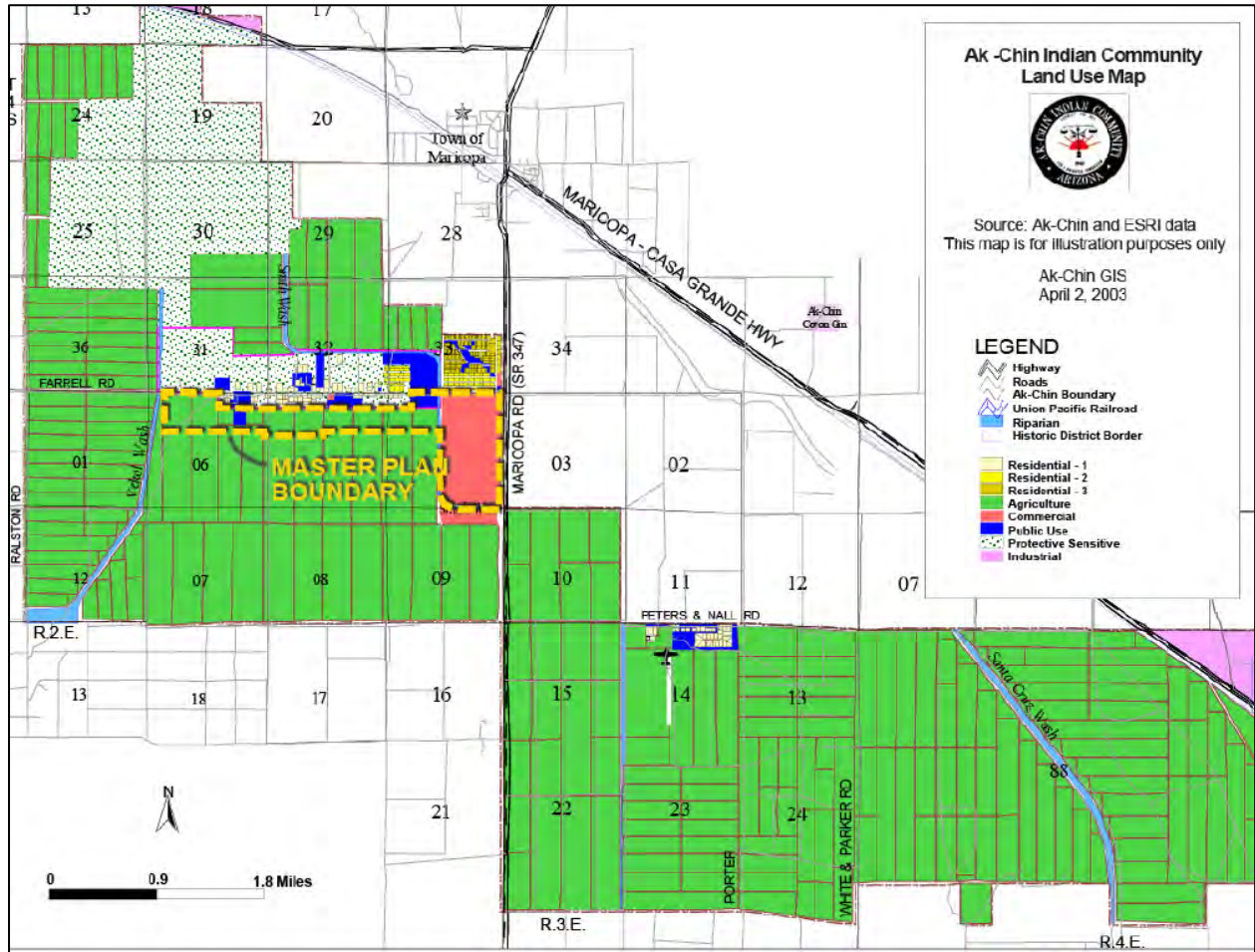

Ak Chin Indian Community Zoning Map

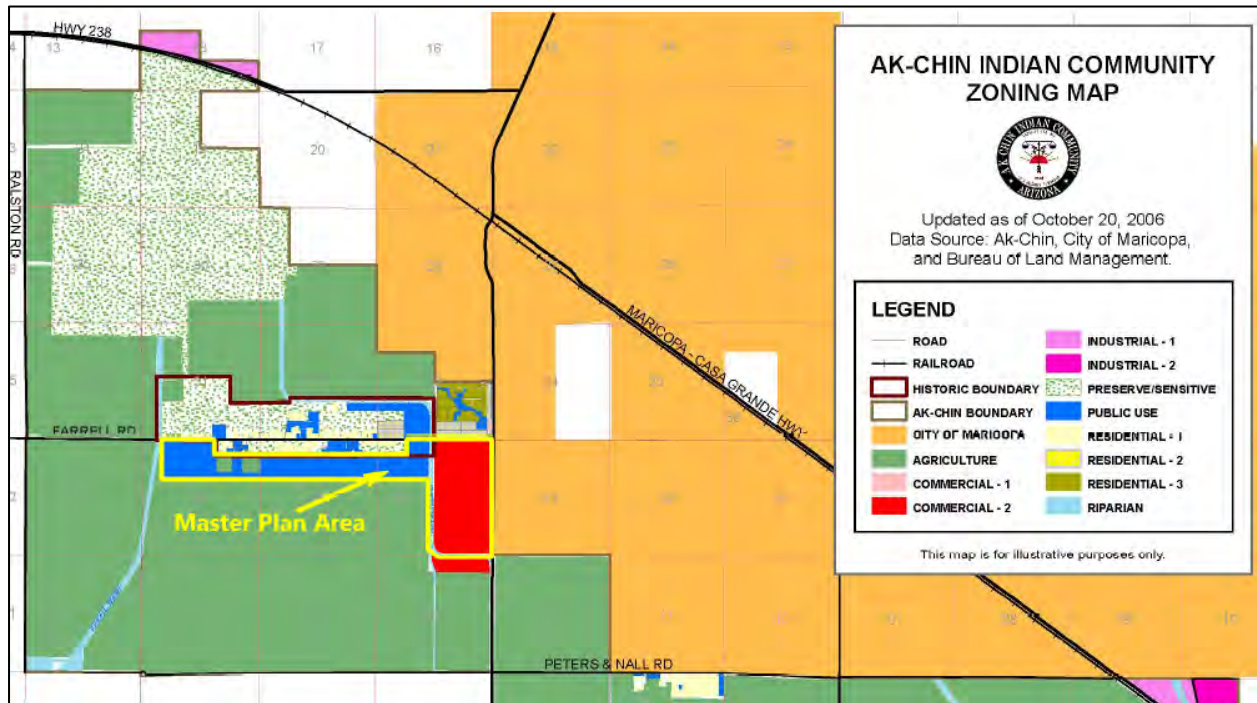

3.4 Summary

The population of the 7-mile Primary Market Area today is estimated at 53,000 persons. The Primary Market Area is expected to increase by at least 5,900 new households between 2020 and 2030. Household incomes also exceed the County median by 23%. Residents have above average levels of education which is also consistent with resident incomes. Overall, we conclude that the Primary Market Area should continue to experience moderate growth trends, concentrated in the northern portions of the PMA.

The southern area and 3-mile radius surrounding the subject site has a much smaller population base and both current and projected population are not conducive to any significant retail developer interest.

While the northern area is still expected to capture the large majority of future growth for the foreseeable future, the southern area is also expected to develop, with numerous plans that were initially conceived during the 2005-2007 housing boom and are now being reconsidered. While still a decade or more away, the southern area is expected to spur some retail development. Expectations are for SR 347 to be the preferred location for a future retail development.



4.0 Retail Supply & Demand Analysis

4.1 Market Area Retail Demand

The current population of the 7-mile Primary Market Area is estimated at 52,992 persons. This population level is considered sufficient to provide support for a moderate level of commercial and retail development.

The Primary Market Area will need to continue to increase in population before additional retail development will occur. Some retailers, such as Walmart, are highly aggressive in establishing their market territory based on growth prospects, even though the current population may not provide optimum demand levels. The existing Walmart location at Maricopa-Casa Grande Highway and Porter Road provides that presence and there isn't any likelihood that an additional location in the region is warranted.

Grocery stores are an important anchor for local-serving retail shopping centers, drawing shoppers to the center and creating foot traffic for smaller retailers who occupy the inline shops. From a demand perspective, across the Greater Phoenix area, there are approximately 22,200 persons for every traditional grocery chain (Fry's, Safeway, Bashas' and Albertson's). When natural food stores (Whole Foods and Sprouts) and specialty stores such as AJ's and Trader Joe's are added to the total, the demand level declines to 18,400 persons per store. The ratio of persons per grocery store has been growing over the last 20 years due to increased competition from major chains such as Walmart, Target, and Costco, to name a few. This has resulted in consolidation in the grocery industry, the latest of which is the purchase of the Safeway chain by Albertson's.

At a population of just under 53,000 persons, the 7-mile Primary Market Area today can support between two and three grocery stores. Based on MAG forecasts, by 2030, one additional store could be supported. Additional population growth from 2030 through 2050 is enough to attract another grocery store.

When comparing these metrics to the Primary Market Area, there are already three grocery store options (Fry's, Bashas', and a Walmart Supercenter). There is also a Sprout's currently under construction which would be a fourth grocery store. Thus, the existing and future supply of grocery stores appears to satisfy much of the future demand for decades. One additional store location may be warranted over the next 10-20 years in the PMA.

The reasons for low level of retail development in 7-mile PMA include the following.



- At a current population of just under 53,000 persons, the region cannot support additional retailers who require a large population base. For instance, Walmart has 52 supercenters in Greater Phoenix for an average of 91,000 persons per store (and already present in the market area). Home Depot has 35 stores in Maricopa County and one store in Pinal County in Casa Grande which equates to one store for every 135,300 persons for the entire metro area. Other large format retailers such as Target and Lowe’s have similar persons per store ratios. Overall, the Primary Market Area is not large enough today to support additional significant large format, anchor retailers.
- Prior to the Great Recession, retailers were very aggressive in forward planning for store locations based on expectations of population growth. Greater Phoenix, with its tremendous history of rapid growth, is one region that historically has seen retailers anticipate where demand will develop and then enter the market in advance of that demand. The impact of the Great Recession, however, has resulted in the delay or cancellation of planned retail centers. Many of these planned centers have still not come to fruition. Retailers are also much more cautious today given the impact of online sales and slower population growth across the country.
- E-Commerce has had a significant impact on the development of brick-and-mortar retail centers. In 2021, E-Commerce accounted for 14.4% of all retail sales in the U.S., up from just 1.1% in 2001. Since 2010, E-Commerce has been growing at an average rate of 12.6% per year. The country has witnessed the loss of traditional shopping center retailers such as bookstores, shoe stores, sporting goods stores, toy stores, and florists. The consolidation of businesses has also occurred in many segments of the market (groceries, office supplies, electronics). As a result, retailers have become much more cautious in planning for new outlets unless there are significant signs of demand and/or population growth.

Based on the ratios of persons per retail store, we can conclude that the demand for retail services in the Primary Market Area is likely satisfied by the current level of retail development in the community, including developments currently under construction.

A second method of determining demand for commercial development is to evaluate the spending potential of the Primary Market Area population based on the U.S. Consumer Expenditure Survey (CES). The Survey is a long-term nationwide household survey conducted by the U.S. Bureau of Labor Statistics (BLS) to find out how Americans spend their money. It is the only federal government survey that provides information on the complete range of consumers’ expenditures as well as their incomes and demographic characteristics. The CES is used by



analysts to determine the demand for retail goods and services based on household income levels.

As noted previously, the 2021 median income of Primary Market Area residents ranges from \$46,371 to \$74,799 based on U.S. Census data. An economic model was prepared for this study to estimate the amount of retail and restaurant spending that may be derived from residents living in the Primary Market Area.

The following table outlines the spending that may be generated from the various rings within the Primary Market Area surrounding the subject site. Area residents would be expected to spend approximately 27%-36% of gross income or \$16,655 to \$20,316 per household on retail goods and services and restaurants, excluding spending on the purchase of a vehicle. Retail spending is then divided into two groups: local-serving retail spending and regional-serving retail spending. Local-serving spending includes groceries and other convenience goods and services (medical prescriptions, household supplies, tobacco products, and personal care products and services). Regional-serving spending is related to big-ticket items that typically are sold in large-format retail centers such as furniture, electronics, appliances, flooring, and apparel.

The following table shows that the typical Primary Market Area household is expected to spend an estimated \$7,651 to \$8,915 on local-serving retail items and \$6,298 to \$8,034 on regional-serving items. The remaining \$2,706 to \$3,367 is spent in restaurants and bars. Local-serving retail spending is then divided into grocery spending and non-grocery spending (household goods, day care, medical prescriptions and supplies, personal care products, etc.)

The lower part of the table converts the local-serving spending to potential retail square footage. For instance, grocery spending in the 7-mile Primary Market Area is estimated at \$77.9 million for the 17,804 households. At an average retail sales rate of \$500 per square foot for a supermarket, the Primary Market Area can support 155,900 square feet of grocery store space. However, within the 3-mile PMA, the existing 468 households can support just 3,635 square feet of grocery store space, well below the threshold for development.

Likewise, non-grocery, local retail spending of \$4,537 per household in the 7-mile radius generates demand for 269,250 square feet of additional retail space at \$300 per square foot retail sales. In the 3-mile radius, that figure is only 2,532 square feet.

Regional retail of 286,089 square feet can also be supported by the local population in the 7-mile radius. That figure drops to 5,895 square feet in the 3-mile radius.



Restaurant spending supports another 119,896 square feet of space in the 7-mile radius. In the 3-mile radius, that figure is only 2,532 square feet.

Together, an estimated 831,127 square feet of retail space can be supported in the 7-mile Primary Market Area based on the current population.

Retail Spending Analysis						
Papago Rd & Green Rd Rd Primary Market Area						
	3-mile		5-mile		7-mile	
Income & Spending Assumptions	Dollars	% of Income	Dollars	% of Income	Dollars	% of Income
Market Area Median Household Income 2021	\$46,371		\$65,590		\$74,799	
Total Retail Spending/HH (Excluding vehicles)	\$16,655	35.9%	\$19,130	29.2%	\$20,316	27.2%
Local-Serving Retail Spending	\$7,651	16.5%	\$8,506	13.0%	\$8,915	11.9%
Grocery Spending/HH	\$3,883	8.4%	\$4,218	6.4%	\$4,378	5.9%
Non-Grocery Local-Serving Retail Spending/HH	\$3,768	8.1%	\$4,288	6.5%	\$4,537	6.1%
Regional-Serving Retail Spending/HH	\$6,298	13.6%	\$7,472	11.4%	\$8,034	10.7%
Restaurant Spending/HH	\$2,706	5.8%	\$3,153	4.8%	\$3,367	4.5%
<hr/>						
2021 Population	1,431		17,079		52,992	
Households	468		5,534		17,804	
<hr/>						
	Retail		Retail		Retail	
Supportable Local-Serving Retail Demand	Demand		Demand		Demand	
Total Grocery Spending	\$1,817,423		\$23,341,238		\$77,946,308	
Supportable SF at \$500 Per SF in Sales	3,635		46,682		155,893	
Non-Grocery Local-Serving Retail Spending	\$1,763,464		\$23,728,951		\$80,774,940	
Supportable SF at \$300 Per SF in Sales	5,878		79,097		269,250	
Restaurant Spending	\$1,266,192		\$17,447,548		\$59,947,807	
Supportable SF at \$500 Per SF in Sales	2,532		34,895		119,896	
Regional Serving Retail Spending	\$2,947,462		\$41,349,522		\$143,044,397	
Supportable SF at \$500 Per SF in Sales	5,895		82,699		286,089	
TOTAL LOCAL-SERVING RETAIL DEMAND	17,940		243,373		831,127	
<hr/>						
Sources: U.S. Consumer Expenditure Survey; AZ DOA; Elliott D. Pollack & Company						

Today, the total estimated retail space within the PMA is approximately 1.1 million square feet which exceeds the local demand within the 7-mile Primary Market Area. There are an additional 2,100 households in the City of Maricopa not within the 7-mile radius that also support retail space in the PMA. There is also a small amount of vacant retail space in the PMA, estimated at



approximately 41,844 square feet. Given the mix of local serving retail, restaurants, and regional serving retail currently present in the market area, it appears that the area is at equilibrium .

There is also retail development occurring in the PMA totaling nearly 141,795 square feet . Development under construction includes a Sprout’s, Marshalls, Petco, and approximately 70,000 square feet of available shops and pads for restaurants, shops, and space for consumer services such as banking, medical, dental, and insurance.

Future retail development will be heavily dependent on new residential growth in the area to spur new construction.

4.2 Retail Forecast

The most recent population forecast for the 7-mile Primary Market Area is for growth of 5,907 new households over the next ten years. In addition, the longer-term forecast anticipates 3,472 new households between 2030 and 2040 as well as 4,980 new households from 2040 to 2055. Total household growth over the next 35 years in the Primary Market Area is approximately 14,360 households.

Based on the above analysis, a 35-year forecast for retail demand was prepared for the Primary Market Area for the timeframe from 2020 to 2055. The forecast concludes that the demand for local and regional serving retail within the Primary Market Area will total approximately 96.2 acres, or 670,326 square feet of building space through 2055.

Retail Demand Forecast				
Papago Rd & Green Rd 7-mile Radius				
	2030	2040	2055	35-Year Total
Household Growth	5,907	3,472	4,980	14,359
New Retail Demand (SF)	275,769	162,103	232,455	670,326
New Retail Demand (acres)	39.6	23.3	33.4	96.2
Sources: MAG, 2019; U.S. Consumer Expenditure Survey; AZ DOR; Pinal County Assessor; City of Maricopa; Elliott D. Pollack & Company				



4.3 Supply

The supply of future available retail space can be found within existing retail or mixed-use developments as well as parcels of land currently planned for commercial uses. The following is a summary of available inventory located within the Primary Market Area.

There were seven existing retail developments identified in the Primary Market Area that have either vacant space, available pads, or both. Vacancy within these developments is as small as one shop totaling 1,200 square feet up to a significant amount of vacancy as a percent of the total center such as at John Wayne Parkway and Edison Avenue or along the Maricopa-Casa Grande Highway. Total vacant/available space among these developments is 41,844 square feet.

Commercial Real Estate Assets SEC Papago Rd & Green Rd PMA	
Existing Projects	Available SF
19756 N John Wayne Pky	2,900
20800 N John Wayne Pky	1,200
44500 W Edison Rd	2,981
21542 N John Wayne Pky	5,478
19590 N Maricopa Rd	2,760
41840 W Maricopa Casa Grande Hwy	14,490
44460 W Edison Rd	12,035
Total Available SF	41,844
Source: Elliott D. Pollack & Company; Town of Queen Creek; Maricopa Association of Governments; Maricopa County Assessor; Velocity Retail Group; Phoenix Commercial Advisors; Western Retail Advisors; Phoenix West Commercial; SRS Real Estate Partners; ZELL Commercial Real Estate Services; Cushman & Wakefield	

Through the course of this research, an estimated 392,775 square feet of retail space has been identified in the development pipeline within nine projects. Three projects, totaling 141,795 square feet are currently under construction at the corners of John Wayne Parkway and Edison Avenue as well as 18893 W Honeycutt Road. These projects include a Sprout's anchored neighborhood center and a Petco anchored development. The remaining developments have uncertain development timelines. If all are built, these projects will fill the region's retail needs for several years.



Retail Development Pipeline Papago Rd & Green Rd Primary Market Area				
Property Address	Property Name	Property Type	SF	Status
John Wayne Pky & Edison Ave	Sonoran Creek Marketplace	Community Center	102,072	Under Construction
18893 W Honeycutt Rd		Retail	19,723	Under Construction
44460 W Edison Rd		Retail	20,000	Under Renovation
41650 W Maricopa Casa Grande Hwy	The Wells	Retail	100,000	Proposed
SEC Hwy 347 & Edison St		Retail	2,500	Proposed
44500 W Edison Rd	Maricopa Marketplace II	Neighborhood Center	33,000	Proposed
NEC John Wayne Pky & Honeycutt Rd		Retail	10,480	Proposed
SEC Hwy 347 & Edison St		Retail	5,000	Proposed
NEC Edison Rd & John Wayne		Retail	100,000	Proposed
TOTAL			392,775	
Source: Elliott D. Pollack & Company; Thompson Thrift; CBRE; NAI Horizon; Commercial Properties, Inc.; Phoenix Commercial Advisors; Kidder Matthews; SRS Real Estate Partners; Newmark; Cushman & Wakefield				

Available Vacant Retail Land

In addition to existing centers with available space, 35 vacant retail parcels were located within the Primary Market Area, including the subject site. Combined, these vacant parcels total 912 acres. Utilizing a typical range of Floor Area Ratio (FAR) from .09 to .18, these parcels could accommodate over 6.7 million square feet of future retail or commercial development (under construction and proposed projects are included in this amount). Potential commercial development within the Ak Chin Indian Community is also not included in the total.

In total, there is nearly 6.8 million square feet of vacant space or land available for future retail development within the Primary Market Area.



Commercial Real Estate Assets SEC Papago Rd & Green Rd PMA	
Commercial Land Parcels	Acres
SEC Papago & Green	15
SWC Papago & Green	15
NEC Papago & Green	31.8
NWC Papago & Green	15
Porter Rd & Maricopa Hwy (The Wells)	35.2
NWC Farrell & White and Parker Rd	40.0
NEC Farrell Rd & Maricopa Hwy	31.0
SEC Farrell & White and Parker Rd	52
Bowlin & White & Parker Rd	27.0
SWC Edison Rd & John Wayne Pkwy	19
W of SWC Edison Rd & John Wayne Pkwy	15.8
Edison Pointe	1.5
SEC Hathaway & John Wayne Pkwy	5.4
SWC Porter & Smith Enke	3.0
NWC Porter & Smith Enke	3.5
Golden Hills Dr & Smith Rd	10.4
SWC Barnes Rd & White and Parker Rd	16.9
SEC Barnes Rd & White and Parker Rd	17.8
NWC Louis Johnson Dr & White and Parker Rd	41.6
SWC Louis Johnson Dr & White and Parker Rd	26.0
SWC Louis Johnson Dr & Smith Rd	11.1
Louis Johnson Dr & John Wayne Pkwy	47.7
SWC Louis Johnson Dr & Green Rd	13.5
SWC Louis Johnson Dr & Amarillo Valley Rd	14.2
SWC Barnes Rd & Amarillo Valley Rd	35.5
Teel Rd & John Wayne Pkwy	87.8
SWC Val Vista Rd & Ralston Rd	17.0
Hidden Valley Rd & Papago Rd	15.2
NWC Papago Rd & Amarillo Valley Rd	16.1
NWC Peters and Nail Rd & White and Parker Rd	15.2
NEC Peters and Nail Rd & Maricopa Hwy	24.4
Maricopa Hwy & Hartman Rd	38.0
NEC SR 238 & Green Rd	85.8
SEC SR 238 & Green Rd	36.6
NWC Bowlin Rd & John Wayne Pkwy	31.2
Total Acres	912.2
Gross SF	39,735,432
Yield SF (0.09-0.18 FAR)	6,738,100
Total Potential SF	6,779,944
Source: Elliott D. Pollack & Company; Town of Queen Creek; Maricopa Association of Governments; Maricopa County Assessor; Velocity Retail Group; Phoenix Commercial Advisors; Western Retail Advisors; Phoenix West Commercial; SRS Real Estate Partners; ZELL Commercial Real Estate Services; Cushman & Wakefield	



4.4 Site Comparison

The map below displays the supply of available commercial land in proximity to the subject site. As the map illustrates, there are numerous commercial sites located along John Wayne Parkway and Maricopa-Casa Grande Highway, as well as along SR 238 and White and Parker Road. Every one of these sites are competing with the subject site property to attract commercial development. Additionally, compared to expected demand, commercial land in the area is considered excessively oversupplied. Many of the sites will not be needed for commercial development.

Retail Supply Map – Primary Market Area

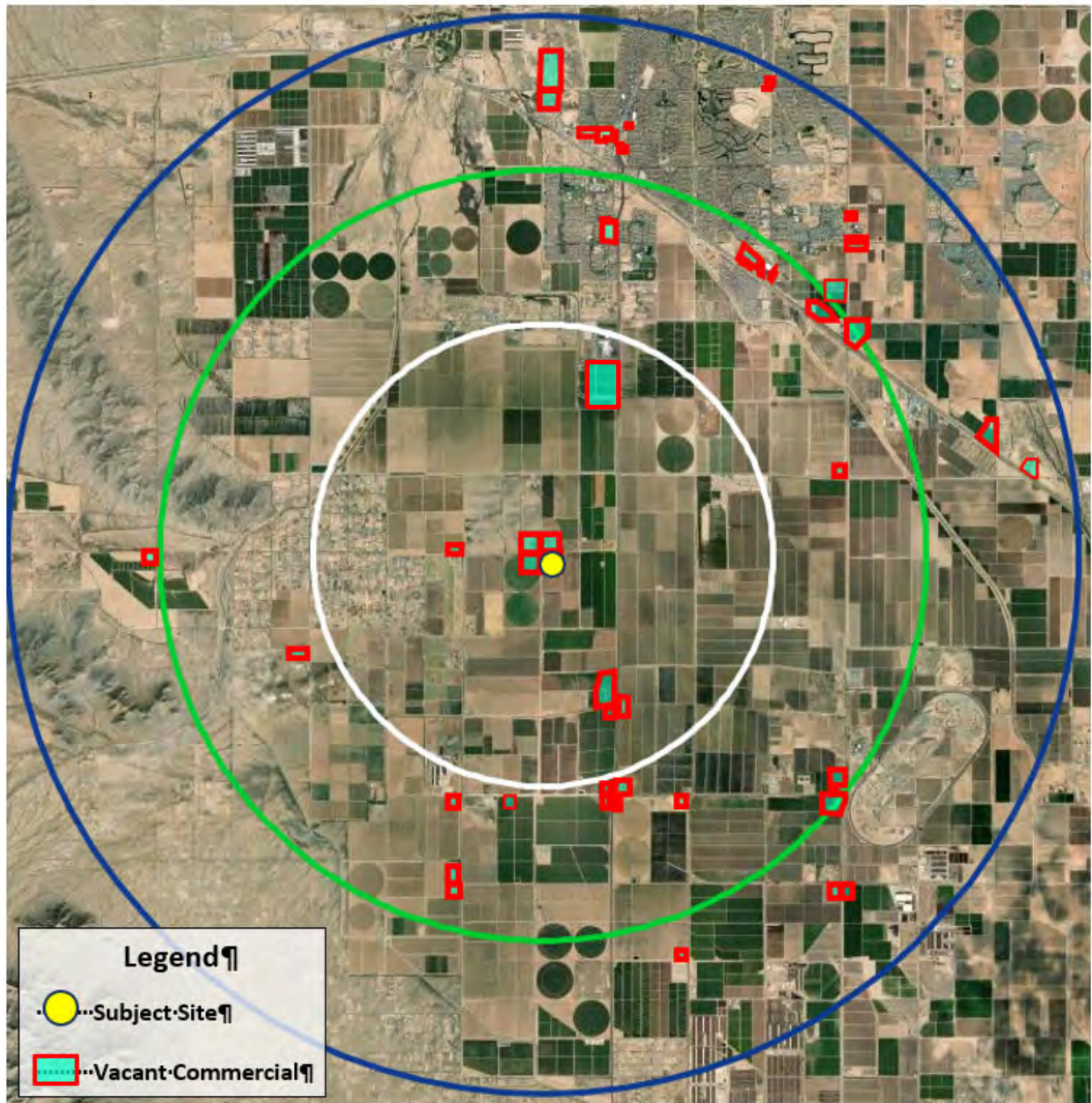

The subject site is at a disadvantage competitively with many of the alternative sites. First and foremost, retailers will prefer most of the sites located to the north closer to the city center, either in the area of Maricopa-Casa Grande Highway and Porter Road or along the SR 347 in the northern portion of the city. Residential developments in the southern area around the subject site would be considered part of their trade area and will make the drive to retail centers in the north. There is currently far too much risk to locate outside of the concentration of populated city boundaries. Also, with frontage along major roadways such as SR 238, SR 347, Porter Road, White and Parker Road, and Maricopa-Casa Grande Highway, these competing sites enjoy better visibility, and substantially higher traffic volumes.

In contrast, the subject site is located one mile west of SR 347 Highway (John Wayne Parkway), providing no highway frontage or visibility with the only frontage along Papago Road and Green Road.

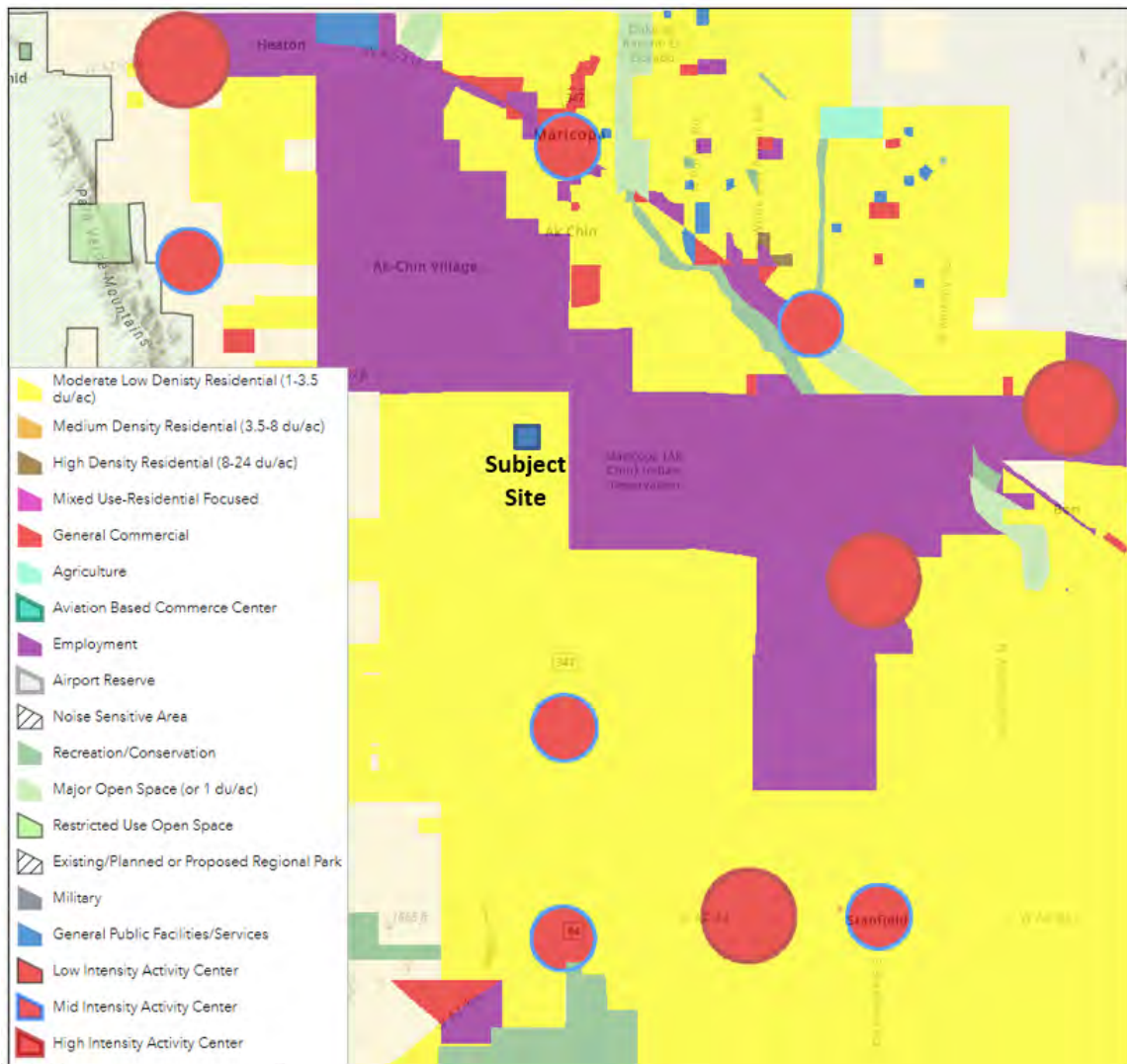

The subject site also has three competing sites in close proximity, all with significant frontage along Papago and Green Road and range in size from 15 to 32 acres. All four corners at the intersection of Papago Road and Green Road are designated for commercial or mixed use development. Clearly, there are too many sites for commercial development. This is especially true considering the extremely modest population base and relatively low level of future residential development expected in this southern area. Even when the subject site’s proposed developments and neighboring subdivisions build out, it will not be sufficient to trigger enough retail demand that the acreages offered on these parcels can accommodate.

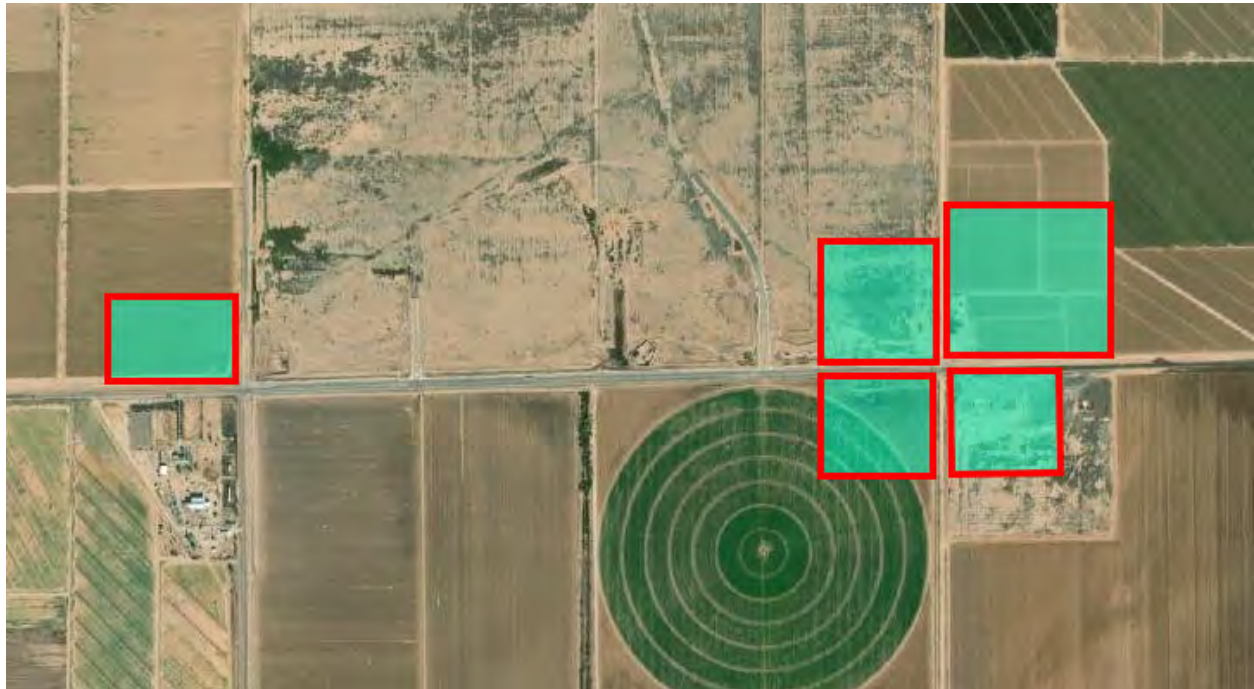

4.5 Summary

The forecasted retail demand of 670,326 square feet (gross land demand of 96.2 acres) is substantially lower than the estimated 6.8 million square feet of availability (combining 41,844 square feet of available space and land within existing centers and 912 acres of vacant commercial land) within the Primary Market Area. Compared to the available vacant space and available commercial land, there is far too much land in the Primary Market Area designated for future retail development. Potential commercial development within the Ak Chin Indian Community is also not included in the total.



Retail Supply/Demand Forecast				
Papago Rd & Green Rd 7-mile Radius				
	2030	2040	2055	35-Year Total
Household Growth	5,907	3,472	4,980	14,359
New Retail Demand (SF)	275,769	162,103	232,455	670,326
New Retail Demand (acres)	39.6	23.3	33.4	96.2
Supply (Available for Additional Retail Development)				
			<u>Acres</u>	<u>SF</u>
Existing Retail Centers				41,844
Vacant Land			912	6,738,100
TOTAL				6,779,944
Sources: MAG, 2019; U.S. Consumer Expenditure Survey; AZ DOR; Pinal County Assessor; City of Maricopa; Elliott D. Pollack & Company				

Even with more aggressive growth forecast scenarios, it is apparent that there is an oversupply of commercial land that is out of balance with future need. The area will never come close to needing the current amount of available commercial land.

Similar comments were recently echoed by the City of Maricopa. Based on their General Plan and the build out potential of the City's population, City staff estimated that there is over twice the amount of available commercial land that will be needed even after the City's population nearly triples in size.²

² <https://www.inmaricopa.com/catalyst-residential-growth-spurs-commercial-activity/>



5.0 Conclusions & Recommendations

- The retail marketplace has been significantly impacted by recent recessions (both the Great Recession and COVID-19), e-commerce and the rise of supercenters and warehouse clubs.
 - For the Greater Phoenix area, the Great Recession resulted in much slower population and employment growth and retailers have become much more cautious planning for new stores. Some ten years after the end of the recession, retail development has not returned to prior construction levels. This trend may continue for the foreseeable future, especially with the recent impacts of the COVID-19 pandemic and will impact properties currently designated for commercial development.
 - Virtually all retail sectors experienced substantial losses due to the COVID-19 pandemic, especially clothing, furniture, motor vehicles, sporting goods, department stores, and restaurants and bars. Non-essential purchases shifted substantially to e-commerce.
 - It remains to be seen whether or not the pandemic will permanently shift consumer behavior more heavily toward e-commerce. This could have material impacts on future commercial development and investment. Regardless, the shift toward online shopping will continue.
- The latest forecast for population growth in the Primary Market Area concludes that the demand for additional local serving retail land will total approximately 670,300 square feet or the equivalent of 96.2 acres over the next 35 years (through 2055). However, there is nearly 6.8 million square feet acres of available retail space and land (912 acres) within the Primary Market Area. Potential commercial development within the Ak Chin Indian Community is also not included in the total. There is far too much land in the Primary Market Area designated for future retail development compared to forecasted demand.
- There are at least 35 available commercial sites located within the subject site's primary market area. Every one of these sites are competing with the subject site property to attract retail development. The subject site is at a disadvantage competitively with many of the alternative sites. First and foremost, retailers will prefer most of the sites located to the north closer to the city center, either in the area of Maricopa-Casa Grande Highway and Porter Road or along the SR 347 in the northern portion of the city. Residential developments in the southern area around the subject site would be considered part of their trade area and will make the drive to retail centers in the north. There is currently far too much risk to locate outside of the concentration of populated city boundaries. Also, with frontage along major roadways such as SR 238, SR 347, Porter Road, White and Parker Road, and Maricopa-



Casa Grande Highway, these competing sites enjoy better visibility, and substantially higher traffic volumes. In contrast, the subject site is located one mile west of SR 347 Highway (John Wayne Parkway), providing no highway frontage or visibility with the only frontage along Papago Road and Green Road. The disadvantages compared to competing sites, combined with the fact that there is an excess of commercial land in the area, bodes poorly for the subject site's prospects to generate retail development interest.

- There are already sufficient neighborhood retail centers anchored by grocery stores for the market area's current and future population. A new Sprout's is currently under construction and the PMA will also see a new anchor pet supply store and surrounding shops and pads. A new grocery store may be justified with sufficient new population growth, but the subject site would not be a preferred site.
- The proposed residential developments, both at the subject site and on neighboring properties, will help to support existing retail assets within the Maricopa region. Each new additional resident will create demand for additional local serving retail and restaurants. Continued residential development in all forms within the market area will be critical to the eventual success of existing retail assets and additional commercial development. Local residents will be the main source of retail demand and also provide a local workforce for office development. This residential development must come first, eventually building to a critical mass of residents to attract additional retailers.
- In our opinion, the rezoning of the subject site to residential uses will not affect the area's efforts to continue to attract new commercial development to the community. The region has a significant inventory of commercial land that will provide for the long-term economic health of the community. Additionally, as a residential project, new residents will support existing and planned commercial development.



September 27, 2021
Revised: April 15, 2022



VENIDA

Planned Area Development
Pinal County, Arizona

OPEN SPACE AND RECREATION PLAN

Case #: PZ-PD-042-21



4550 N 12th Street
Phoenix, AZ 85014

CVL Job. No: 1-01-03723-01

OPEN SPACE AND RECREATION PLAN

For
Venida

Pinal County, Arizona

Case #: PZ-PD-042-21

Developer

LGI Homes - Arizona, LLC
9105 East Del Camino Drive, Suite 118
Scottsdale, Arizona 85258
Attn: Rick Tayrien

**Planning/Civil Engineering
Consultant**

Coe & Van Loo Consultants, Inc.
4550 North 12th Street
Phoenix, Arizona 85014
Attn: Julie Vermillion
602-285-4765

Contents

A. Executive Summary: Open Space and Recreation Plan	1
1. Site Analysis	1
2. Site Plan	2
3. Compliance with County Standards	3
4. Integration with the County’s Open Space	3
B. Existing Conditions, Context, and Site Analysis	3
1. Project Context: Site Description	3
2. Project Context: Regional Location	3
3. Surrounding Recreation Opportunities	4
4. Project Context: Existing Connectivity and Area Trails	4
5. Target Market	5
6. Site and View Shed Analysis	5
7. Slope Analysis	5
8. Preliminary Hydrology Analysis	6
9. Flood Zone Designation	6
10. Archaeological Sites Investigation	6
11. Existing Vegetation and Biological Habitat Analysis	7
C. Implementation: Proposed Development Plan	7
1. Development Concept	7
2. Conservation Open Space	9
3. Developed Open Space	9
4. Recreation Area Open Space	10
5. Landscaping	10
D. Compliance with County Guidelines and General OSRP Design Guidelines	11
1. Conformance to the Open Space and Recreation Area Manual (OSRAM)	11
2. Conformance to the PCDSC	15

Exhibits

Aerial Map	Exhibit A
Vicinity	Exhibit B
Context Map	Exhibit C
Exiting Conditions: Alta Survey (Excerpt)	Exhibit D
Site and Slope Analysis Plan	Exhibit E
Preliminary Hydrology Analysis - Proposed Drainage Map	Exhibit F
Native Plant Inventory	Exhibit G
Native Plant Inventory List	Exhibit H
Proposed Site Plan	Exhibit I
Open Space and Amenities Plan	Exhibit J
Wall and Signage Plan	Exhibit K
Major Entry Plan	Exhibit L
Main Park Conceptual Landscape Plan	Exhibit M
Primary Entry Elevation	Exhibit N
Secondary Entry and Wall Elevations	Exhibit O
Landscape Master Plan	Exhibit P
Landscape Tract Plan	Exhibit Q
Archaeological Records Search Results	Exhibit R
Phasing Plan	Exhibit S
Open Space Lighting Plan	Exhibit T
Lake Location Plan	Exhibit U

A. Executive Summary: Open Space and Recreation Plan

Venida is a previously approved master planned community located at the southeast corner of Papago Road and Green Road in Pinal County, Arizona (Exhibit A: Vicinity Map). Venida encompasses approximately 158.25 acres of undeveloped agricultural land intended for development of a master planned community zoned as R-7 Planned Area Development (PAD). A major PAD amendment is currently in process.

1. Site Analysis

Analysis of the site and surrounding area revealed the following (See Exhibit B: Location Map for a visual overview of the site's current condition as disturbed, previously agricultural land):

- *Nearby neighborhood parks were identified that will support outdoor recreation for the proposed development, including Palo Verde Regional Park, Sonoran Desert National Monument and the Hohokam Pima National Monument (See Exhibit C: Open Space Context Map).*
- *Planned trail corridors are located along the Peters & Nall Road alignment north of the site and John Wayne Parkway east of the site (See Exhibit C: Open Space Context Map) which could enhance further connectivity to the neighborhood. An internal trail system is provided throughout the community.*
- *The intended target market designation is 'Family' as defined in the OSRAM. As a development of 554 lots, Venida falls between the category of "All Developments", and "Developments Exceeding 1,000 Dwelling Units"*
- *The site consists of agricultural fields and slopes from the southwest to the northeast at approximately 0.4%. The property is considered disturbed, vacant land. (See Exhibit E: Site and Slope Analysis Plan)*
- *No natural washes exceeding 200 CFS were observed within the project that would require conservation. The wash on the southern boundary only conveys 155 cfs. The project site falls within Zone "X", which is defined by FEMA as "Areas determined to be outside the 0.2% annual chance of floodplain."*
- *An archaeological record search with the Arizona State Museum was completed (See Exhibit R: Cultural Resources Summary Letter) and eight archaeological surveys have been previously conducted within this study radius with one of the surveys conducted within the project area. No archaeological sites were found present within one mile of the project. The report recommends, but does not require, that an archaeology consultant survey the site prior to construction. The report also recommend, but does not require, the property to be re-surveyed when the previous survey work was done 10 or more years ago.*
- *The site is undeveloped agricultural land previously utilized for farming and no riparian vegetation, biological habitats and only 2 native plants are located on the property. There are no protected native plants on the site. Refer to Exhibits G & H for Native Plant Inventory and Native Plant List for each tree and intent.*

2. Site Plan

Venida is a single family residential development comprised of 158.25 acres with proposed typical lot sizes of 45' x 120' and 55' x 120'. While the current proposed plan provides 544 lots and an estimated density of 3.44 du/ac, the maximum number of lots permitted for the project is 554 lots per the approved gross density of 3.50 du/ac. (See Exhibit I: Proposed Site Plan). Final lot counts, density, and individual parcel data are subject to change and will be determined during the Tentative Plat and Final Plat processes. Minimum Open Space is outlined in the following table:

Category (for 0-5% slope)	Area Required	Area Provided
Conservation Open Space	0 acres	0 acres (all disturbed - farm)
Developed Open Space	18% (28.48 ac)	28.48 acres (18%)
Recreation Open Space	7% (11.10 acre)	11.10 acres (7%)
Total Open Space¹		28.48 acres

¹“Total Open Space” is the combination of conservation and developed open space.

Developed open space includes recreation open space.

The site has less than 5% slope and is disturbed land. Therefore, conservation open space is not provided per the open space requirements for disturbed conservation open space (0%). A minimum of 28.48 acres is proposed for developed open space, comprising landscape tracts, streetscape frontage, and recreational area open space.

A total of 14.62 acres of recreational open space has been proposed. The single-family residential lots within Venida shall benefit from accessible, dedicated recreational open space, centrally located in the community per county requirements for residents' equitable proximity. Amenity areas shall meet the appropriate level of recreation designated by Pinal County, including, at minimum, pathways in addition to sidewalks and inclusion of turf fields, a play structure and picnic ramada accessible to each parcel. Additionally, individual amenities are proposed to give further character to each of the central recreation areas, such as picnic areas, multi-use fields, gardens, or passive play games such as cornhole or bocce. Other open space areas within the proposed community will include concrete sidewalks, offering connectivity to the various central open spaces, and additional amenities as illustrated on the Open Space and Amenities Plan provided as Exhibit J and the Main Park Conceptual Landscape Plan provided as Exhibit M.

Pedestrian circulation within Venida will be provided by sidewalks and open space pathways. Circulation along the local streets will occur on sidewalks adjacent to curb. Connections to the open space areas from these attached sidewalks will be provided by pathways that meander through the open space. All paved access routes shall meet ADA guidelines (See Exhibit P: Landscape Master Plan).

3. Compliance with County Standards

A detailed review of the Pinal County Open Space and Recreation Area Manual (OSRAM) and the Pinal County Development Services Code (PCDSC) were undertaken to ensure development of this project would be in conformance with those guidelines and standards. A detailed analysis of this project's compliance is provided in Section D of this report. It was determined that this project is in conformance with the open space requirements, landscaping density requirements, and level of recreation amenity required.

4. Integration with the County's Open Space

Venida will be an integrated part of the surrounding community. Design Character, including walls, entry monuments, and amenities will be based on the design established by the existing plans approved for the original Venida community in 2006. Materials have been refined to be lower maintenance while still maintaining the established 2006 aesthetic.

B. Existing Conditions, Context, and Site Analysis

1. Project Context: Site Description

The Venida property is at present vacant as an undeveloped parcel of land, previously utilized for farming. The property is currently designated as Moderate Low Density Residential (MLDR, 1-3.5 du/ac.) use and is currently zoned as CR-3 and CB-1 Planned Area Development (PAD). A rezoning application to update the prior CB-2 parcel to R-7 and a major PAD amendment is in process as case #: PZ-PD-042-21.

The proposed Venida development lies at the southeast corner of Papago Road and Green Road in Pinal County, Arizona. Specifically the property encompasses a portion of land located in the Northwest Quarter of Section 21 in Township 5 South, Range 3 East of the Gila and Salt River Base and Meridian, Pinal County, Arizona. The Location Map is attached as Exhibit B and provides detailed information on the project's location and surrounding street alignments.

2. Project Context: Regional Location

The proposed Venida community lies at the southeast corner of Papago Road and Green Road in Pinal County, Arizona. Specifically the property is a portion of land Northwest Quarter of Section 21 in Township 5 South, Range 3 East of the Gila and Salt River Meridian, Pinal County, Arizona. The Maricopa (Ak-Chin) Reservation is located within one mile of the property and the City of Maricopa is located approximately 3 miles to the north of the site.

Regionally, the following highways provide access to surrounding communities.

- Maricopa - Casa Grande Highway: *Venida is 4 miles southwest of the Maricopa-Casa Grande Highway, which provides direct access to the City of Casa Grande located southeast of the community.*
- Interstate 10: *Venida is approximately 6 miles south of interchange via John Wayne Parkway and Papago Road. This in effect creates a direct route from the Venida community to the interstate, which in turn allows regional links to metro Phoenix and further outlying communities.*
- Interstate 8: *Venida is approximately 7 miles north of this interstate.*

The Property is accessed from the South via Papago Road from the North and Green Road from the west. Via de Ventura is classified as a Regionally Significant Route (RSR) Parkway accordingly to Pinal County's Regionally Significant Routes for Safety and Mobility (RSRSM) plan. Considerations required for the RSR Parkway classification will be made as determined per Pinal County Standards and Staff recommendations.

3. Surrounding Recreation Opportunities

A study of the surrounding area was performed, and the information compiled into the attached Open Space Context Map (See Exhibit C: Open Space Context Map), and the site analysis summary. Nearby parks were identified that will support the proposed development, including Palo Verde Regional Park, Sonoran Desert National Monument and the Hohokam Pima National Monument . These existing opportunities were considered in designing the open space program.

4. Project Context: Existing Connectivity and Area Trails

Review of the County's Open Space and Trails Master Plan (2007) and the County's online interactive GIS maps indicated that planned trail corridors are designated approximately one mile to the east along John Wayne Parkway and approximately one mile to the north along the Peters & Nall Road alignment. (See Exhibit C: Open Space Context Map)

These trail corridors are distant but careful consideration of the project design has been made to integrate them by providing access to the adjacent perimeter streets that connect to these designated corridors. Venida presents an opportunity for regional recreation linkages by providing detached sidewalks and bike lanes as part of the proposed improvements for these sections of Papago Road and Green Road, per County street cross-sections for a minor arterial road. These connections and internal pathways are addressed further in the implementation section of this report. (Refer to Section C.1.c: Implementation, Development Concept, Pedestrian Circulation Concept)

5. Target Market

Venida is proposed as a single family residential development. The site is generally flat and from visual analysis with prior agricultural use. This, coupled with the intent that the development is not targeted as an adult community, exclude it from the OSRAM designation of a ‘natural’ community.

Based on these factors, and the intended target market as a single family development, the designation of ‘Family’ as defined in the OSRAM is applicable to the project, and recreational amenities should approach National Recreation and Park Association (NRPA) standards. As a development permitting up to 554 lots, Venida falls between the category of “All Developments”, and “Developments Exceeding 1000 Dwelling Units, as defined in Table 1 of the OSRAM. Recreational amenities for Venida should exceed the first category, and include elements of the second category, as shown below, to be in conformance.

All Developments	Developments Exceeding 1000 Dwelling Units
Paths in addition to sidewalks	Paths in addition to sidewalks, One Acre Turf Field, One Play Structure, One Picnic Ramada

6. Site and View Shed Analysis

As the site has no significant topography, the views are offsite. Table Top Mountain is located south of the community and, with the highest peak in the area and its flat-topped summit of 4,373 feet, the mountain provides particularly notable view opportunities. Pedestrian connectivity running north-south throughout the community will optimize this viewshed to provide maximum scenic viewing opportunities. (See Exhibit E: Site and Slope Analysis Plan)

7. Slope Analysis

Analysis of existing slope is critical in determining the lands of high value, view sheds, and lands that should be set aside for conservation. Slopes exceeding 15% are generally set aside as conservation areas. Additionally, slope is used in determining the overall project requirement for Conservation Open Space and Recreation Area Open Space. The site is disturbed and has less than 5% slope across the site. No hillside is present to be conserved. (See Exhibit E: Site and Slope Analysis Plan) Calculations for the required Conservation Open Space and Recreation Area Open Space are based on the 0-5% slope, as determined in the table below:

Open Space Requirement Calculation				
Slope Categories	0% - 5% Slope	<5% - 10% Slope	<10% Slope	TOTALS
Measured Areas Within Each Category	158.25 acres	0 acres	0 acres	158.25 acres
Conservation Open Space Required	Min Req'd. = 0%/3% Area Req'd. = 0 acres	Min Req'd. = 5% Area Req'd. = 0 acres	Min Req'd. = 9% Area Req'd. = 0 acres	0 acres
Recreation Open Space Required	Min Req'd. = 7% Area Req'd. = 11.10 acres	Min Req'd. = 6% Area Req'd. = 0 acres	Min Req'd. = 4% Area Req'd. = 0 acres	11.10 acres
Total Open Space Required	Min Req'd. = 18% Area Req'd. = 28.48 acres	Min Req'd. = 18% Area Req'd. = 0 acres	Min Req'd. = 18% Area Req'd. = 0 acres	28.48 acres

8. Preliminary Hydrology Analysis

Venida is bordered on the north by Papago Road, on the south and east by agricultural fields and on the west by Green Road. The property consists of agricultural fields and slopes from the southwest to the northeast at approximately 0.4%.

The site contains moderate vegetation and is not located within any part of a regulated floodplain. No natural washes exceeding 200 CFS were observed within the project that would require conservation. (See Exhibit F: Preliminary Hydrology Analysis - Proposed Drainage Map)

9. Flood Zone Designation

The Pinal County, Arizona and Incorporated Areas Flood Insurance Rate Map (FIRM), Map Number 04021C1125E, Map Revised December 4, 2007, indicates the property falls within Zone X. Zone X is defined by FEMA as: "Areas of 0.2% annual chance flood; areas of 1% annual chance flood with average depths of less than 1 foot or with drainage areas less than 1 square mile; and areas protected by levees from 1% annual chance flood."

10. Archaeological Sites Investigation

A review was conducted of the AZSITE database maintained by the Arizona State Museum to identify previous archaeological investigations and recorded archaeological sites within a one mile radius of the project area. These records indicate that eight archaeological surveys have been previously conducted within this study radius between 1982 and 2009. One of these archaeological survey projects was conducted within the project area in 2009. This survey identified no recorded archaeological sites within the project area and no archaeological sites have been identified within a one-mile radius of the project. The report recommends, but does

not require, that an archaeology consultant survey the site prior to construction. (See Exhibit R: Archaeological Records Search Results)

11. Existing Vegetation and Biological Habitat Analysis

The site is composed entirely of previously disturbed area. In reviewing the Pinal County Open Space and Trails Master Plan (OSTMP), the site is located in an area of low-quality habitat value with no designated critical habitat present. According to the OSTMP, neither native grassland nor conservation areas are present on the site or in the adjacent area.

The site is undeveloped agricultural land previously utilized for farming and there are minimal protected native plants on the site. Refer to Exhibits G & H for Native Plant Inventory and Native Plant List for each tree and intent.

C. Implementation: Proposed Development Plan

1. Development Concept

a. Site Plan and Open Space Data

Venida is proposed as a single family residential community projected to contain approximately 544 single family lots with typical lot sizes of 45' x 120' and 55' x 120' for a density of 3.44 du/ac and permitted for up to 3.50 du/ac. The site is accessible from Papago Road and Green Road on its north and west perimeters.

Venida shall have a minimum of 18% of developed open space distributed throughout each of the parcels with recreation open space as defined within the PAD ordinance. (See Exhibit I: Proposed Site Plan) As noted in the Open Space and Amenities Plan provided as Exhibit J, there is a total of 28.48 acres of open space, or 18% of the project. The developed open space areas identified include landscape tracts, streetscape frontage, and recreational area open space.

Recreation open space within the developed open space shall include 11.10 acres minimum of open space consisting of tracts containing a minimum of 0.25 acres with the required street frontage and trees planted as designated by the County. Amenities are programmed to meet the "Family" designation for suitable amenities. Proposed amenity areas shall meet the "Family" level of recreation as designated by the County, including at minimum a pathway in addition to sidewalk and an additional one acre of turf field, a play area (minimum 60 feet in diameter) and/or picnic ramada (minimum 16' x 16') per OSRAM where possible. Individual amenities are proposed to give further character to each of the central recreation areas, such as picnic areas, multi-use fields, gardens, or passive play games such as cornhole or bocce.

The table below provides the required and provided open space acreage for the PAD per the appropriate slope category. The site fits within the category of 0-5% slope.

Category (for 0-5% slope)	Area Required	Area Provided
Conservation Open Space	0 acres	0 acres
Developed Open Space	18% (28.48 ac)	28.48 acres (18%)
Recreation Open Space	7% (11.10 acres)	11.10 acres (7%)
Total Open Space ¹		28.48 acres

¹ “Total Open Space” is the combination of conservation and developed open space. Developed open space includes recreation open space.

b. Vehicular Circulation Concept

The parcel has convenient access from Papago Road to the north and Green Road to the west. Papago Road and Green Road are classified as arterials. Proposed improvements for these roads are to be determined per Pinal County Standards. An interior collector roadway system is proposed for the community in order to discourage excessive traffic within the residential parcels.

Transportation improvements and open space areas are arranged in the community to provide connections throughout the planned neighborhoods. Streets and thoroughfares are proposed with the suitability and adequacy to serve the proposed uses and the anticipated traffic has been accommodated through the use of appropriately designed streets. Roundabouts, T-intersections, knuckles and curvilinear streets have been designed in order to slow traffic and add interest throughout the community. The potential neighborhood parks and trail system will be easily accessible from the collectors or neighborhood streets. All streets are to be built per Pinal County Standards and Staff recommendations. (See Exhibit I: Proposed Site Plan)

c. Pedestrian Circulation Concept

Pedestrian circulation within the development will be provided by sidewalks, open space paved and/or unpaved pathways per Pinal County standards. Circulation along the local streets will occur on sidewalks adjacent to curb. Connections to the open space areas from these attached sidewalks will be provided by pathways that meander through the open space. All paved access routes shall meet ADA guidelines. (See Exhibit J: Open Space and Amenities Plan)

d. Stormwater Management Concept

According to the Venida Master Drainage Report, project stormwater will be managed through surface flow on street, and a series of small channels that direct the flow to several distributed retention basins. Basins will be developed in accordance with County standards, and shall be comprised of side slopes that vary and range from 4:1 to 10:1. Retention basins have been designed to be compatible with recreation uses and will integrate paved pathways and picnic areas. Additionally, 25% of the recreation area within the basins will be maintained outside the basins high water level. (See Exhibit F: Preliminary Hydrology Analysis - Proposed Drainage Map)

e. Development Phasing Concept

The Venida community is to be developed in two phases. All common areas and open space amenities will be developed along with the parcel they are located in. Utilities and infrastructure will connect to all parcels through the development of Venida Parkway South, a collector centrally located within the property. The community has been planned to be flexible in design in order to respond to market demands/trends. A phasing plan is attached as Exhibit S.

In accordance with the OSRAM and County Standards, each phase of development will include a recreational open space area. Also, as outlined in the OSRAM, “At minimum, 33% of the larger centralized recreation area amenities should be constructed and operational by the time 25% of the of the total allowable dwelling units have had a final inspection, 66% of the larger centralized recreation area amenities should be constructed and operational by the time 50% of the of the total allowable dwelling units have had a final inspection, and 100% of the larger centralized recreation area amenities should be constructed and operational by the time 75% of the of the total allowable dwelling units have had a final inspection.”

2. Conservation Open Space

Conservation open space is not provided as the land has been previously disturbed. (See Exhibit J: Open Space and Amenities Plan)

3. Developed Open Space

a. Developed Open Space Areas

A total of 28.48 acres is developed open space. The developed open space areas are comprised of landscape tracts, streetscape frontage, and recreational area open space. (See Exhibit J: Open Space and Amenities Plan)

b. Proposed Entry, Walls, and Signage.

Proposed wall types shall provide a visually pleasing sense of community character, providing a cohesive uniformity across the parcels while maximizing open views and an interesting patterning of wall color and texture. Project signage will be provided in optimal locations at entries for ease of way-finding. A thematic monument with ground signage will be provided at the Papago Road entry and at the Southern most entry. Wall and sign locations and elevations have been illustrated in detail on the following exhibits: Wall and Signage Plan (Exhibit K), the Primary Entry Elevation (Exhibit N) and Secondary Entry and Wall Elevations (Exhibit O).

4. Recreation Area Open Space

A total of 15 acres of recreational open space has been designated. (See Exhibit J: Open Space and Amenities Plan) Proposed amenity areas shall meet the “Family” level of recreation as designated by the County, including at minimum a pathway in addition to sidewalk and an additional one acre of turf field, a play area (minimum 60 feet in diameter) and/or picnic ramada (minimum 16’ x 16’) per OSRAM where possible. Individual amenities are proposed to give further character to each of the central recreation areas, such as a BBQ grilles, picnic areas, pollinator gardens with water harvesting, multi-use fields, or passive play games such as cornhole and bocce.

As discussed in Section 5, Target Market, recreational amenities should fall between the following two categories. An analysis of the amenities provided is shown below.

Suggested Amenities for All Developments (Per OSRAM)	Suggested Amenities for Developments Exceeding 1,000 Dwelling Units (Per OSRAM)	Proposed Amenities (Up to 554 Dwelling Units)
Paths in addition to sidewalks	Paths in addition to sidewalks, one acre turf field, one play structure, one picnic ramada	Paths in addition to sidewalks, 0.5 acre turf multi use field, 2 play structure areas, 2 large group picnic ramadas with grilles. Small community parks with various activities and 3 small group ramadas with grilles. Additional turf open space areas, and trail nodes with pollinator gardens, natural shade and seating.

5. Landscaping

a. Landscape Character

The plants for the developed open space and streetscape will be selected to create an appropriate landscape palette, drawing from the property’s former agrarian usage while meeting ADWR low-water use criteria. Larger-canopy trees shall be planted with the intent to shade sidewalks and provide comfort for pedestrians, with emphasis on providing shaded western and southern exposures. Where space allows, trees over 30’ feet will be used to provide shade and low maintenance shrubs will be specified in hard to access areas. Distinct theme trees will be proposed to provide character in the central amenity areas and entries. The overall planting style will be naturalized, with trees clustered at focal points and access points. Native plants have been specified and will be prioritized where appropriate across the site. As discussed with town reviewer, turf quantities have been minimized and large expanses will be covered with a mix of decomposed granite, native seed mix, and shrubs.

b. Landscape Calculations

Landscaped tracts shall be planted in conformance with the OSRAM and County Standards. The table below outlines the required plant quantity, density and sizes for this development, and the amount provided. The calculations are based on the minimum 28.48 acres of developed open space. The quantities shown are the minimum required per Pinal County Development Services Code. Detailed calculations will be provided with the final landscape plans.

BASED ON 40.08 Acres (1,845,884 SF)	Total Trees (15 Gallon Minimum)	24" Box Trees	Shrubs (5 Gallon Minimum)	Groundcover (<18" tall)
Standard / Requirement	1 per 1000 SF	25% of tree total	7 per 1000 SF	>50% of vegetation area
Calculation	1,240,768/1,000	0.25 x 1,241 trees	(1,240,768/1,000)x7	(1,241 trees x 400 SF = 496,400 SF) + (8,686 shrubs x 18 SF = 156,348 SF) Total (652,748) x 50%
Quantity Required	1,241 trees	311 - 24" box	8,686 shrubs	326,374 SF of Groundcover

c. Irrigation Source

To minimize landscape irrigation demand, all plants will be low water use, per the ADWR plant list. Passive rainwater harvesting techniques will be utilized in the developed open spaces to direct rain water towards the clustered tree stands.

The irrigation source will be potable water, with connection points being water meters located within the open space tracts, and to be coordinated with the civil plans.

D. Compliance with County Guidelines and General OSRP Design Guidelines

1. Conformance to the Open Space and Recreation Area Manual (OSRAM)

The development team has reviewed the Open Space and Recreation Area Guideline Manual. Key design guidelines are quoted directly from the manual, below. These guidelines are then related to the proposed development. The development standards outlined in this plan are in conformance with the OSRAM, as follows:

Spatial Standards

“Open space should be located and designed as a community amenity and provided with each phase of a development. It should be highly visible to the public to encourage community use and awareness.”

Each parcel of the Venida community shall be provided with open space on the largest and/or most central tract within the parcel and access to an amenity area. The design of the amenity and open space areas shall maximize views into the area with site lighting and clear access routes to encourage safe, appealing, and accessible community use. The main amenity area is centrally located within the community.

“A good measure of accessibility is providing recreation areas and multi-use paths and trails within a 1,000-foot radius from each dwelling unit.”

The parcel layout for this development was designed to meet this standard. The dwelling units within each parcel are within a radius of approximately 1,000’ to the main park, one of the five pocket parks with picnic ramadas and various activities or the linked trail system throughout.

“Arterial Street Frontage: meandering tract between 15 and 20 feet in width”

The proposed development is adjacent to Papago Road and Green Road, arterial streets. The landscape tracts along these streets range from 43’ to well over 200’, providing a generous landscape buffer and entry into the development. Furthermore, large open space tracts have been provided along the internal collector road with visually-pleasing landscape appeal to provide interest along interior sidewalks.

Groundform

Retention basins “should be shaped to have meandering edges with varying slide slopes from 4:1 to 10:1.”

“Contouring of the ground and placement of mounds and earth berms along streets is recommended.”

“Retention/detention basins designated as developed open space should be located so that they are visible, attractive, and accessible.”

All retention basins will have varying side slopes in conformance with the OSRAM. The grading plans will be coordinated with the landscape design to ensure flowing transitions and ADA access to the open space area. All retention or detention basins in open space tracts shall be designed in a naturalized, attractive and accessible form.

Planting Standards

“a) a minimum of fifty percent (50%) vegetative groundcover that does not exceed eighteen (18) inches in height, and b) no more than fifty percent (50%) trees and shrubs.”

“Provide a natural native desert (or regionally compatible) plant pallet of trees, shrubs and ground covers grouped and arranged to create interesting patterns and textures.”

“Shrubs with a minimum size of five (5) gallons should be planted at a rate of five (5) shrubs per thirty (30) feet of linear street frontage.”

“A minimum of twenty-five (25) percent of all frontage landscaped areas should be covered with vegetative or organic groundcover consisting of living plant materials characterized by horizontal”

“Clustering of trees and shrubs is encouraged to accent focal points or landmarks and to provide variety to the streetscape.”

The plant palette and planting design has been developed in conformance to the OSRAM. Groundcover shall be balanced in quantity with trees and shrubs. Trees, shrubs and groundcovers shall be planted in naturalized clusters and provide color in variation with the seasons. Meandering landscape tracts along street frontages shall be planted in conformance with these design standards and clustering of accent and theme trees will further enhance the variety and focal areas along streetscapes and open space tracts. All plants used will be from the ADWR low water use list for Pinal County. Final planting design will conform to the densities established in the OSRAM.

Planting density calculations were provided within this document that verify conformance with quantities and density requirements.

Conservation Areas

“Conservation areas should be contiguous to any existing or planned conservation area located adjacent to the proposed development.”

“The fragmentation of conservation lands is strongly discouraged.”

The site was analyzed for conservation potential and determined that as the land has been previously disturbed and is quite flat without hillside, conservation area shall not be provided in accordance with the County requirement for a disturbed area.

Recreation and Amenities

“Seating areas should be located in appropriate locations to provide supervision of activities. Seating areas shall incorporate shade.”

“All recreation areas within the development should be connected through a multi-use path or trail system.”

Venida falls between the category of “All Developments”, and “Developments Exceeding 1000 Dwelling Units”, as defined in Table 1 of the OSRAM. Recreational amenities for Venida should exceed the first category, and include elements of the second category, as shown below, to be in conformance.

All Developments	Developments Exceeding 1000 Dwelling Units
Paths in addition to sidewalks	Paths in addition to sidewalks, One Acre Turf Field, One Play Structure, One Picnic Ramada

The proposed development exceeds these minimum standards with two play structure areas, two large group picnic ramadas at the main park. Three small group ramadas, various activities such as ball courts and/or multi-use fields, and additional turf at open space areas and pocket parks. In addition, seating nodes with tree shade are provided along the paths and trails throughout the community to provide pleasant and comfortable outdoor enjoyment. Pathways shall connect the amenities to nearby sidewalks for ease of access within and between parcels.

Pathway and Trail Guidelines

“Suburban Trails have a high to moderate intensity usage and are located in mixed use, commercial, residential, and office areas. They can be either paved or unpaved. The typical suburban trail users may include pedestrians, bicyclists, equestrians, and in-line skaters...Suburban trails link recreation areas and open space areas and adjacent community developments, and serve both recreation and transportation needs.”

“Trails need to be easily accessible to the public for the trails to receive high use.”

“The pedestrian circulation system should efficiently connect all open spaces and recreation areas in the proposed development in a manner that meets the objectives of the OSRP plan.”

“Trail design should be incorporated into plans for natural drainage channels, street rights-of-way, landscape corridors, utility rights-of-way, levees, and other open spaces.”

The Venida community provides a trail system that is consistent with the requirements identified in the OSRAM. The projects’ proposed zoning, per the PAD, matches the suburban trail designation and the target market analysis further indicates the community’s trails will be effectively used by future residents, with ease of access between the parcels’ open space tracts and the 8’ wide detached sidewalks and bike lanes along Papago Road and Green Road. (See Exhibit C: Open Space Context Map; Refer to Section C.1.c: Implementation, Development Concept, Pedestrian Circulation Concept)

2. Conformance to the PCDSC

The development standards outlined in this plan are in conformance with Chapter 2.176 of the PCDSC, as follows:

Section 130 – Minimum requirements for open space

The average slope for the net acreage of the project is less than 5%, requiring a minimum of 0% conservation open space if disturbed (3% min. if undisturbed), a minimum of 7% recreation open space, and a total of 18% open space. The proposed development meets these criteria as follows:

Open Space Requirements for PAD with <5% slope avg.	Minimum Required	Proposed
Conservation Open Space	0% (disturbed)	0%
Recreation Open Space	7%	7%
Total Open Space	18%	18%

Section 140 – Uses Permitted

The proposed development provides pathways, recreation areas, entryways, streetscapes, and retention/detention areas within the developed open space, in conformance with the PCDSC.

Section 150 – Uses Prohibited

No prohibited uses are being proposed in the open space areas.

Section 160 – Minimum Requirements for Recreation Areas

The Phasing Plan provided as Exhibit S outlines the phasing for the proposed development. This phasing will be tied to the final plat. The phasing allows for development of the primary amenity area with the first phase of development. All recreation open space areas are located with direct access from the local streets and are centrally located to the development. The groundform of these areas will be varied and natural, with a minimum of 25% of the open space area out of the retention.

Plant sizes will meet or exceed the minimum standards. The total required and provided plant quantities are shown in Section C.5.b. Landscape Calculation.

Section 170 – Minimum Requirements for Multi-use Paths and Trails

Review of the County’s Open Space and Trails Master Plan (2007) and the County’s online interactive GIS maps indicated that planned trail corridors are designated approximately one mile to the east along John Wayne Parkway and approximately one mile to the north along the Peters & Nall Road alignment. (See Exhibit C: Context Map)

These trail corridors are distant but careful consideration of the project design has been made to integrate them by providing access to the adjacent perimeter streets that connect to these designated corridors. Venida presents an opportunity for regional recreation linkages by providing 8' wide detached sidewalks and bike lanes as part of the proposed improvements for these sections of Papago Road and Green Road, per County street cross-sections. A recreator could traverse between the trail system of the Venida community and the existing trail corridors referenced above by utilizing this street connection. (See Exhibit C: Context Map)

Section 180 – Minimum Requirements for Storm Water Retention and Detention Basins

As noted previously, the groundform of the open space area will be varied and natural. Trails through the open space will meet ADA guidelines. The appearance of retention basins will be softened with natural grading and berming along adjacent streets. Turf will be utilized in the basins where appropriate and in minimal amounts to conserve water. Open space areas will be provided with drought tolerant plant material.

Section 190 – Minimum Requirements for Streetscape and Entryways

Plant sizes and density will meet or exceed the requirements of the PCDS. All plant material used will be listed on the ADWR low water use plant list.

Section 200 – Minimum Requirements for Conservation of Open Space

Conservation open space is not provided in this PAD per County's requirements (0% conservation for disturbed land). The geologic fissure area shall receive a native revegetation treatment in line with the conservation principle of native species.

Aerial Map

Exhibit A



W PAPAGO RD

N GREEN ROAD

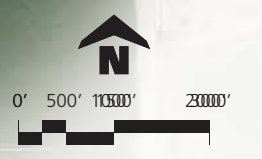

Vicinity Map

Exhibit B

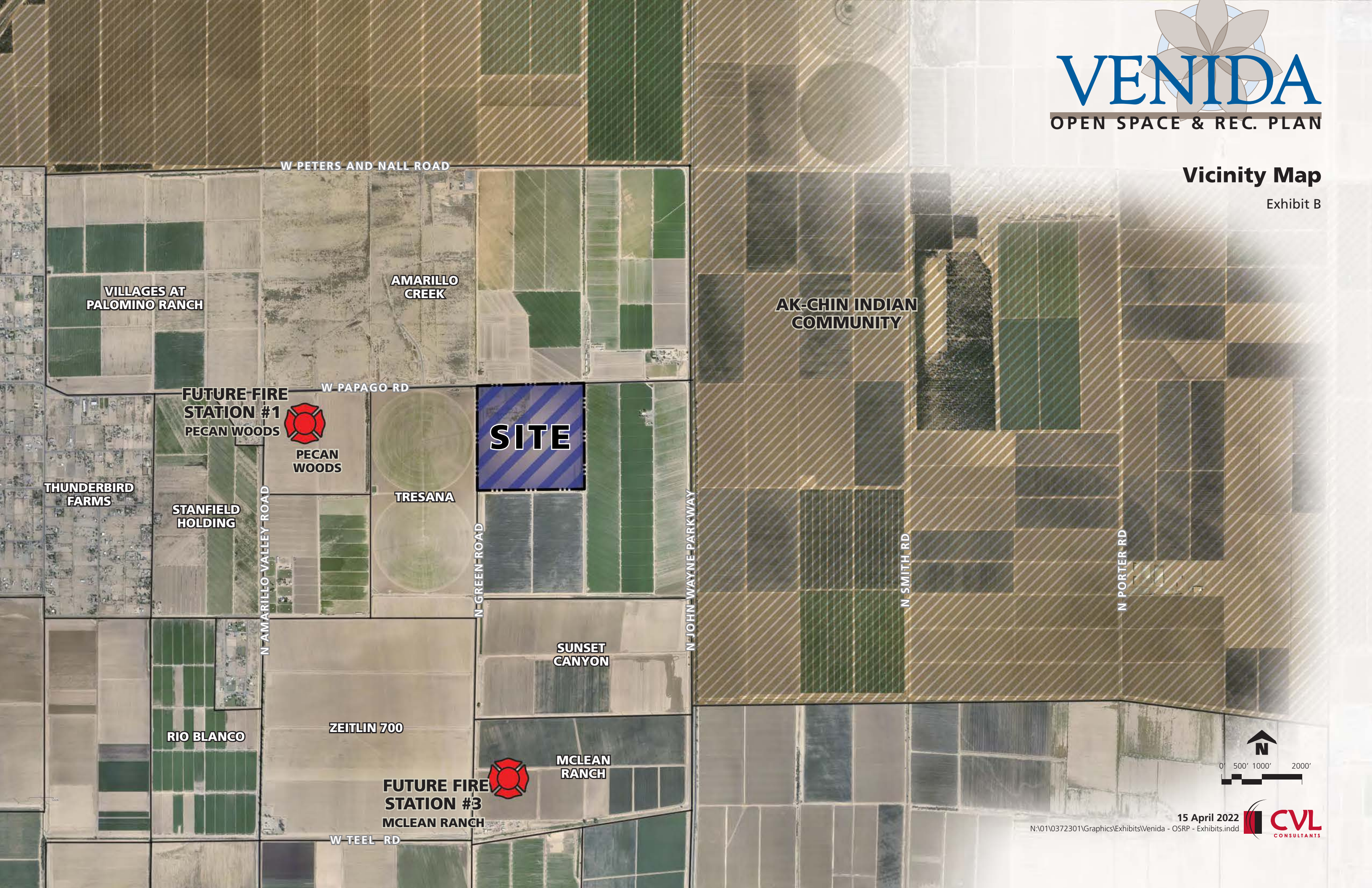









Context Map

Existing Zoning

Exhibit C.1

LEGEND
Pinal County Zoning



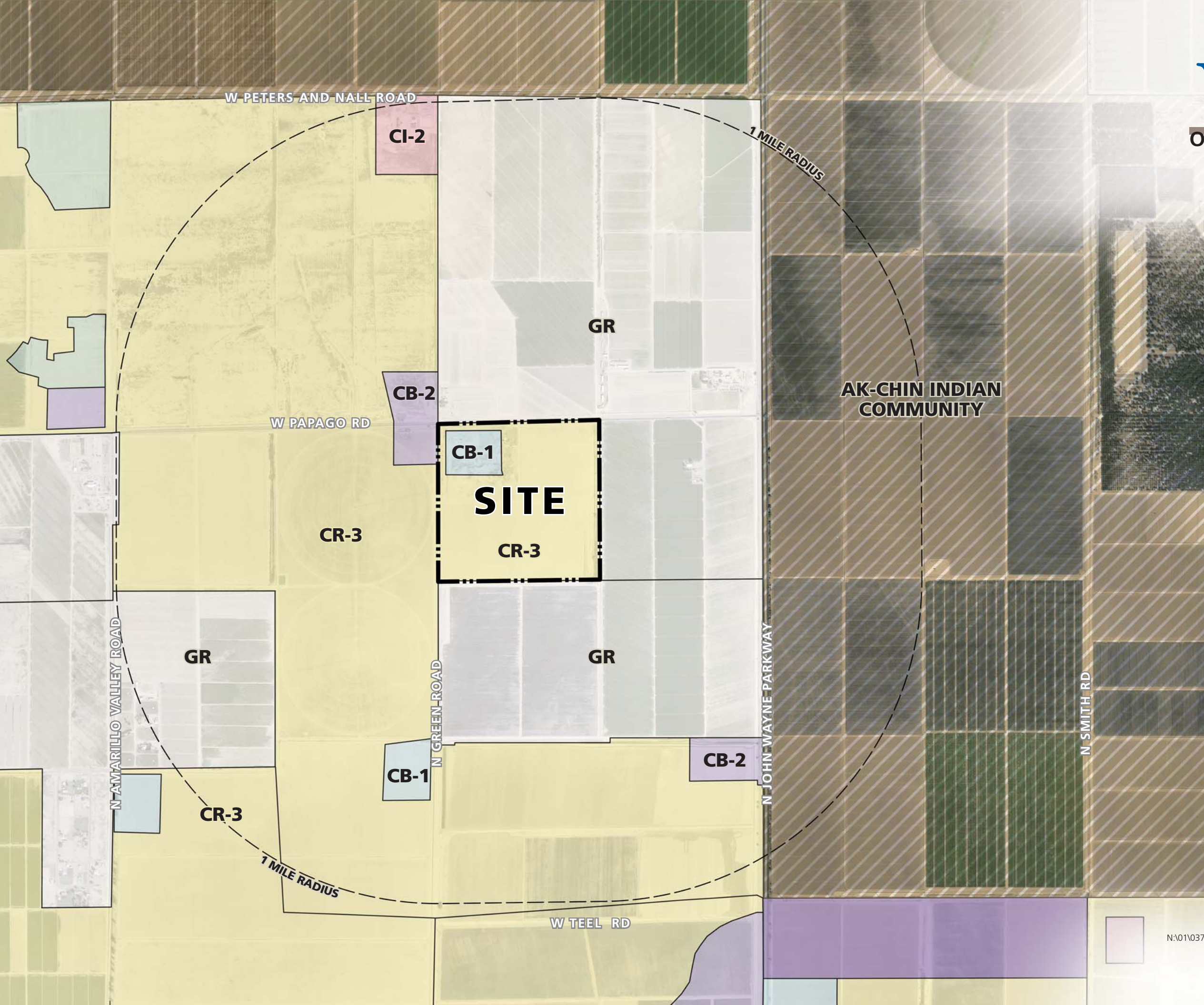







	CB-1
	CB-2
	CI-2
	CR-3
	GR General Rural
	Ak-Chin Indian Community
	Project Boundary
	1 Mile Radius



Context Map Connectivity

Exhibit C.2

LEGEND

-  Parkway
-  Future Parkway
-  Principal Arterial
-  Minor Arterial
-  Minor Arterial (Unpaved)
-  Pinal County Existing/Planned Multi-use Trail Corridor
-  Ak-Chin Indian Community
-  State Land
-  Future Fire Station
-  Project Boundary
-  1 Mile Radius



VENIDA

A.L.T.A./N.S.P.S. LAND TITLE SURVEY

A PORTION OF LAND LOCATED IN THE NORTHWEST QUARTER OF SECTION 21,
TOWNSHIP 5 SOUTH, RANGE 3 EAST, OF THE GILA AND SALT RIVER MERIDIAN,
PINAL COUNTY, ARIZONA

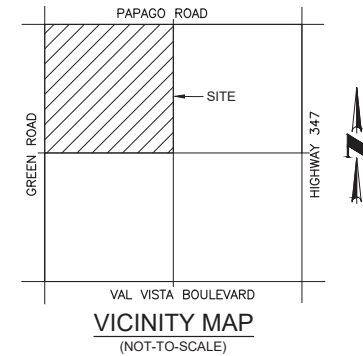

NO.	REVISION	DATE
1	ADDED ITEM 7 & 11. UPDATED PARCELS ON MAPPING SHEET	09/08/21
2	ADDED PROPOSED PHASING LINES ON MAPPING SHEETS	09/20/21
3	VERIFIED SITE CONDITIONS	10/14/21

Coe & Van Loo Consultants, Inc.

A.L.T.A. / N.S.P.S. LAND TITLE SURVEY

VENIDA
MARICOPA, ARIZONA

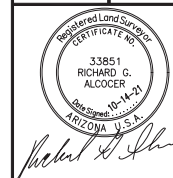

01 SHEET OF 03
CVL Contact: JERRY DODD
CVL Project #: 1-01-03723-01

© 2021 Coe & Van Loo Consultants, Inc. All rights reserved. No reproduction in any format.

NOTES

THIS SURVEY IS BASED ON A COMMITMENT FOR TITLE INSURANCE BY FIRST AMERICAN TITLE INSURANCE COMPANY.

ORDER NO. NCS-1075218-PHX1 DATED 06/24/2021

THE PROPERTY IS SUBJECT TO THE FOLLOWING, ACCORDING TO SCHEDULE B OF SAID COMMITMENT:

1. TAXES FOR THE FULL YEAR OF 2021. (THE FIRST HALF IS DUE OCTOBER 1, 2021 AND IS DELINQUENT NOVEMBER 1, 2021. THE SECOND HALF IS DUE MARCH 1, 2022 AND IS DELINQUENT MAY 1, 2022.)

2. ANY CHARGE UPON SAID LAND BY REASON OF ITS INCLUSION IN MARICOPA/STANFIELD IRRIGATION AND DRAINAGE DISTRICT. (ALL ASSESSMENTS DUE AND PAYABLE ARE PAID.) (NOT MAPPABLE)

3. ANY CHARGE UPON SAID LAND BY REASON OF ITS INCLUSION IN CENTRAL ARIZONA WATER CONSERVATION DISTRICT. (ALL ASSESSMENTS DUE AND PAYABLE ARE PAID.) (NOT MAPPABLE)

4. ANY CHARGE UPON SAID LAND BY REASON OF ITS INCLUSION IN CENTRAL ARIZONA GROUNDWATER REPLENISHMENT DISTRICT. (ALL ASSESSMENTS DUE AND PAYABLE ARE PAID.) (NOT MAPPABLE)

5. RESERVATIONS OR EXCEPTIONS IN PATENTS, OR IN ACTS AUTHORIZING THE ISSUANCE THEREOF. (NOT MAPPABLE)

6. A RESOLUTION BY THE BOARD OF SUPERVISORS OF PINAL COUNTY, ARIZONA, RECORDED FEBRUARY 21, 1964 AS DOCKET 375, PAGE 572, PURPORTING TO ESTABLISH A COUNTY ROADWAY. (AFFECTS ALL PARCELS) (MAPPED HEREON)

7. THE TERMS AND PROVISIONS CONTAINED IN THE DOCUMENT ENTITLED "AGREEMENT" RECORDED AUGUST 02, 1989 AS DOCKET 1622, PAGE 163 AND MODIFIED FEBRUARY 18, 1994 IN DOCKET 1984, PAGE 154. (AFFECTS PARCEL NO. 1) (ITEM IS BLANKET IN NATURE-NOT MAPPABLE)

8. THE TERMS AND PROVISIONS CONTAINED IN THE DOCUMENT ENTITLED "INFRASTRUCTURE COORDINATION AND FINANCE AGREEMENT" RECORDED AUGUST 18, 2005 AS 2005-0106214 OF OFFICIAL RECORDS AND RE-RECORDED OCTOBER 12, 2005 AS 2005-0139038 OF OFFICIAL RECORDS. (AFFECTS PARCEL NO. 1) (ITEM IS BLANKET IN NATURE - NOT MAPPABLE)

9. ALL MATTERS AS SET FORTH IN CASE NO. PZ-023-06 ZONE CHANGE RESOLUTION, RECORDED DECEMBER 22, 2006 AS 2006-0174394 OF OFFICIAL RECORDS. (AFFECTS ALL PARCELS) (ITEM IS BLANKET IN NATURE - NOT MAPPABLE)

10. ALL MATTERS AS SET FORTH IN CASE NO. PZ-PD-023-06 PLANNED AREA DEVELOPMENT (PAD) OVERLAY DISTRICT RESOLUTION, RECORDED DECEMBER 22, 2006 AS 2006-0174395 OF OFFICIAL RECORDS. (AFFECTS ALL PARCELS) (ITEM IS BLANKET IN NATURE - NOT MAPPABLE)

11. ALL MATTERS AS SET FORTH IN ASSIGNMENT OF ELECTRICAL UTILITY EASEMENTS, RECORDED AS 2010-092661 OF OFFICIAL RECORDS. (AFFECTS ALL PARCELS) (ITEM IS BLANKET IN NATURE - DOCUMENT CONTAINING SPECIFIC ASSIGNED EASEMENT NOT PROVIDED (DKT. 851, PG. 704) - DOES NOT AFFECT SURVEYED PARCEL)

12. THE TERMS AND PROVISIONS CONTAINED IN THE DOCUMENT ENTITLED "INFRASTRUCTURE COORDINATION AND FINANCE AGREEMENT" RECORDED AUGUST 18, 2005 AS 2005-0106216 OF OFFICIAL RECORDS AND RE-RECORDED OCTOBER 12, 2005 AS 2005-0139040 OF OFFICIAL RECORDS. (AFFECTS PARCEL NO. 2) (ITEM IS BLANKET IN NATURE - NOT MAPPABLE)

13. ALL MATTERS AS SET FORTH IN RECORD OF SURVEY, RECORDED AS BOOK 8 OF SURVEYS, PAGE 170. (AFFECTS PARCEL NO. 2) (MAPPED HEREON)

14. ANY CLAIM THAT THE TITLE IS SUBJECT TO A TRUST OR LIEN CREATED UNDER THE PERISHABLE AGRICULTURAL COMMODITIES ACT, 1930 (7 U.S.C. §§499A, ET SEQ.) OR THE PACKERS AND STOCKYARDS ACT (7 U.S.C. §§181 ET SEQ.) OR UNDER SIMILAR STATE LAWS. (AFFECTS PARCEL NO. 1) (NOT MAPPABLE)

15. ANY FACTS, RIGHTS, INTERESTS OR CLAIMS THAT MAY EXIST OR ARISE BY REASON OF THE FOLLOWING MATTERS DISCLOSED BY AN ALTA/NSPS SURVEY MADE BY _____ ON _____, DESIGNATED JOB NUMBER _____ (NOT MAPPABLE)

16. THE RIGHTS OF PARTIES IN POSSESSION BY REASON OF ANY UNRECORDED LEASE OR LEASES OR MONTH TO MONTH TENANCIES AFFECTING ANY PORTION OF THE WITHIN DESCRIBED PROPERTY. (NOT MAPPABLE)

17. WATER RIGHTS, CLAIMS OR TITLE TO WATER, WHETHER OR NOT SHOWN BY THE PUBLIC RECORDS. (NOT MAPPABLE)

PURSUANT TO TABLE "A", ITEM 1, MONUMENTS HAVE BEEN PLACED (OR A REFERENCE MONUMENT OR WITNESS TO THE CORNER) AT ALL MAJOR CORNERS OF THE BOUNDARY OF THE PROPERTY, UNLESS ALREADY MARKED OR REFERENCED BY EXISTING MONUMENTS OR WITNESSES IN CLOSE PROXIMITY TO THE CORNER.

PURSUANT TO TABLE "A", ITEM 2, THE PROPERTY ADDRESS IS UNAVAILABLE PER THE PINAL COUNTY ASSESSOR.

NOTES (CONTINUED)

PURSUANT TO TABLE "A", ITEM 3, FLOOD ZONE INFORMATION IS SHOWN IN THE FLOOD ZONE CERTIFICATION.

PURSUANT TO TABLE "A", ITEM 4, PARCEL AREAS ARE SHOWN AT THE END OF THE LEGAL DESCRIPTION.

PURSUANT TO TABLE "A", ITEM 8, SUBSTANTIAL FEATURES OBSERVED IN THE FIELD ARE SHOWN ON THE PLAT OF SURVEY.

PURSUANT TO TABLE "A", ITEM 13, NAMES OF ADJOINING OWNERS OF SUBDIVIDED LANDS ACCORDING TO CURRENT TAX RECORDS ARE SHOWN ON THE PLAT OF SURVEY.

PURSUANT TO TABLE "A", ITEM 16, THERE IS NO OBSERVABLE EVIDENCE OF EARTH MOVING WORK, BUILDING CONSTRUCTION OR BUILDING ADDITIONS WITHIN RECENT MONTHS.

PURSUANT TO TABLE "A", ITEM 17, THERE IS NO INFORMATION AVAILABLE CONCERNING ANY CHANGES IN STREET RIGHT OF WAY LINES, EITHER COMPLETED OR PROPOSED. THERE IS NO OBSERVABLE EVIDENCE OF RECENT STREET OR SIDEWALK CONSTRUCTION OR REPAIRS.

ADJOINING RIGHTS-OF-WAY ARE MAPPED PER INFORMATION FROM THE PINAL COUNTY ASSESSOR UNLESS NOTED OTHERWISE.

BEARINGS, DISTANCES AND CURVE DATA NOT SPECIFIED AS RECORD OR MEASURED REPRESENT CVL FIELD MEASURED DATA.

THIS SURVEY REFLECTS BLUESTAKE MARKINGS AS FOUND IN THE FIELD. THESE MARKINGS WERE NOT ORDERED BY CVL NOR THE CLIENT AND WERE SET BY UNKNOWN PARTIES FOR UNKNOWN PURPOSES.

SOURCES USED IN THE PREPARATION OF THIS SURVEY INCLUDE:
BOOK 8 OF SURVEYS, PAGE 170

LEGAL DESCRIPTION

PARCEL NO. 1:
THE NORTHEAST QUARTER OF THE NORTHWEST QUARTER AND THE SOUTH HALF OF THE NORTHWEST QUARTER OF SECTION 21, TOWNSHIP 5 SOUTH, RANGE 3 EAST OF THE GILA AND SALT RIVER MERIDIAN, PINAL COUNTY, ARIZONA.

PARCEL NO. 2
THE NORTHWEST QUARTER OF THE NORTHWEST QUARTER OF SECTION 21, TOWNSHIP 5 SOUTH, RANGE 3 EAST OF THE GILA AND SALT RIVER BASE AND MERIDIAN, PINAL COUNTY, ARIZONA.

PARCEL 1 CONTAINS 118.846 ACRES, MORE OR LESS
PARCEL 2 CONTAINS 39.399 ACRES, MORE OR LESS

FLOOD ZONE CERTIFICATION

THIS IS TO CERTIFY THAT THIS PROPERTY IS LOCATED WITHIN THE ZONE "X" FLOOD HAZARD AREA PER FIRM MAP PANEL NUMBER 04021C-1125 E DATED DECEMBER 4, 2007, AS PUBLISHED BY THE FEDERAL EMERGENCY MANAGEMENT AGENCY (FEMA).

ZONE "X" AS DEFINED BY FEMA IS:
AREAS OF 0.2% ANNUAL CHANCE FLOOD; AREAS OF 1% ANNUAL CHANCE FLOOD WITH AVERAGE DEPTHS OF LESS THAN 1 FOOT OR WITH DRAINAGE AREAS LESS THAN 1 SQUARE MILE, AND AREAS PROTECTED BY LEVEES FROM 1% ANNUAL CHANCE FLOOD.

BASIS OF BEARING

THE BASIS OF BEARINGS FOR THIS SURVEY IS NORTH 88°32'15" EAST ALONG THE NORTH LINE OF SECTION 21, TOWNSHIP 5 SOUTH, RANGE 3 EAST OF THE GILA AND SALT RIVER MERIDIAN, ACCORDING TO BOOK 8 OF SURVEYS, PAGE 170, PINAL COUNTY RECORDS.

CERTIFICATION

TO:
LGI HOMES - ARIZONA, LLC, AN ARIZONA LIMITED LIABILITY COMPANY;
HAM PAPAGO, L.L.C., AN ARIZONA LIMITED LIABILITY COMPANY;
FIRST AMERICAN TITLE INSURANCE COMPANY;

THIS IS TO CERTIFY THAT THIS MAP OR PLAT AND THE SURVEY ON WHICH IT IS BASED WERE MADE IN ACCORDANCE WITH THE 2021 MINIMUM STANDARD DETAIL REQUIREMENTS FOR ALTA/NSPS LAND TITLE SURVEYS, JOINTLY ESTABLISHED AND ADOPTED BY ALTA AND NSPS, AND INCLUDES ITEMS 1, 2, 3, 4, 8, 13, 16 AND 17 OF TABLE A THEREOF. THE FIELD WORK WAS COMPLETED ON 10/06/2021.

DATE OF PLAT OR MAP: 09/08/2021

RICHARD G. ALCO CER
REGISTRATION NUMBER 33851
4550 N. 12TH STREET
PHOENIX, ARIZONA 85014
(602)-264-6831
CVLSURVEY@CVL.CI.COM

Existing Conditions
Alta Survey
Exhibit D.1

VENIDA

OPEN SPACE & REC. PLAN

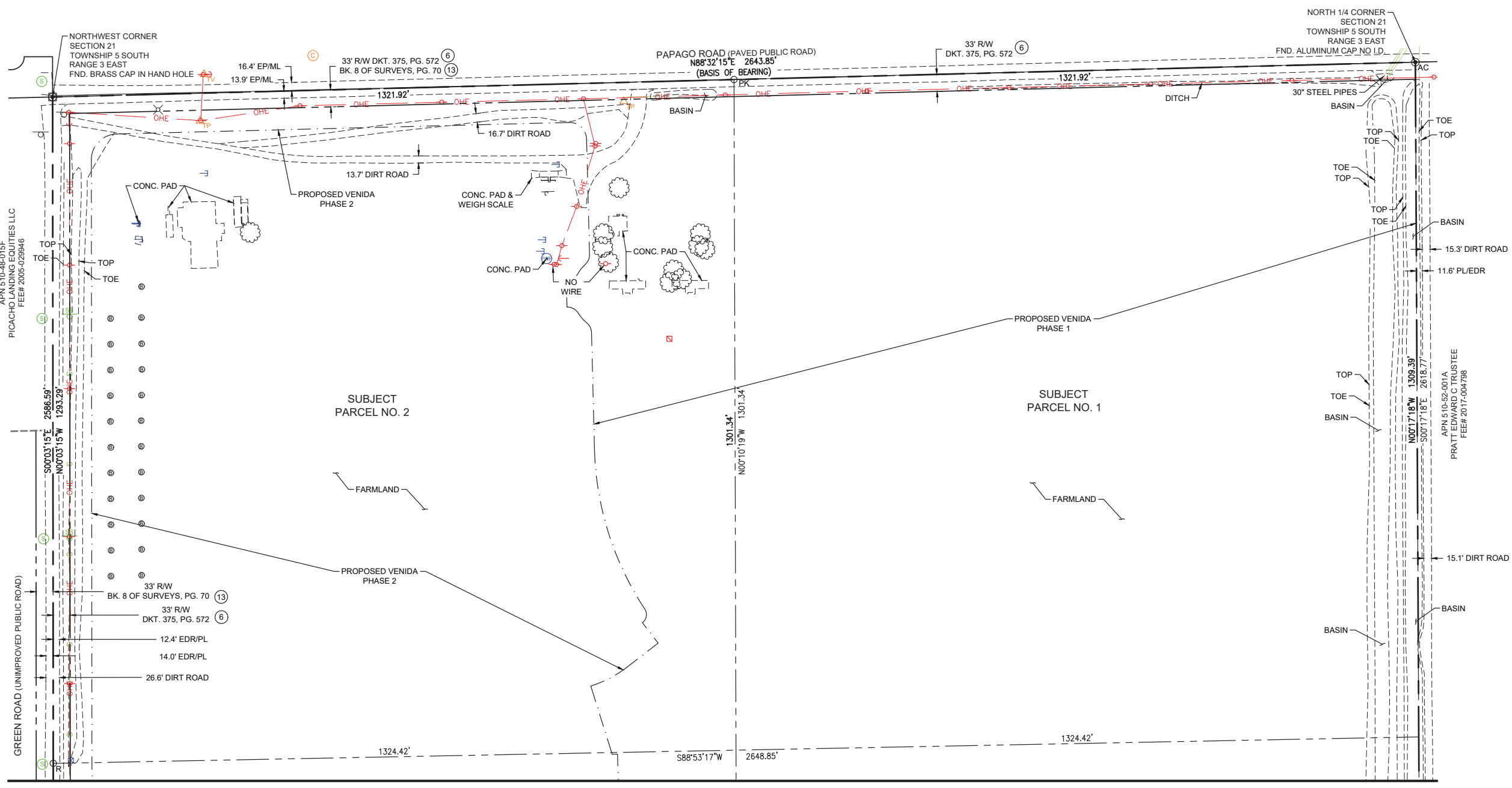

NO.	REVISION	DATE
1	ADDED ITEM 7 & 11. UPDATED PARCELS ON MAPPING SHEET	09/08/21
2	ADDED PROPOSED PHASING LINES ON MAPPING SHEETS	09/20/21
3	VERIFIED SITE CONDITIONS	10/14/21

Coe & Van Loo Consultants, Inc.

A.L.T.A. / N.S.P.S. LAND TITLE SURVEY

VENIDA
MARICOPA, ARIZONA

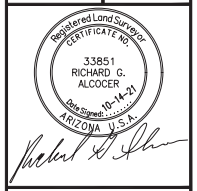

02 SHEET OF 03
CIVL Contact: JERRY DODD
CIVL Project #: 1-01-03723-01

LEGEND

APN	ASSESSOR PARCEL NUMBER	TOP	TOP OF SLOPE	⚡	POWER POLE	⚡ _P	TELEPHONE PEDESTAL
CONC.	CONCRETE	TOE	TOE OF SLOPE	⚡ _V	POLE STREET LIGHT	⚡ _V	CABLE TV PEDESTAL
CLD	CONCRETE LINED DITCH	○ _C	CALCULATED POSITION - NOTHING FOUND, NOTHING SET	⊠	ELECTRIC METER	●	BOLLARD
CMU	CONCRETE MASONRY UNIT	⊙	FOUND BRASS CAP FLUSH	⊠	WATER METER	⊙	WELL PUMP
ESMT	EASEMENT	⊙ _{AC}	FOUND BRASS CAP IN HAND HOLE	⊠	WELL PUMP	⊙	WELL PUMP
EP	EDGE OF PAVEMENT	⊙ _{AC}	FOUND ALUMINUM CAP	⊠	STUB OUT	⊙	STUB OUT
EDR	EDGE OF DIRT ROAD	● _R	FOUND REBAR	⊠	SIGN	⊙	SIGN
FND.	FOUND	●	FOUND IRON PIPE	⊠	TREE (GENERIC)	⊙	TREE (GENERIC)
ML	MONUMENT LINE	○ _{PK}	SET PK-NAIL WITH WASHER LS#33851	⊠	MANHOLE SANITARY SEWER	⊙	MANHOLE SANITARY SEWER
PL	PROPERTY LINE	○ _R	SET 1/2" REBAR WITH CAP LS#33851	⊠	SIGN - SEWER UNDERGROUND	⊙	SIGN - SEWER UNDERGROUND
RW	RIGHT-OF-WAY	←	DOWNGUY	⊠	MANHOLE COMMUNICATIONS	⊙	MANHOLE COMMUNICATIONS

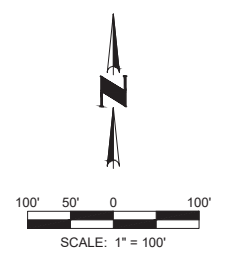

Existing Conditions
Alta Survey
Exhibit D.2

VENIDA
OPEN SPACE & REC. PLAN

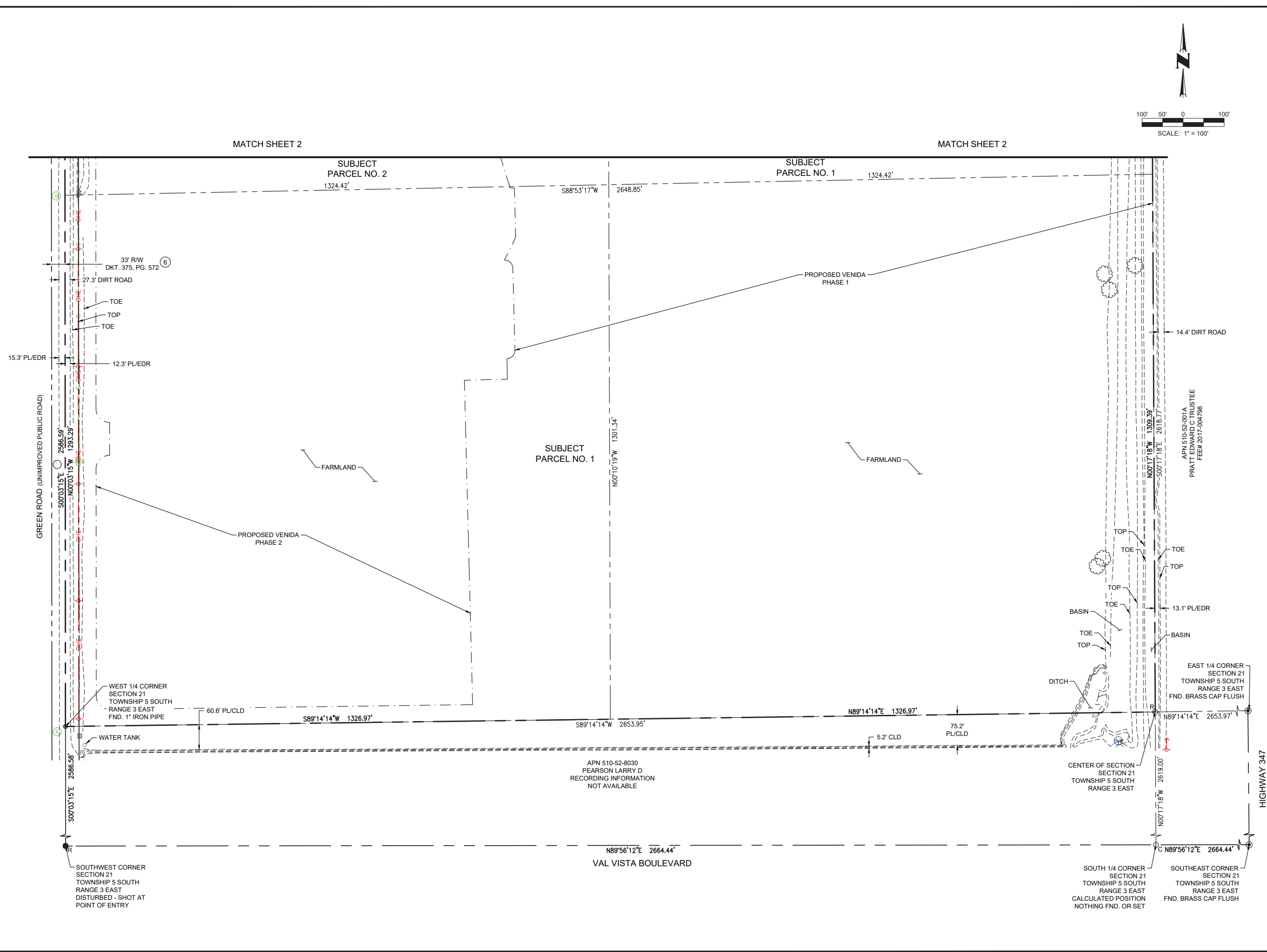

CVL CONSULTANTS
 CELEBRATING 60 YEARS
 4560 North 27th Street
 Phoenix, Arizona 85014
 602-264-9831
 www.cvl.com

VENIDA
 MARICOPA, ARIZONA

NO.	REVISION	DATE
1	ADDED ITEM 7 & 11. UPDATED PARCELS ON MAPPING SHEET	09/08/21
2	ADDED PROPOSED PHASING LINES ON MAPPING SHEETS	09/20/21
3	VERIFIED SITE CONDITIONS	10/14/21

A.L.T.A. / N.S.P.S. LAND TITLE SURVEY

VENIDA
MARICOPA, ARIZONA

PROPOSED VENIDA PHASE 1

PROPOSED VENIDA PHASE 2

GREEN ROAD (UNIMPROVED PUBLIC ROAD)

VAL VISTA BOULEVARD

HIGHWAY 347

APN 510-52-001A
PRATT EDWARD C TRUSTEE
FEE# 2017-004798

APN 510-52-8030
PEARSON LARRY D
RECORDING INFORMATION
NOT AVAILABLE

SOUTH 1/4 CORNER SECTION 21 TOWNSHIP 5 SOUTH RANGE 3 EAST DISTURBED - SHOT AT POINT OF ENTRY

WEST 1/4 CORNER SECTION 21 TOWNSHIP 5 SOUTH RANGE 3 EAST FND. 1" IRON PIPE

EAST 1/4 CORNER SECTION 21 TOWNSHIP 5 SOUTH RANGE 3 EAST FND. BRASS CAP FLUSH

SOUTH 1/4 CORNER SECTION 21 TOWNSHIP 5 SOUTH RANGE 3 EAST CALCULATED POSITION NOTHING FND. OR SET

SOUTHEAST CORNER SECTION 21 TOWNSHIP 5 SOUTH RANGE 3 EAST FND. BRASS CAP FLUSH

REGISTERED LAND SURVEYOR
 CERTIFICATE NO. 33851
 RICHARD G. ALCOCKER
 10-18-21
 ARIZONA U.S.A.

Richard G. Alcocker

03 SHEET OF 03

CIVL Contact: JERRY DODD
 CIVL Project #: 1-01-03723-01

© 2021 Coe & Van Loo Consultants, Inc. All rights reserved. No reproduction in any format.





VENIDA
 OPEN SPACE & REC. PLAN

Existing Conditions
 Alta Survey
 Exhibit D.3

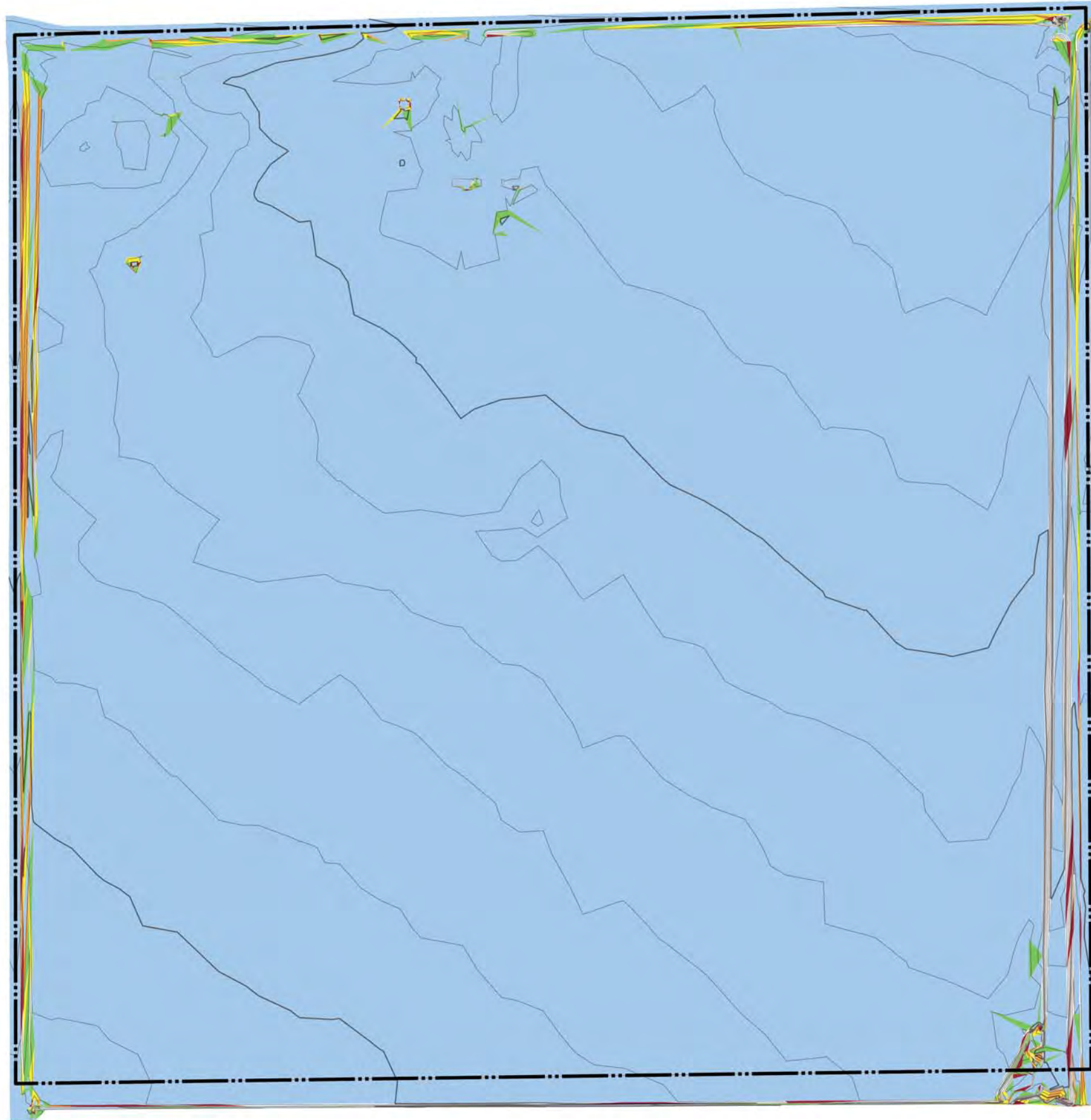
Site and Slope Analysis Plan

Exhibit E



SLOPE TABLE		
	Minimum Slope	Maximum Slope
	0%	5%
	5%	10%
	10%	15%
	15%	20%
	20%	25%

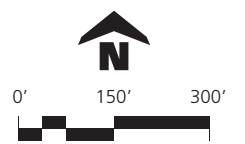

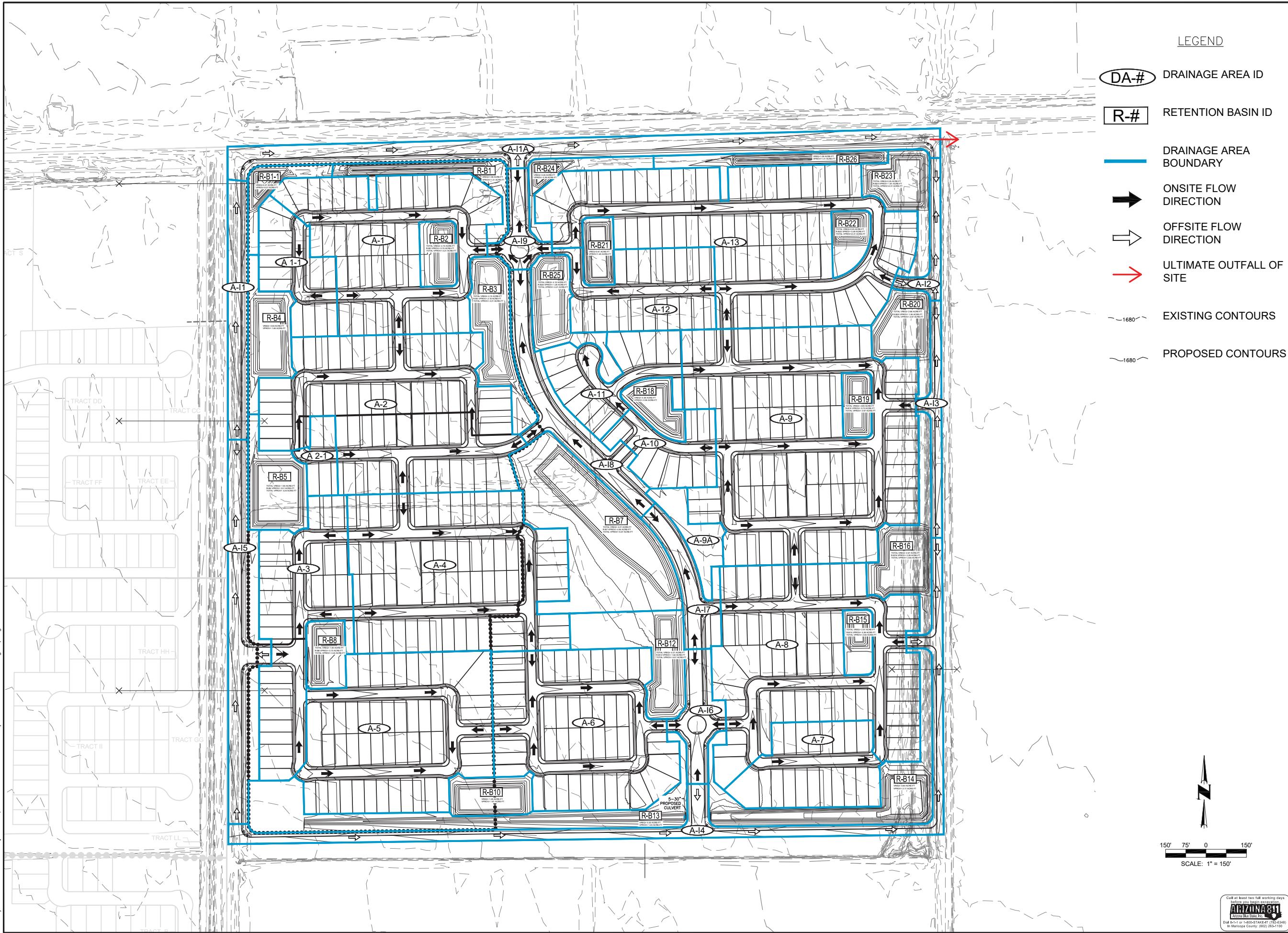

- LEGEND**
- DA-# DRAINAGE AREA ID
 - R-# RETENTION BASIN ID
 - DRAINAGE AREA BOUNDARY
 - ➔ ONSITE FLOW DIRECTION
 - ➔ OFFSITE FLOW DIRECTION
 - ➔ ULTIMATE OUTFALL OF SITE
 - EXISTING CONTOURS
 - PROPOSED CONTOURS



NO.	REVISION	DATE

DRAINAGE MAP

VENIDA
PINAL COUNTY, ARIZONA

PLATE 1

1 SHEET OF 1

CVL Contact: NICHOLAS STAFFORD
CVL Project #: 01-03723-01
CVL File #:

Coe & Van Loo Consultants, Inc.



**Preliminary Hydrology Analysis
Drainage Map**
Exhibit F



Plant #	Common Name	Caliper (in)	Width (ft)	Height (ft)	Status	Comments
1	Mesquite	14	20	18	S	
2	Blue Palo Verde	10	15	14	S	
3	Mesquite	18	22	16	NS	Trunk Damage / Cambium Damage
4	Mesquite	54	80	32	NS	Wide Base / Trunk Damage
Summary						Legend
		Trees	Cacti	Total		S = Salvageable
Salvageable		2	0	2		NS = Non Salvageable
Non-Salvageable		2	0	2		D = Destroy
Remain In Place		0	0	0		RIP = Remain In Place
Total Plants		4	0	4		

- Plant Legend**
- Tree - Salvageable
 - Tree - Non-Salvageable
 - Tree - Remain In Place
 - Cacti - Salvageable
 - Cacti - Non-Salvageable
 - Cacti - Remain In Place

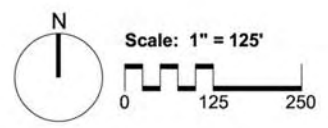



Native Resources
INTERNATIONAL

Native Resources Intl.
1540 W Happy Valley Rd.
Phoenix, AZ. 85085
Phone (623) 869-6757
Fax (623) 869-6769

Venida
SEC of Papago Road & Green Road
Pinal County, Arizona

Native Plant Inventory Plan

DATE: 9/16/2021

REVISION:

SCALE: 1" = 125'

CHECKED:

DRAWN: KB

SHEET **1** OF 1

LEGEND	
S	Salvageable
NS	Non Salvageable
D	Destroy
RIP	Remain in Place

SUMMARY			
	TREES	CACTI	TOTAL
Salvageable	2	0	2
Non-Salvageable	2	0	2
Remain In Place	0	0	0
Total Plants	4	0	4

INVENTORY						
PLANT #	COMMON NAME	CALIPER (IN)	WIDTH (FT)	HEIGHT (FT)	STATUS	COMMENTS
1	Mesquite	14	20	18	S	
2	Blue Palo Verde	10	15	14	S	
3	Mesquite	18	22	16	NS	Trunk Damage / Cambium Damage
4	Mesquite	54	80	32	NS	Wide Base / Trunk Damage

Proposed Site Plan

Exhibit I



LEGEND

- 55' x 120'
- 45' x 120'
- Open Space
- Trails

SITE DATA		
Gross Area	158.25 acres	
Zoning	R-7/PAD	
Max. Density Permitted	3.50 du/ac	
Approximate Density Provided	± 3.44 du/ac	
Approximate Number of Lots	45' x 120'	± 388 lots
	55' x 120'	± 156 lots
	Total	± 544 lots
Open Space Required	± 28.48 acres	± 18%

SITE COMPARISON				
Site Data	Existing Plan		Proposed Plan	
Gross Area	158.50 acres		158.25 acres	
Commercial Area	15.00 acres		0.00 acres	
Residential Area	143.50 acres		158.25 acres	
Zoning	CR-3/PAD & CB-1/PAD		R-7/PAD	
Max. Density Permitted	3.50 du/ac		3.50 du/ac	
Approximate Density Provided	3.50 du/ac		± 3.44 du/ac	
Open Space Required	21.53 acres	15%	± 28.48 acres	± 18%
Lot Mix	Existing Plan		Proposed Plan	
45' X 120'			± 388 lots	± 71%
48' X 115'	220 lots	44%		
55' X 120'			± 156 lots	± 29%
58' X 115'	190 lots	38%		
68' X 120'	92 lots	18%		
Total	502 lots	100%	± 544 lots	100%

Note: Final lot counts, density, open space, and individual parcel data are subject to change and will be finalized during the Tentative Plat and Final Plat processes.



Open Space and Amenities Plan

Exhibit J

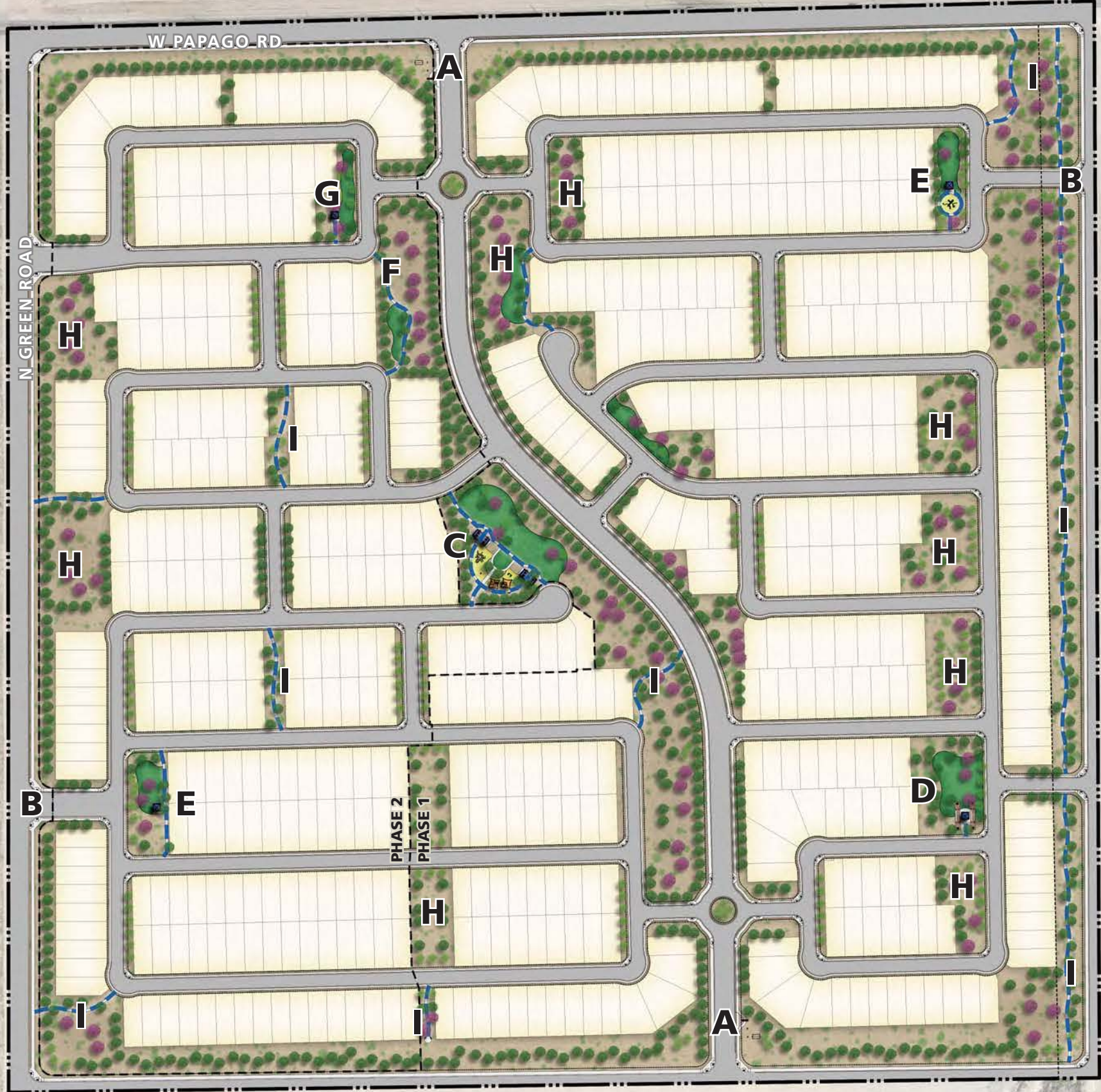

LEGEND

- A** Primary Entry Monument
- B** Secondary Entry Signage
- C** Main Park
 - Play Structure
 - Two Large Ramada / Picnic Areas
 - Multi-Use Fields
 - Lighting at Amenities
- D** Small Community Park
 - Corn Hole
 - Ramada / Picnic Area
- E** Small Community Park
 - Play Structure
 - Ramada / Picnic Area
- F** Garden Walk
 - Pollinator Garden
 - Hardscape and Benches
- G** Picnic Area
 - Pickleball
 - Ramada / Picnic Area
- H** Planted Open Space
- I** Planted Open Space with Pathway







Wall & Signage Plan

Exhibit K



LEGEND

-  Primary Entry Monument
-  Secondary Entry Signage
-  Theme Wall at Entry
-  Theme Wall
-  Secondary Wall

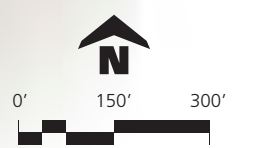

Major Entry Plan
Exhibit L

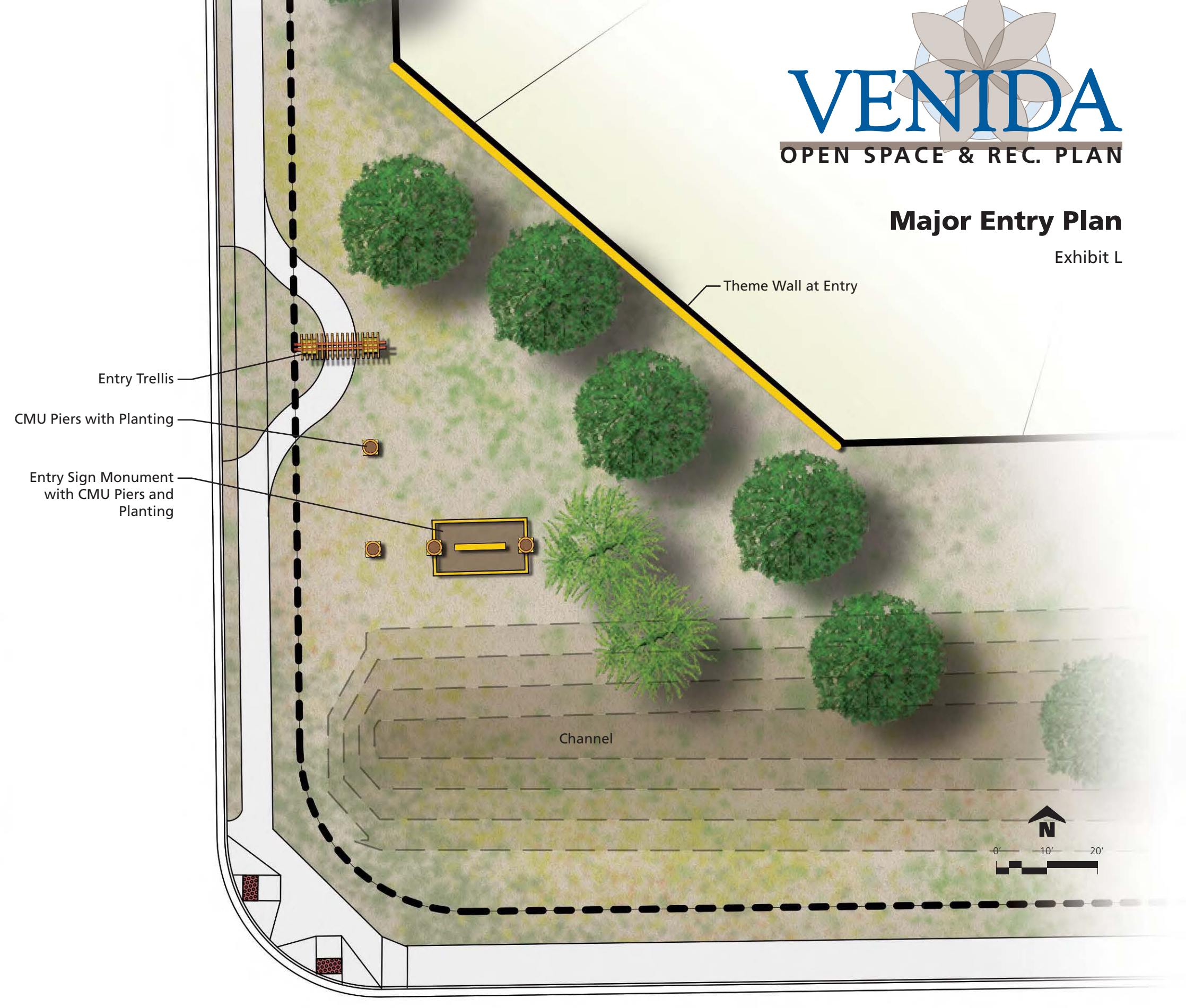
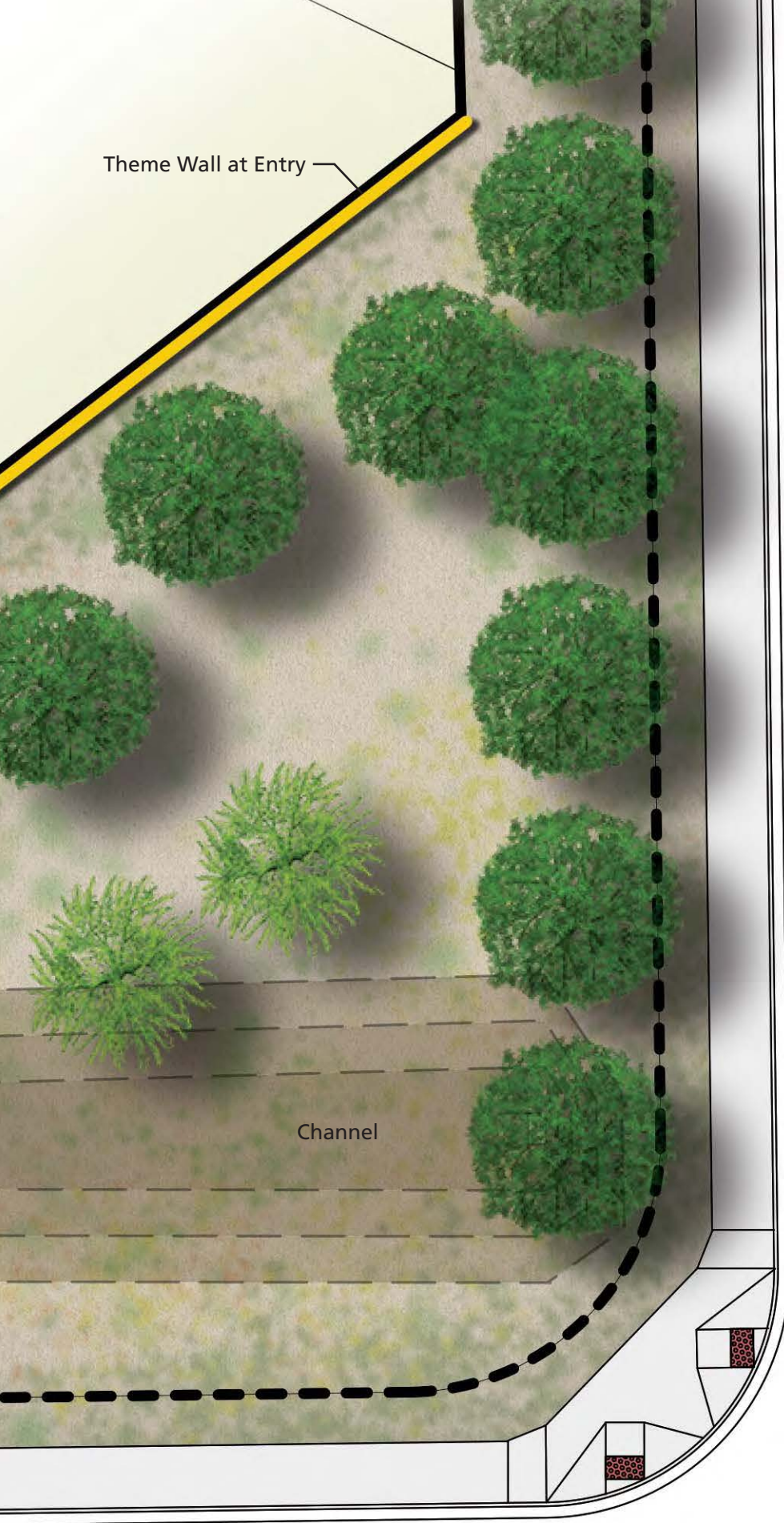

**Main Park
Conceptual
Landscape Plan**

Exhibit M

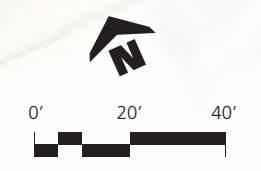

Primary Entry Elevation

Exhibit N



PRIMARY ENTRY MONUMENT ELEVATION

- Decorative Planter Set On CMU Plinth With Integral Irrigation
- Row Lock CMU Column Cap
- Splitface CMU
- Freestanding Stone Veneer Wall With Pin Mount Lettering
- Raised Planter At Grade Smooth CMU



ENTRY ACCENT WALL ELEVATION

**Secondary Entry and
Wall Elevations**

Exhibit O

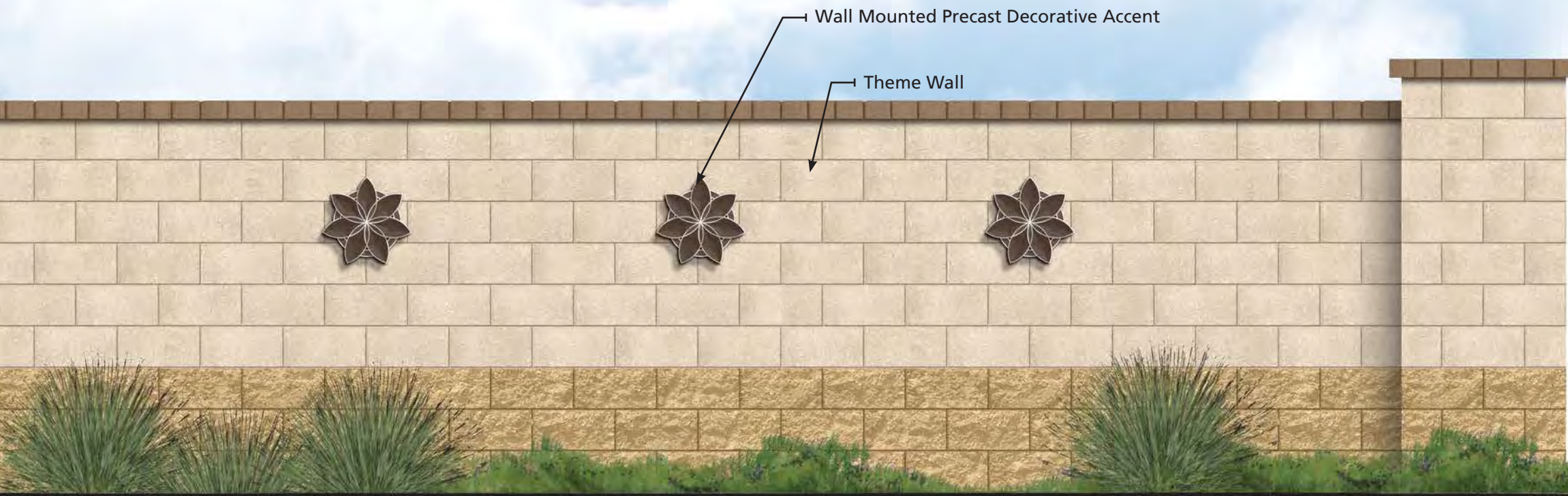

SECONDARY ENTRY ACCENTS



SECONDARY WALL

THEME WALL

Landscape Master Plan

Exhibit P

PLANT LEGEND

Trees	
<i>Acacia farnesiana</i>	Sweet Acacia
<i>Acacia salicina</i>	Willow Acacia
<i>Caesalpinia cacalaco</i> 'Smoothie' TM	Smoothie Thornless Cascalote
<i>Chilopsis linearis</i>	Desert Willow
<i>Dalbergia sissoo</i>	Rosewood
<i>Fraxinus velutina</i> 'Fan Tex'	Fan-Tex Ash
<i>Olea europaea</i> 'Swan Hill' TM	Swan Hill Olive
<i>Parkinsonia x</i> 'Desert Museum'	Desert Museum Palo Verde
<i>Pistacia x</i> 'Red Push'	Pistache
<i>Prosopis chilensis</i>	Chilean Mesquite
<i>Quercus virginiana</i>	Southern Live Oak
<i>Sophora secundiflora</i>	Texas Mountain Laurel
<i>Tipuana tipu</i>	Tipu Tree
<i>Ulmus parvifolia</i> 'True Green'	True Green Elm
Shrubs And Accents	
<i>Agave geminiflora</i>	Twin Flowered Agave
<i>Asclepias subulata</i>	Rush Milkweed
<i>Bougainvillea x</i> 'Barbara Karst'	Barbara Karst Bougainvillea
<i>Bougainvillea x</i> 'Torch Glow'	Torch Glow Bougainvillea
<i>Caesalpinia pulcherrima</i>	Red Bird Of Paradise
<i>Calliandra californica</i>	Red Baja Fairy Duster
<i>Cordia boissieri</i>	Anacahuita
<i>Dalea frutescens</i>	Black Dalea
<i>Dasyliirion acrotriche</i>	Toothless Sotol
<i>Dasyliirion longissimum</i>	Toothless Desert Spoon
<i>Hesperaloe parviflora</i>	Red Yucca
<i>Hesperaloe Parviflora</i> 'Perpa' TM	Brakelights Red Yucca
<i>Leucophyllum Candidum</i> 'Silver Cloud' TM	Silver Cloud Texas Sage
<i>Leucophyllum laevigatum</i>	Chihuahuan Sage
<i>Muhlenbergia rigens</i>	Deer Grass
<i>Pedilanthus macrocarpus</i>	Slipper
<i>Senna artemisioides</i>	Silver Senna
<i>Tecoma stans</i>	Yellow Bells
<i>Tecoma x</i> 'Sparky'	Sparky Yellow Bells
Groundcovers	
<i>Carissa Macrocarpa</i> 'Green Carpet'	Green Carpet Natal Plum
<i>Eremophila Glabra</i> 'Mingenew Gold'	Outback Sunrise Emu Bush
<i>Lantana montevidensis</i>	Trailing Lantana
<i>Lantana x</i> 'New Gold'	New Gold Lantana
<i>Myoporum parvifolium</i>	Trailing Myoporum
<i>Rosmarinus officinalis</i> 'Prostratus'	Dwarf Rosemary



Landscape Tract Plan Phase 1 Exhibit Q.1

LEGEND

- Open Space
- Landscape Tract



PHASE 1 OPEN SPACE

TRACT	AREA	DESCRIPTION
TRACT A	4.05 AC	Open Space/ Landscape Tract/ Retention
TRACT B	0.43 AC	Pocket Park/ Open Space/ Landscape Tract/ Retention
TRACT C	0.46 AC	Open Space/ Landscape Tract/ Retention
TRACT D	1.76 AC	Open Space/ Landscape Tract/ Retention
TRACT G	4.02 AC	Open Space/ Landscape Tract/ Retention/ Trail
TRACT H	0.78 AC	Pocket Park/ Open Space/ Landscape Tract/ Retention
TRACT I	0.51 AC	Open Space/ Landscape Tract/ Retention
TRACT J	0.76 AC	Open Space/ Landscape Tract/ Retention
TRACT M	0.90 AC	Open Space/ Landscape Tract/ Retention
TRACT N	0.76 AC	Open Space/ Landscape Tract/ Retention
TRACT O	0.92 AC	Pocket Park/ Open Space/ Landscape Tract/ Retention
TRACT P	0.27 AC	Open Space/ Landscape Tract/ Retention
TRACT R	0.53 AC	Open Space/ Landscape Tract/ Retention
TRACT S	3.40 AC	Open Space/ Landscape Tract/ Retention/ Trail
TRACT T	1.72 AC	Open Space/ Landscape Tract/ Retention
TRACT V	0.58 AC	Open Space/ Landscape Tract/ Retention
TRACT W	0.57 AC	Open Space/ Landscape Tract/ Retention
TRACT Y	4.70 AC	Neighborhood Park/ Open Space/ Landscape Tract/ Retention
Sub-Total	27.11 AC	

PHASE 1 LANDSCAPE TRACT

TRACT	AREA	DESCRIPTION	TRACT	AREA	DESCRIPTION
TRACT E	0.08 AC	Landscape Tract	TRACT U	0.08 AC	Landscape Tract
TRACT F	0.08 AC	Landscape Tract	TRACT X	0.08 AC	Landscape Tract
TRACT K	0.04 AC	Landscape Tract	TRACT SS	0.06 AC	Landscape Median
TRACT L	0.08 AC	Landscape Tract	TRACT TT	0.06 AC	Landscape Median
TRACT Q	0.08 AC	Landscape Tract	Sub-Total	0.65 AC	

PHASE 1

Open Space	27.11 AC
Landscape Tract	0.65 AC
Total	27.77 AC

PHASE 2

Open Space	11.42 AC
Landscape Tract	0.90 AC
Total	12.32 AC
Grand Total	40.08 AC

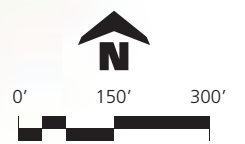

15 April 2022

Landscape Tract Plan Phase 2 Exhibit Q.2



LEGEND

- Open Space
- Landscape Tract

PHASE 2 OPEN SPACE

TRACT	AREA	DESCRIPTION
TRACT Z	2.52 AC	Open Space/ Landscape Tract/ Retention
TRACT BB	0.57 AC	Pocket Park/ Open Space/ Landscape Tract/ Retention/ Trail/ Amenities
TRACT DD	0.28 AC	Open Space/ Landscape Tract/ Retention/ Trail
TRACT II	2.95 AC	Open Space/ Landscape Tract/ Retention
TRACT KK	0.34 AC	Open Space/ Landscape Tract/ Retention
TRACT MM	1.93 AC	Pocket Park/ Open Space/ Landscape Tract/ Retention/ Trail/ Amenities
TRACT QQ	0.40 AC	Pocket Park/ Open Space/ Landscape Tract/ Retention
TRACT RR	2.43 AC	Open Space/ Landscape Tract/ Retention
Sub-Total	11.42 AC	

PHASE 2 LANDSCAPE TRACT

TRACT	AREA	DESCRIPTION	TRACT	AREA	DESCRIPTION
TRACT AA	0.07 AC	Landscape Tract	TRACT JJ	0.07 AC	Landscape Tract
TRACT CC	0.09 AC	Landscape Tract	TRACT LL	0.08 AC	Landscape Tract
TRACT EE	0.08 AC	Landscape Tract	TRACT NN	0.08 AC	Landscape Tract
TRACT FF	0.08 AC	Landscape Tract	TRACT OO	0.08 AC	Landscape Tract
TRACT GG	0.08 AC	Landscape Tract	TRACT PP	0.09 AC	Landscape Tract
TRACT HH	0.08 AC	Landscape Tract	Sub-Total	0.90 AC	

PHASE 1		PHASE 2	
Open Space	27.11 AC	Open Space	11.42 AC
Landscape Tract	0.65 AC	Landscape Tract	0.90 AC
Total	27.77 AC	Total	12.32 AC
		Grand Total	40.08 AC

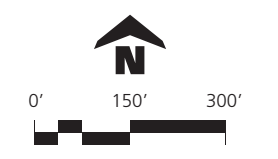



Julie Vermillion
 Coe & Van Loo Consultants, Inc.
 4550 N 12th Street
 Phoenix, Arizona 85014

September 10, 2021

RE: Venida
 Parcels 510520030 and 510520020

Dear Julie,

The Arizona State Museum (ASM) has reviewed archaeological project and site records in support of the following project:

Coe & Van Loo Consultants, Inc.’s Venida project (Project No. 1-01-0372301; ASM Job No. 003922)

Correspondence indicates this project will involve the proposed PAD development of privately-owned land at the SEC of Papago Road and Green Road, near the town of Stanfield, Pinal County. The project area encompasses parcels 510520030 and 510520020 within Township 5 South, Range 3 East, Section 21.

I invite you to review the results of ASM’s research, which are summarized below.

Search Results:

According to a search of the archaeological site records and reports held in ASM collections, eight archaeological investigations were conducted within a one-mile radius of the project area between 1982 and 2009. One of these archaeological investigations intersects the project area; Table 1 summarizes its basic information and scope.

ASM Reference Number (AZProj/Accession)	Report Author(s)	Year(s) Conducted	Scope of Project
AP-2009-0189	Walker et al.	2009	Survey for vegetation maintenance and general inventory of cultural resources along transmission lines

Table 1. ASM archaeological investigations that intersect the project area

No archaeological sites have been identified within a one-mile radius of the project area.

Recommendations and Responsibilities:

1. Since a portion of the project area has not been subject to prior archaeological survey, ASM recommends—but does not require—that a qualified archaeological contractor be consulted before any ground-disturbing activity begins.

Additionally, in the portions of the project area that have been previously surveyed, the work was conducted 12 years ago. It is standard archaeological practice for a property to be re-surveyed if the previous survey was conducted 10 or more years ago, as there is a possibility for previously unidentified archaeological sites to have since been exposed. For this reason, ASM recommends—but does not require—that a qualified archaeological contractor be consulted before any ground-disturbing activity begins.

A list of archaeological contractors is available on the ASM website at:
<https://statemuseum.arizona.edu/crm/document/aaa-qualified-consultants>

2. Pursuant to Arizona Revised Statute §41-865, if any human remains or funerary objects are discovered during project work, all work must stop within the area of the remains and the ASM Repatriation Office must be contacted at 520-626-0320.

3. City, county, or municipal governments may have their own requirements; therefore, ASM recommends that the relevant jurisdiction(s) be consulted.

If you have any questions about the results of this records search, please feel free to contact me at efioccop@arizona.edu or 520-621-4011.

Kind regards,



Emily Fiocoprile, PhD

Assistant Manager
Archaeological Records Office
Arizona State Museum
520-621-4011
efioccop@arizona.edu

References:

Walker J, Stehman K, and Fahrni G (2010) *A cultural resources survey for the federal- and state-land portions of the Arizona Public Service Company 80.41-mile-long (487.33-acre) SE-1 (Maricopa–Casa Grande) and 7.31-mile-long (44.30-acre) SE-2 (Maricopa–Papago) 69-kV transmission lines in Pinal County, Arizona.* LSD Technical Report No. 075107 (SE-1 & SE-2a). Tempe, AZ: Logan Simpson Design Inc.

Phasing Plan
Exhibit S

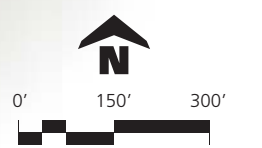
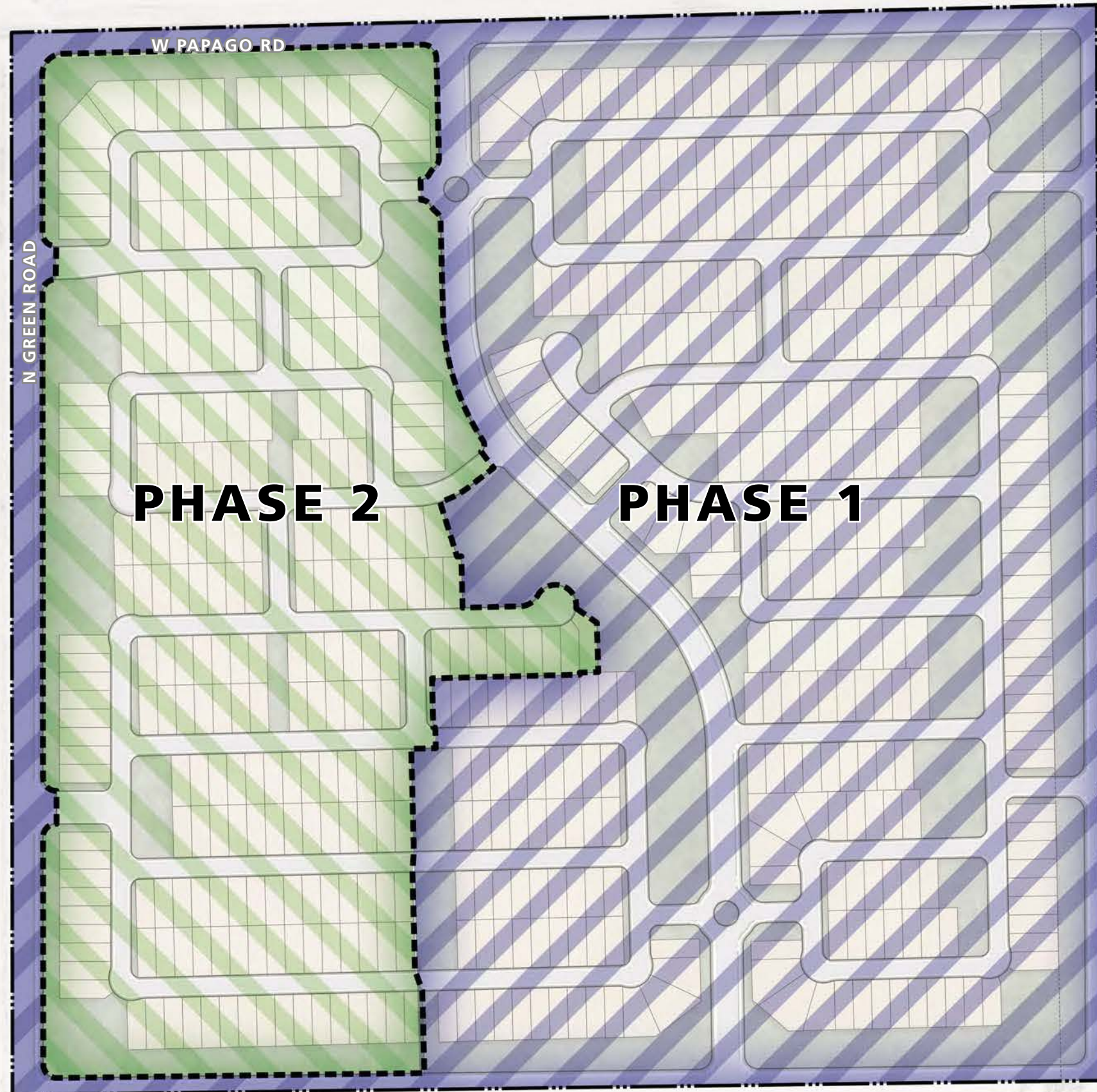





Lighting Plan

Exhibit T



LEGEND

	Perimeter Roads
	• No Lighting Along Roadway (Except Street Lights If Provided)
	Residential Light Zone
	• Low Intensity Shielded Lights
	Entry Zone
	• Monument Lights
	• Accent Lighting At Theme Features
	• Bollard Lighting Along Entry
	Open Space Zone
	• Bollards Along Path When Outside Of Retention
	• Accent Lighting

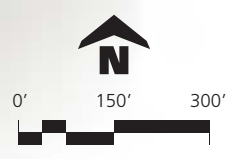



Venida

LGI Homes
APN 510-52-0020 & 510-25-0030
Pinal County

Summary of Neighborhood Meeting September 9, 2021



Neighborhood Meeting Summary

The neighborhood meeting for the Rezone and Planned Area Development (PAD) Amendment of APN Nos. 510-52-0020 and 510-25-0030 from Single Residence Zone (CR-3/PAD) and General Commercial (CB-1/PAD) Zoning Districts to \ Single Residence Zone (CR-3/PAD) for a 554-unit single-family residential development was held at Copper Sky Recreation Complex at 6:00pm on September 9, 2021.

Members of the Development Team in attendance:

Rick Tayrien – LGI Homes

Eric Berman - LGI Homes

Julie Vermillion – CVL Consultants

Veanette Hanson – CVL Consultants

Carolyn Oberholtzer – Bergin, Frakes, Smalley & Oberholtzer (“BFSO”)

Nicholas Gonzales – BFSO

The in person meeting at Copper Sky Rec. Complex opened to the public at 5:50pm with the members of the development team present and available to share information related to the companion applications and answer any questions.

No members of the public attended the neighborhood meeting.

The meeting was adjourned at 7:00pm.

September 24, 2021

LEGAL DESCRIPTION FOR
VENIDA
PROPERTY BOUNDARY

That part of the Northwest Quarter of Section 21, Township 5 South, Range 3 East, of the Gila and Salt River Meridian, Pinal County, Arizona, more particularly described as follows:

Beginning at the Northwest Corner of said Section 21;

Thence North $88^{\circ}32'15''$ East, along the North line of the Northwest Quarter of said Section 21, a distance of 2,643.85 feet, to the North Quarter Corner of said Section 21;

Thence departing said North line, South $00^{\circ}17'18''$ East, along the East line of said Northwest Quarter, a distance of 2,618.77 feet, to the Center of said Section 21;

Thence South $89^{\circ}14'14''$ West, along the South line of said Northwest Quarter, a distance of 2,653.95 feet, to the West Quarter Corner of said Section 21;

Thence North $00^{\circ}03'15''$ West, along the West line of said Northwest Quarter, a distance of 2,586.59 feet to the Point of Beginning.

Containing 6,893,158 Square Feet or 158.245 Acres, more or less.

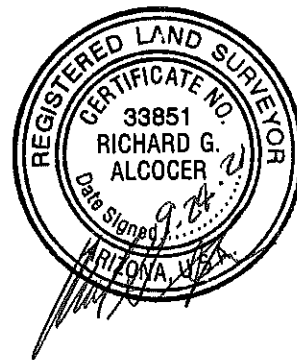

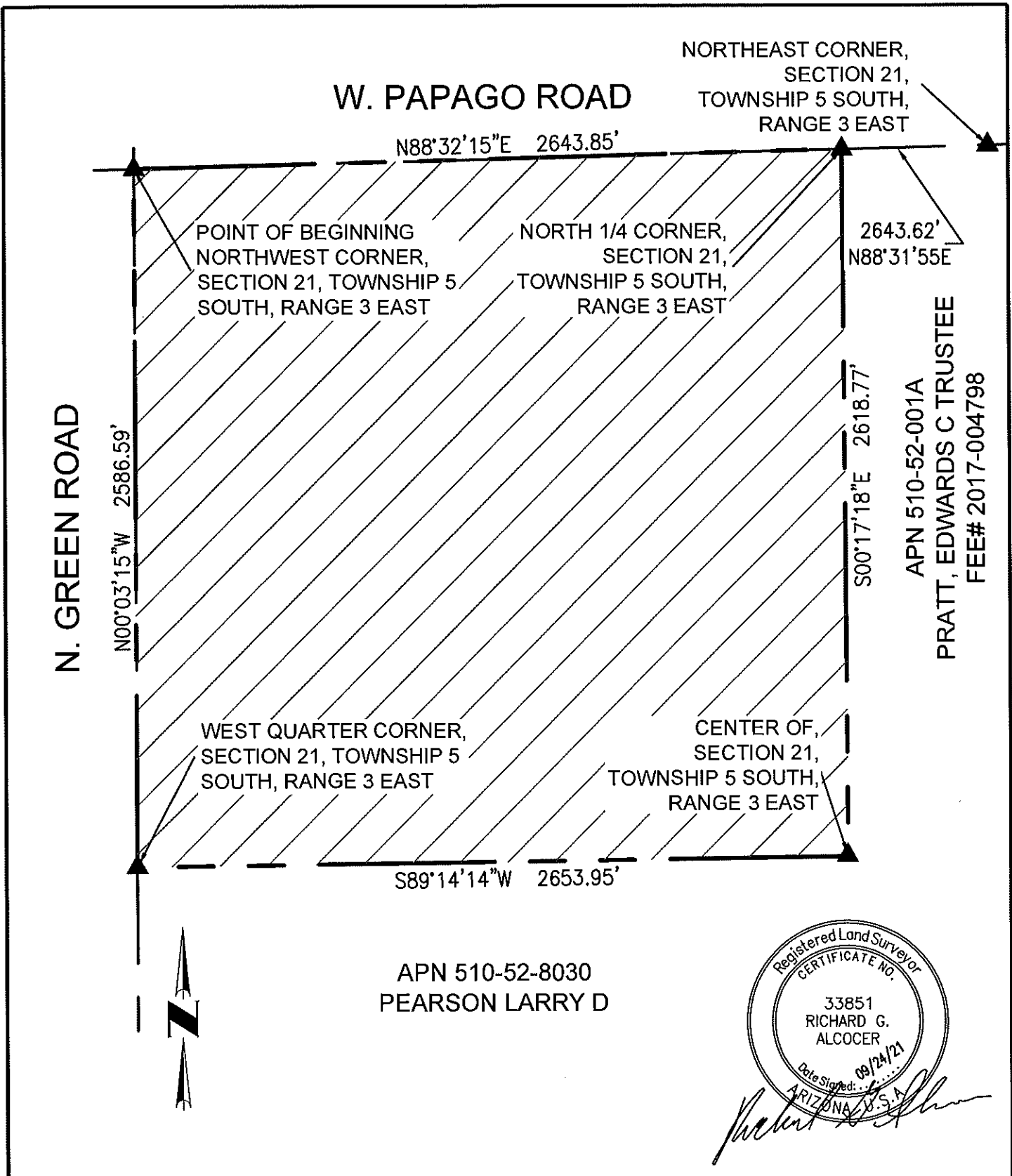

APN 510-52-8030
PEARSON LARRY D

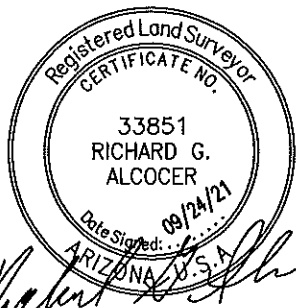

APN 510-52-001A
PRATT, EDWARDS C TRUSTEE
FEE# 2017-004798

SCALE 1" = 500'
EXHIBIT
4550 North 12th Street
Phoenix, Arizona 85014
Phone 602-264-6831
<http://www.cvlc.com>

VENIDA
PROPERTY BOUNDARY

1 OF 1

CLOSURE REPORT
VENIDA
PROPERTY BOUNDARY

BOUNDARY

N88°32'14.6248" E 2,643.85

S00°17'17.7300" E 2,618.77

S89°14'14.1005" W 2,653.95

N00°03'15.1368" W 2,586.59

Area = 6,893,158 158.245 AC

Closing course: 276°40'43.3655" 0.007208

Misclosure: 1/1,000,000+

North Error: 0.000838

East Error: 0.007159

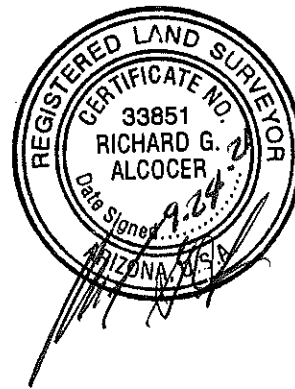

NO.	REVISION	DATE
1	ADDED ITEM 7 & 11. UPDATED PARCELS ON MAPPING SHEET	09/08/21
2	ADDED PROPOSED PHASING LINES ON MAPPING SHEETS	09/20/21
3	VERIFIED SITE CONDITIONS	10/14/21

Coe & Van Loo Consultants, Inc.

A.L.T.A. / N.S.P.S. LAND TITLE SURVEY

VENIDA
MARIKOPA, ARIZONA

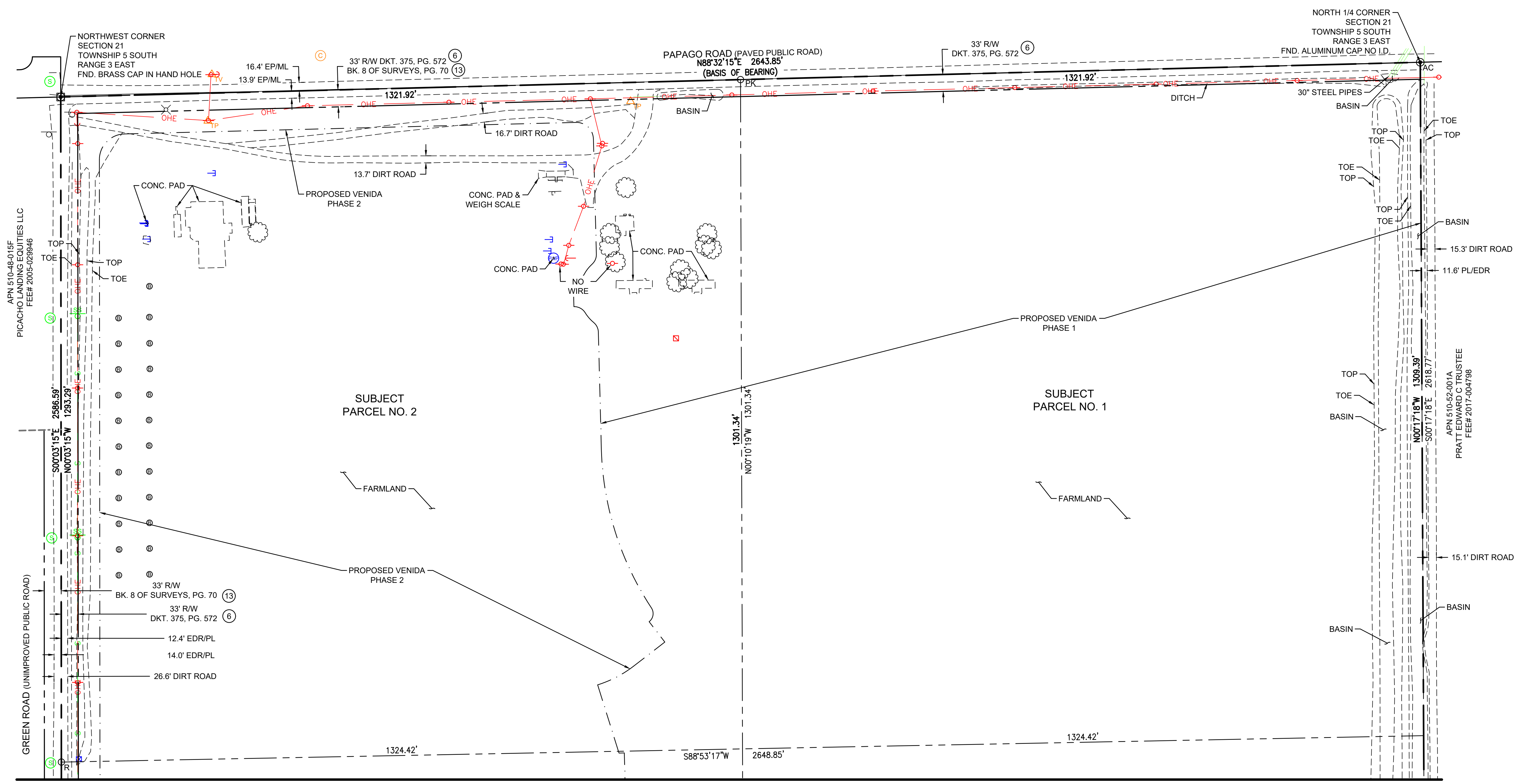
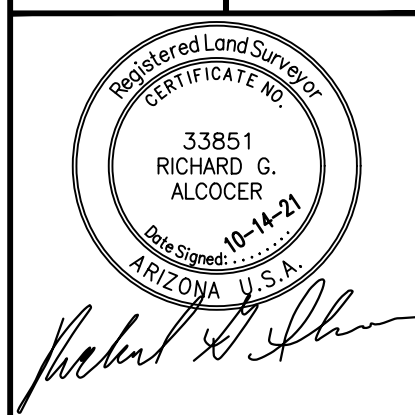

MATCH SHEET 3

MATCH SHEET 3

LEGEND

APN	ASSESSOR PARCEL NUMBER	TOP	TOP OF SLOPE		POWER POLE		TELEPHONE PEDESTAL
CONC.	CONCRETE	TOE	TOE OF SLOPE		POLE STREET LIGHT		CABLE TV PEDESTAL
CLD	CONCRETE LINED DITCH		CALCULATED POSITION - NOTHING FOUND, NOTHING SET		ELECTRIC METER		BOLLARD
CMU	CONCRETE MASONRY UNIT		FOUND BRASS CAP FLUSH		WATER METER		PROPERTY LINE
ESMT	EASEMENT		FOUND BRASS CAP IN HAND HOLE		WELL PUMP		UNDERGROUND SEWER LINE
EP	EDGE OF PAVEMENT		FOUND ALUMINUM CAP		STUB OUT		OVERHEAD ELECTRIC LINE
EDR	EDGE OF DIRT ROAD		FOUND REBAR		SIGN		CMU WALL
FND.	FOUND		FOUND IRON PIPE		TREE (GENERIC)		PROPOSED PHASING LINE
ML	MONUMENT LINE		SET PK-NAIL WITH WASHER LS#33851		MANHOLE SANITARY SEWER		SCHEDULE B ITEM NUMBER
PL	PROPERTY LINE		SET 1/2" REBAR WITH CAP LS#33851		SIGN - SEWER UNDERGROUND		
R/W	RIGHT-OF-WAY		DOWNGUY		MANHOLE COMMUNICATIONS		

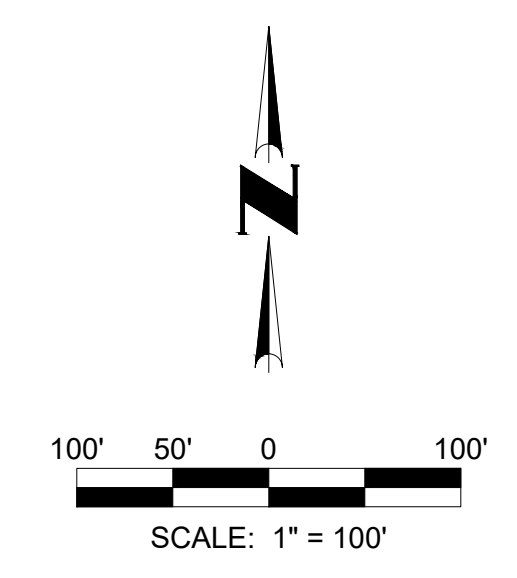

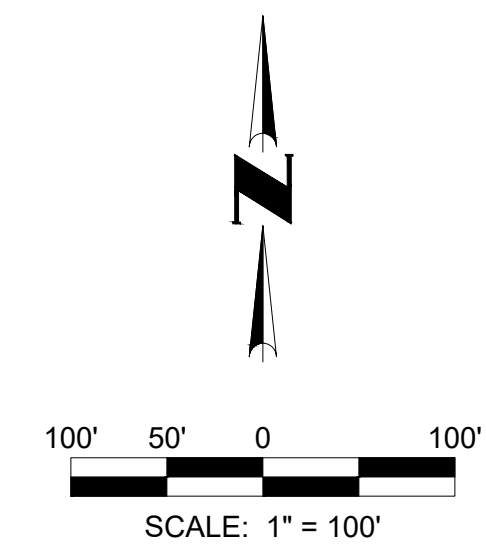

MATCH SHEET 2

MATCH SHEET 2

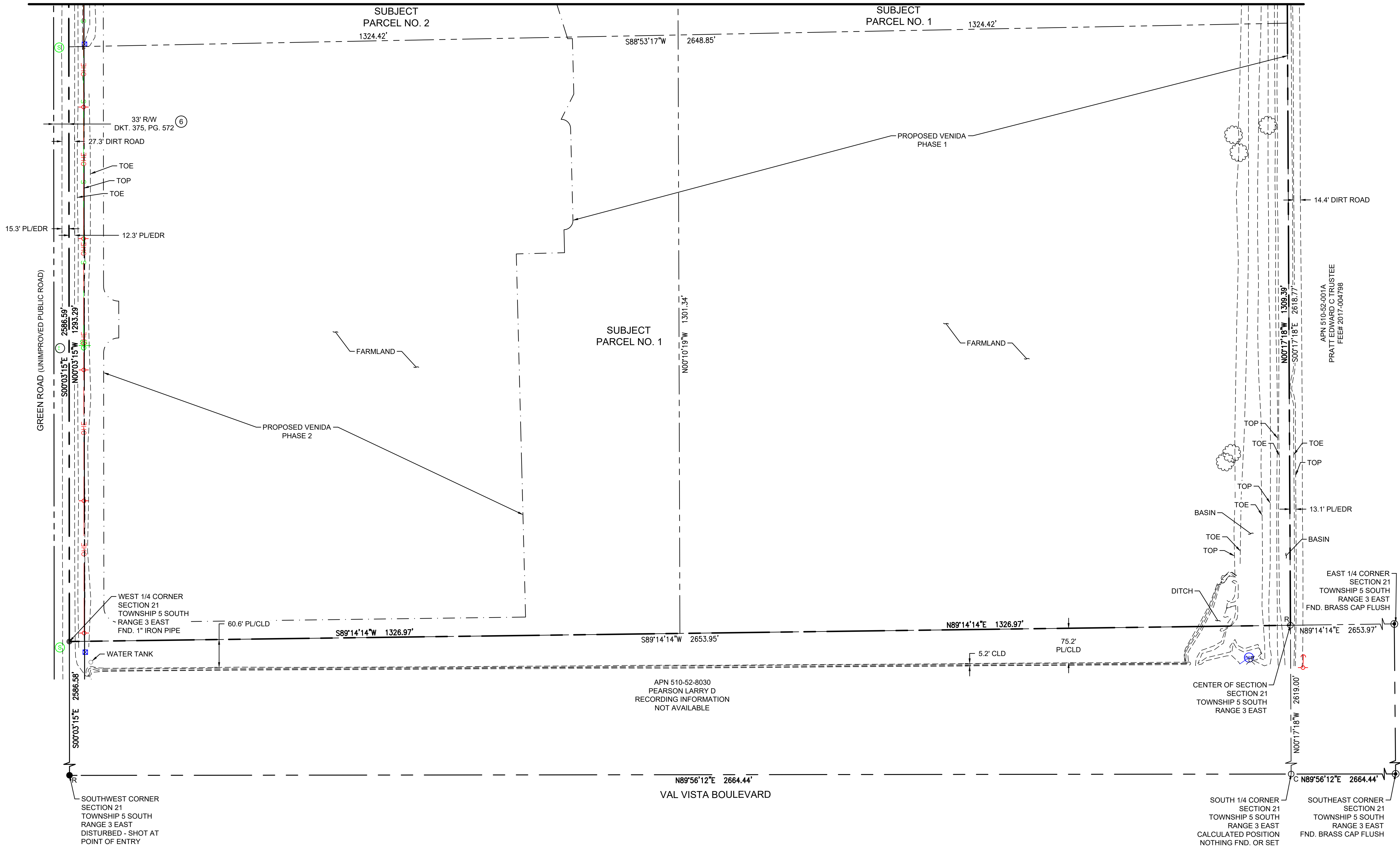

NO.	REVISION	DATE
1	ADDED ITEM 7 & 11. UPDATED PARCELS ON MAPPING SHEET	09/08/21
2	ADDED PROPOSED PHASING LINES ON MAPPING SHEETS	09/20/21
3	VERIFIED SITE CONDITIONS	10/14/21

Coe & Van Loo Consultants, Inc.

A.L.T.A. / N.S.P.S. LAND TITLE SURVEY

VENIDA
MARICOPA, ARIZONA

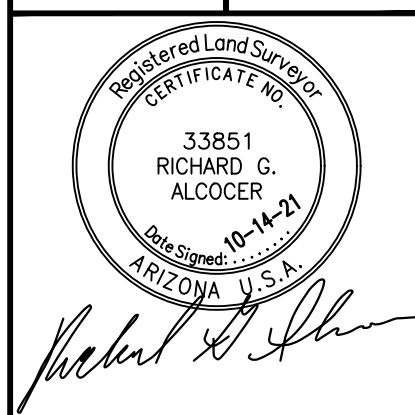

Printed By: Braith Print Date: October 14, 2021 Filename: N:\010372301\CADD\ALTANS\ALTA.dwg

Master Drainage Report

September 30, 2021

VENIDA PHASES 1 & 2

Pinal County, Arizona

Master Drainage Report

Prepared for:

LGI HOMES

9105 E. Del Camino Drive
Suite 118
Scottsdale, Arizona 85258
Contact: Rick Tayrien

Prepared by:

Coe & Van Loo Consultants, Inc.

4550 N 12th Street
Phoenix, AZ 85014
Contact: Nicholas Stafford, PE, CFM
(602) 264-6831

Job #1-01-0372301

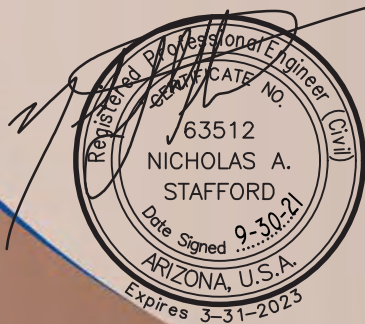

Master Drainage Report
For
Venida
Pinal County, Arizona

September 30, 2021

Prepared for:

LGI Homes

9105 E. Del Camino Drive

Suite 118

Scottsdale, Arizona 85258

Contact: Rick Tayrien

Prepared by:

Coe & Van Loo Consultants, Inc.

4550 N. 12th Street

Phoenix, AZ 85014

(602) 264-6831

CVL Job Number: 1-01-0372301

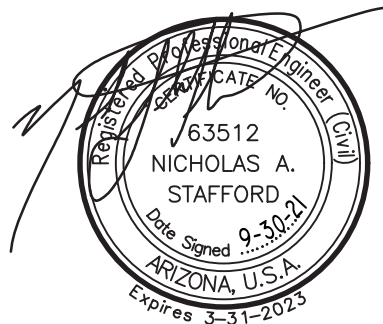

Master Drainage Report For Venida

Table of Contents

1.0 INTRODUCTION	4
1.1 Scope	4
1.2 Site Description and Existing Conditions	4
1.3 Proposed Development	5
1.4 Regulatory Jurisdiction.....	5
2.0 FLOOD ZONE INFORMATION	5
3.0 MANAGEMENT OF OFF-SITE RUNOFF	6
3.1 Off-Site Hydrology.....	6
3.2 Off-site Runoff Management Plan	6
4.0 MANAGEMENT OF ON-SITE RUNOFF	7
4.1 On-Site Hydrology	7
4.2 On-Site Runoff Management Plan	7
4.3 Retention	8
5.0 SUMMARY AND CONCLUSIONS	9
6.0 REFERENCES	10

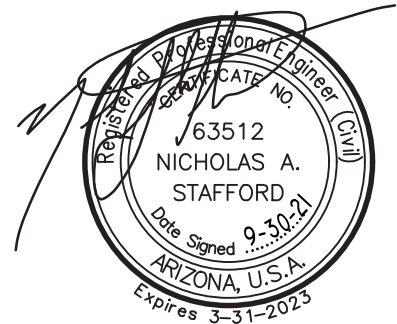

Figures

- Figure 1 Vicinity & Location Map
- Figure 2 Phase Map
- Figure 3 Flood Insurance Rate Map

Exhibits

- Exhibit 1 Pre-Project HEC-1 Schematic Map
- Exhibit 2 Pre-Project HEC-1 Basin Map
- Exhibit 3 Pre-Project Land Use Map
- Exhibit 4 Soils Map

Appendices

- Appendix A Off-Site Hydrology: HEC-1 Model and Exhibits
- Appendix B Off-Site Hydraulics: Channel Calculations
- Appendix C On-Site Hydrology: Rainfall Data, Retention, and Culvert Crossing Calculations

Plate

- Plate 1 On-Site Drainage Map

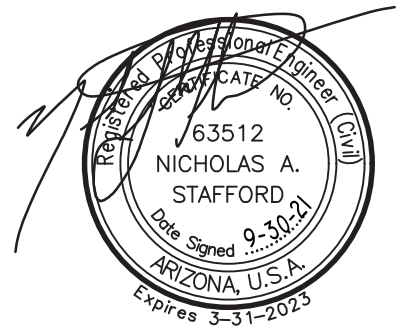

1.0 INTRODUCTION

1.1 Scope

Coe & Van Loo Consultants, Inc. (CVL) has been contracted by LGI Homes (client) to provide engineering services in support of the proposed Venida development (the site). The purpose of this report is to provide preliminary hydrologic analysis for the proposed development. In addition, this report addresses off-site drainage, on-site drainage and retention requirements.

This report is focused on providing practical design information, evaluation, and analysis for statistical flood events up to and including the 100-year frequency flood. The scope of this assessment does not include evaluation of storm-water runoff resulting from events exceeding the 100-year storm. Hence, it should be noted that a storm event exceeding the 100-year frequency may cause or create the risk of greater flood impact than is addressed and presented in this assessment.

The procedures used herein are derived from, and performed with, currently accepted engineering methodologies and practices. Additionally, the criteria for this evaluation conform to currently applicable ordinances, regulations, and policies of Pinal County for the referenced site.

1.2 Site Description and Existing Conditions

The site is located in Pinal County, Arizona, and consists of agricultural fields. The site is located at the northeast corner of W. Papago Rd. and N. Green Rd., within Section 21, Township 5 South, Range 3 East of the Gila and Salt River Base and Meridian, Pinal County, Arizona (see **Figure 1**). The Assessor's Parcel Number is 510-52-0020. The site is rectangular in shape and consists of approximately 160 acres of agricultural fields. The existing agricultural fields slope from the southwest to the northeast at approximately 0.3%. The site is bordered on the north by W. Papago Rd., on the south and east by agricultural fields, and on the west the N. Green Rd. alignment. Similar to other agricultural fields in the vicinity, the site is bordered on the east and west by irrigation and tailwater collection ditches, 1-2 ft berms, and elevated dirt roads, all of which help contain water in the fields for infiltration and agricultural practices. An existing 1-2 ft berm also traverses the southern boundary of the site for similar purposes. A ditch runs along the east side of the site and overflows north into an adjacent depressed area and eventually through an existing culvert. This ditch is assumed to redirect any excess flows generated on the site to the north. A 3-ft pit located at the northeast corner of the site leads to another

existing 3-barrel culvert, likely used in overflow scenarios for the east ditch. Both culverts carry flows north underneath Papago Rd. and discharge to Parcel Number 510-48-804A to the north of Papago Rd.

1.3 Proposed Development

The proposed development consists of single-family residential parcels and infrastructure roads. The site will be constructed in two phases. Phase 1 will include Parcels 1-4. Phase 2 will include Parcels 5-7. Half-street improvements to W. Papago Rd., N. Green Rd, the Southern Infrastructure Rd. and the Eastern Infrastructure Rd. will also be part of the proposed development. See **Figure 2** for a Phase Map.

During final engineering, a final drainage report will be provided for individual parcels. A separate infrastructure final drainage report for each phase will also be provided which will include the design of the adjacent half-streets (W. Papago Rd., and N. Green Rd.) as well as the southern and eastern infrastructure roads.

1.4 Regulatory Jurisdiction

The site will be designed to meet the Pinal County design requirements using the *Pinal County Drainage Manuals (PCDM) Volume I, Design Criteria* [1], *Volume II, Design Methodology and Procedures* [2], and the *Pinal County Drainage Ordinance* [3].

2.0 FLOOD ZONE INFORMATION

The Pinal County, Arizona and Incorporated Areas Flood Insurance Rate Map (FIRM), Map Number 04021C1125E, Map Revised December 4, 2007 [4], indicates the subject site falls within Zone X.

Zone X is defined by FEMA as:

“Areas determined to be outside the 0.2% annual chance floodplain.”

Refer to **Figure 3** for a copy of the Flood Insurance Rate Map (FIRM).

3.0 MANAGEMENT OF OFF-SITE RUNOFF

3.1 Off-Site Hydrology

The off-site runoff that impact the site has been previously studied in the *Vekol Wash Tributary Hydrology Update Report* prepared by Wood, Patel & Associates, Inc. [5] using a HEC-1 analysis. Because this analysis was for a larger study, a more detailed HEC-1 analysis was completed by CVL for the site, using DDMSW Version 5.6.0 [6]. A pre-project HEC-1 model for the 100-yr, 6-hr and 100-yr, 24-hr storm events were completed to determine the flow impacting the site. The 100-yr, 6-hr flows govern with a peak flow of 155-cfs at HEC-1 Station C2. **Appendix A** contains the HEC-1 model outputs, as well as corresponding exhibits, completed by CVL.

Off-site runoff impacts the site from the south. Due to the existing agricultural land use, there is an irrigation ditch, berm, and elevated dirt road along to the west, precluding the off-site flows impacting the west side of the property. The total flow impacting the property from the south is 155-cfs at HEC-1 Station C2.

HEC-1 Peak Flows

HEC-1 Station	100-yr, 6-hr Peak Flow (cfs)	100-yr, 24-hr Peak Flow (cfs)
C1	84	75
C2	155	140

3.2 Off-site Runoff Management Plan

The off-site flow of 155-cfs from the south (HEC-1 Station C2) will be captured through proposed inlets along the southern Collector Road and conveyed into an adjacent channel (South Channel) that runs west to east. Flows will reach basin R-B14 and overtop to the east, restoring the off-site flow pattern back to historic conditions. Since the off-site flows from the south will generally sheet flow onto the Collector Road and into the South Channel, the channel has been sized incrementally in 3 segments. The western third of the South Channel will be a trapezoidal section with 4:1 side slopes, a 2-ft bottom, a

normal depth of 2.0-ft. with an additional 1-ft. of freeboard, and a top width of 26-ft to convey a peak flow of 42-cfs (half of the peak flow at HEC-1 Station C1). The middle third of the South Channel will be a trapezoidal section with 4:1 side slopes, a bottom width of 8-ft, a normal depth of 2-ft with an additional 1-ft. of freeboard, and a top width of 32-ft to convey a peak flow of 84-cfs (HEC-1 Station C1). The eastern third of the South Channel will be a trapezoidal section with 4:1 side slopes, a bottom width of 18-ft, a normal depth of 2-ft with an additional 1-ft of freeboard, and a top width of 42-ft to convey a peak flow of 155-cfs (HEC-1 Station C2). Erosion control will be provided along the channel, as needed, in accordance with [2]. Five (5) 30" pipes will be provided for a proposed culvert crossing at the southern entrance road. The final channel and culvert design, as well as associated erosion control measures, will be provided in the Final Drainage Report. Preliminary channel design calculations are provided in **Appendix B**.

4.0 MANAGEMENT OF ON-SITE RUNOFF

4.1 On-Site Hydrology

The on-site drainage facilities are designed based on the Rational Method in accordance with the Pinal County Drainage Manual, Volumes I & II [1] [2]. Drainage sub-basins have been delineated based on the lot layout and the preliminary grading plan. The rainfall data is based on NOAA Atlas 14 values with 2.31 inches of precipitation depth for the 100-year, 2-hour storm event. Refer to **Appendix C** for NOAA 14 rainfall data and weighted runoff coefficient calculations, and Plate 1 for drainage sub-basins and retention basin locations.

4.2 On-Site Runoff Management Plan

The on-site drainage concept is to provide proper retention for the 100-year 2-hour storm as required by Pinal County [1] [2]. During final engineering, the streets will be designed to convey on-site runoff toward the various retention basins within the site. The local streets will be designed such that the 10-year flows are contained within the top of curbs and 100-year flows are contained within the right-of-way. Where capacity of the street is exceeded, scupper or storm drain systems will be used to remove excess flow from the street and direct it towards retention basins. Scupper and storm drain sizing will be

provided during final design. Riprap erosion protection will also be provided during final design at all scuppers and storm drain outfalls to mitigate against erosion potential.

All finished floors will be set at a minimum of one foot above the 100-year flood elevation and minimum 14-inches above the outfall water surface elevation.

4.3 Retention

The retention basins shown on Plate 1 are designed to retain the runoff from the 100-year, 2-hour storm event for the drainage sub-basins contributing to them, per Pinal County requirements [1] [2], using the following equation:

$$V_{Req} = C * \frac{P}{12} * A$$

V_{Req} = Required storage volume (acre-ft)

C = Runoff coefficient

P = Rainfall depth per NOAA Atlas 14; 2.31 inches (see **Appendix C**)

A = Area (acres)

A runoff coefficient of 0.82 is used for residential lots (Medium Density Residential), 0.95 for pavement, and 0.50 (Desert Landscaping 2), per Table 2-1 of PCDM Volume II [2]. Retention basins are designed with a maximum water depth of 3 feet with an additional 1 foot of freeboard. Retention will also be provided for the half streets adjacent to the site, which includes N. Green Rd., W. Papago Rd, the Southern Infrastructure Rd. and the Eastern Infrastructure Rd.

Retention basins will be designed in close coordination with the landscape architect to allow for an aesthetically pleasing and hydraulically efficient multi-use facility.

5.0 SUMMARY AND CONCLUSIONS

1. Off-site flows of 155-cfs impact the site from the south. A proposed channel, the South Channel, will collect off-site flows conveying them west along the southern boundary of the site. The South Channel drains into basin R-B14 where flows will overtop to the east, restoring the off-site flow pattern back to historical conditions.
2. Retention basins are designed to retain storm water from the 100-year, 2-hour storm.
4. According to the FIRM panel number 04021C1125E, Map Revised December 4, 2007, the site is located in Zone "X".
5. All-weather access to the site will be provided, per the Pinal County Drainage Ordinance requirements.
6. The design of streets and hydraulic design of the site will be based on, and in accordance with, the *Pinal County Drainage Manuals, Vol. I & II*, the *Pinal County Drainage Ordinance*, as well as the *Pinal County Floodplain Ordinance*, as applicable.
7. Design of the site is not anticipated to cause any adverse drainage impacts or increased drainage problems for adjacent properties, upstream or downstream.

6.0 REFERENCES

- [1] Pinal County, "Pinal County Drainage Manual, Volume I: Design Criteria", August 2004.
- [2] Pinal County, "Pinal County Drainage Manual, Volume II: Design Methodology and Procedures", August 2004.
- [3] Pinal County, "Pinal County Drainage Ordinance No. 100798-DO", October 7, 1998.
- [4] Federal Emergency Management Agency, "National Flood Insurance Program, Flood Insurance Rate Map, Pinal County, Arizona and Incorporated Areas, Panel 1125 of 2575, Map Number 04021C1125E," Effective December 4, 2007.
- [5] Wood, Patel & Associates, Inc., "Vekol Wash Tributary Hydrology Update Report," October 2011.
- [6] KVL Consultants, Inc. and the Flood Control District of Maricopa County, *Flood Control District of Maricopa County Drainage Design Management System for Windows (DDMSW)*.

FIGURES

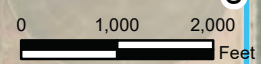
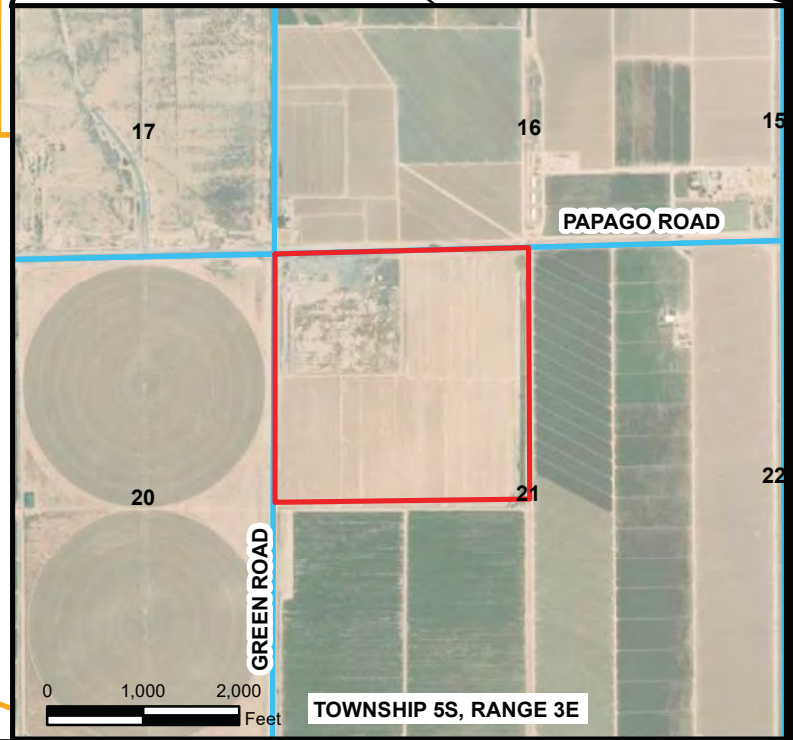
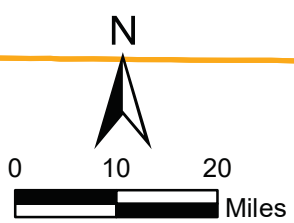
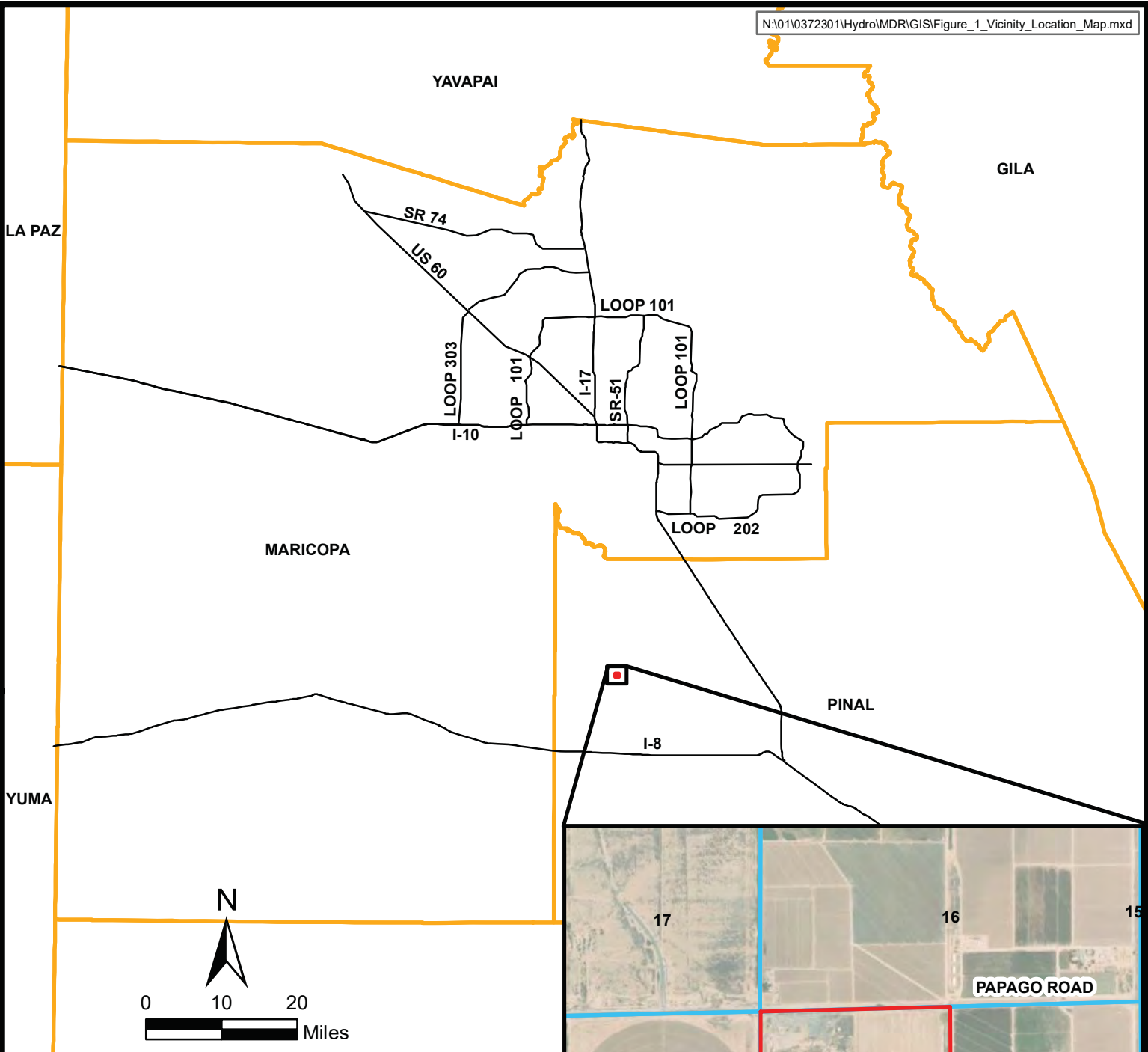

LEGEND:

- Site Boundary
- COUNTY BOUNDARY
- SECTION BOUNDARY
- FREEWAY / MAJOR ROAD
- 05** SECTION ID



4550 NORTH 12TH STREET
 PHOENIX, ARIZONA 85014
 TELEPHONE (602) 264-6831

VENIDA

VICINITY & LOCATION MAP

JOB NO.
 01-0372301

FIGURE 1

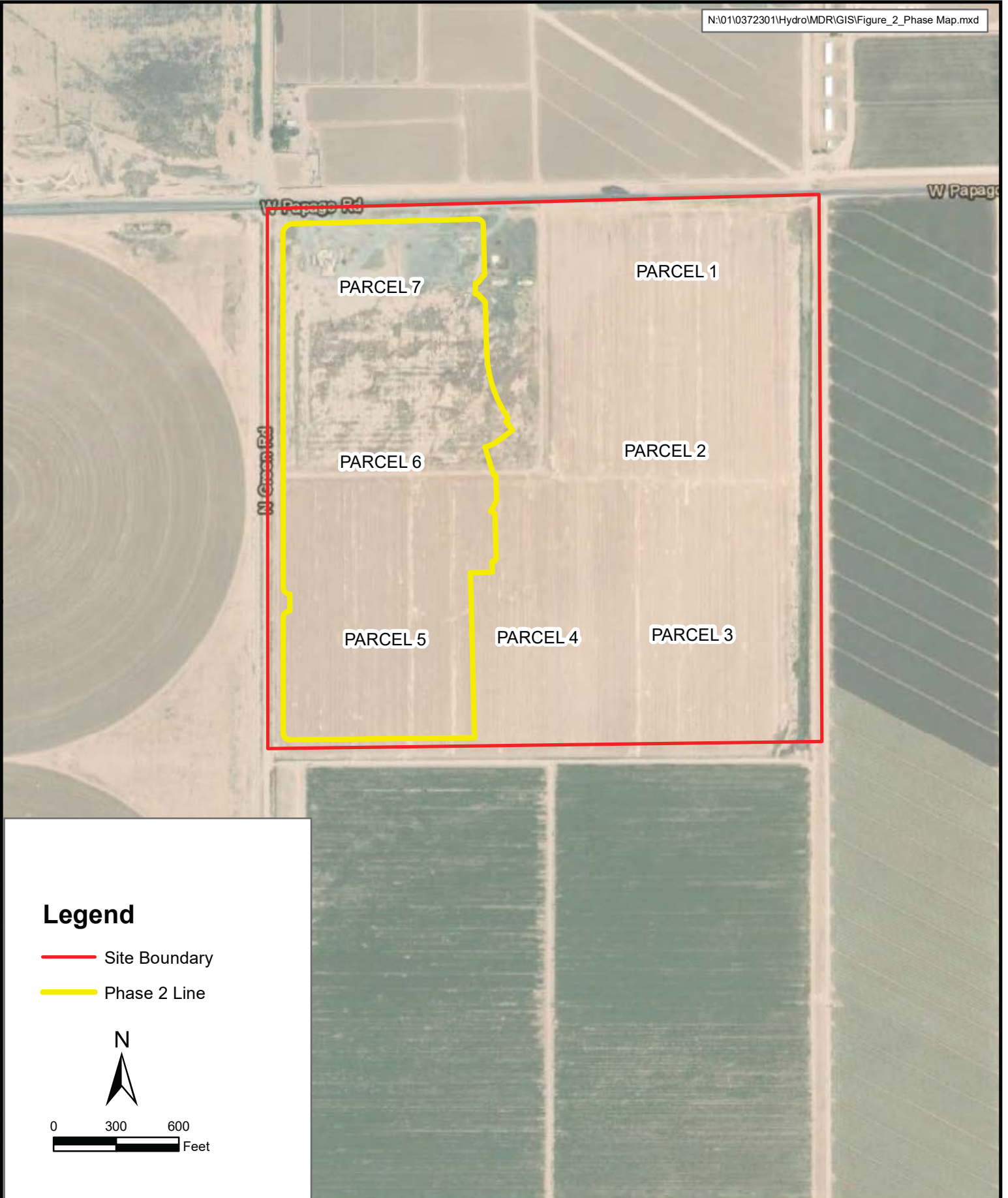

Legend

- Site Boundary
- Phase 2 Line



0 300 600
Feet



4550 NORTH 12TH STREET
PHOENIX, ARIZONA 85014
TELEPHONE (602) 264-6831

VENIDA

JOB NO.
01-0372301

PHASE AND PARCEL MAP

FIGURE 2

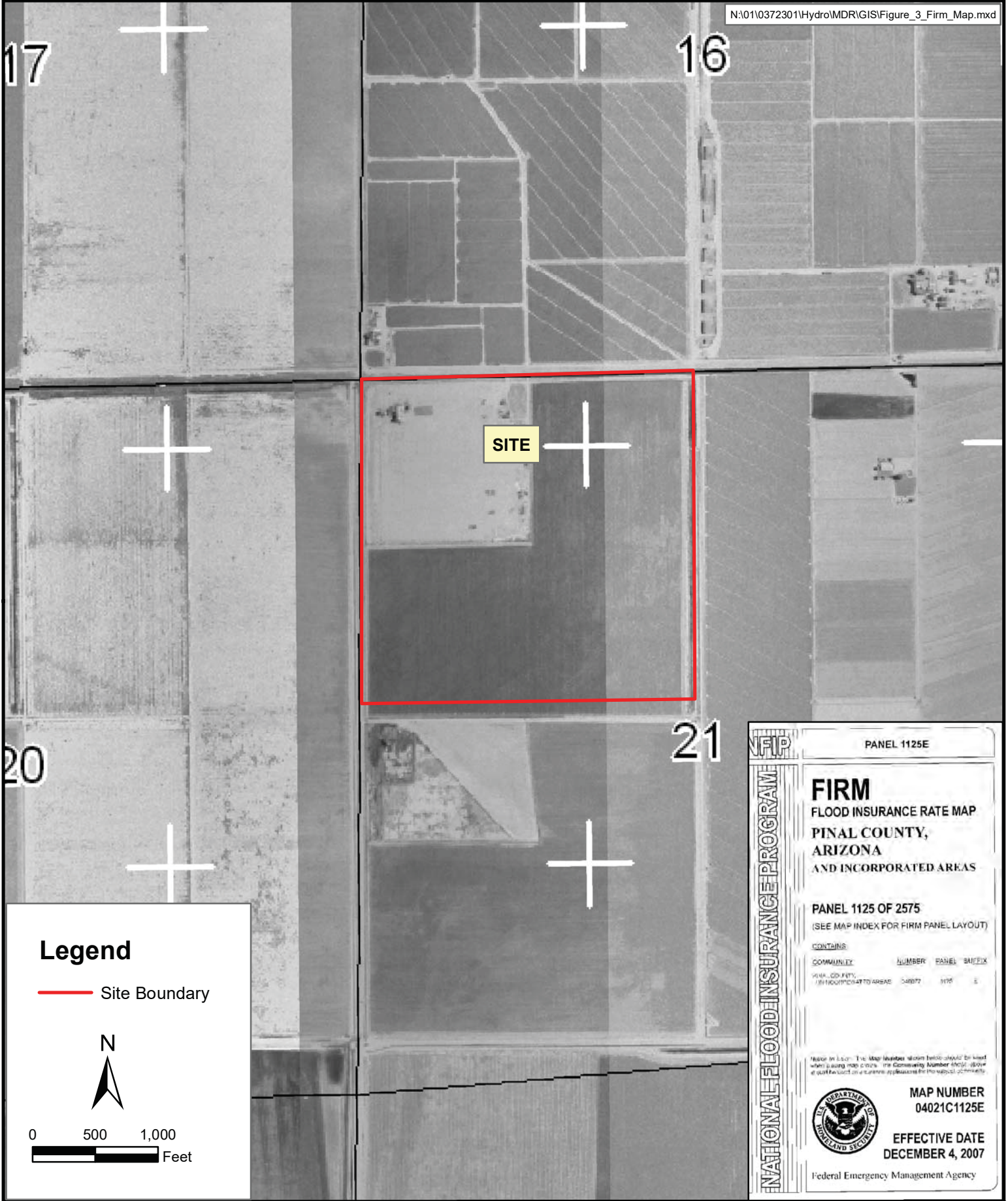

Legend

— Site Boundary



0 500 1,000
Feet

NFP PANEL 1125E

FIRM
FLOOD INSURANCE RATE MAP
PINAL COUNTY,
ARIZONA
AND INCORPORATED AREAS

PANEL 1125 OF 2575
(SEE MAP INDEX FOR FIRM PANEL LAYOUT)

CONTAINS

COMMUNITY	NUMBER	PANEL	SUFFIX
VENA CO. FERTY (BETHQUINQUET) AREAS	040072	1125	E

Map in Use: This map number shown below should be used when a rating map is shown in Community Number (NCE) above it and the fact on a separate application for the subject community.

MAP NUMBER
04021C1125E

EFFECTIVE DATE
DECEMBER 4, 2007

Federal Emergency Management Agency

NATIONAL FLOOD INSURANCE PROGRAM



4550 NORTH 12TH STREET
PHOENIX, ARIZONA 85014
TELEPHONE (602) 264-6831

VENIDA

JOB NO.
01-0372301

FLOOD INSURANCE RATE MAP

FIGURE 3

APPENDICES

APPENDIX A

Off-Site Hydrology: HEC-1 Models and Exhibits

HEC-1 Pre-Project Model:
100-yr, 6-hr

```

1*****
*
* FLOOD HYDROGRAPH PACKAGE (HEC-1)
* JUN 1998
* VERSION 4.1
*
* RUN DATE 09SEP21 TIME 14:58:14
*
*****

```

```

*****
*
* U.S. ARMY CORPS OF ENGINEERS
* HYDROLOGIC ENGINEERING CENTER
* 609 SECOND STREET
* DAVIS, CALIFORNIA 95616
* (916) 756-1104
*
*****

```

```

X X XXXXXXX XXXXX X
X X X X X XX
X X X X X
XXXXXX XXXX X XXXXX X
X X X X X
X X X X X
X X XXXXXXX XXXXX XXX

```

THIS PROGRAM REPLACES ALL PREVIOUS VERSIONS OF HEC-1 KNOWN AS HEC1 (JAN 73), HEC1GS, HEC1DB, AND HEC1KW.

THE DEFINITIONS OF VARIABLES -RTIMP- AND -RTIOR- HAVE CHANGED FROM THOSE USED WITH THE 1973-STYLE INPUT STRUCTURE. THE DEFINITION OF -AMSK- ON RM-CARD WAS CHANGED WITH REVISIONS DATED 28 SEP 81. THIS IS THE FORTRAN77 VERSION
NEW OPTIONS: DAMBREAK OUTFLOW SUBMERGENCE , SINGLE EVENT DAMAGE CALCULATION, DSS:WRITE STAGE FREQUENCY,
DSS:READ TIME SERIES AT DESIRED CALCULATION INTERVAL LOSS RATE:GREEN AND AMPT INFILTRATION
KINEMATIC WAVE: NEW FINITE DIFFERENCE ALGORITHM

```

LINE ID.....1.....2.....3.....4.....5.....6.....7.....8.....9.....10
1 ID Flood Control District of Pinal County
2 ID VENIDA EX 6HR - VENIDA EXISTING CONDITIONS 100-YR 6-HR
3 ID 100 YEAR
4 ID 6 Hour Storm
5 ID Unit Hydrograph: Clark
6 ID Storm: Single
7 ID 09/09/2021
*DIAGRAM
8 IT 10 1JAN99 0 2000
9 IO 5
10 IN 15
*
*
11 KK 1 BASIN
12 BA 0.226
13 PB 2.639
14 PC 0.000 0.008 0.016 0.025 0.033 0.041 0.050 0.058 0.066 0.074
15 PC 0.087 0.099 0.118 0.138 0.216 0.377 0.834 0.911 0.931 0.950
16 PC 0.962 0.972 0.983 0.991 1.000
17 LG 0.50 0.25 4.28 0.63 0
18 UC 1.028 1.038
19 UA 0 3.0 5.0 8.0 12.0 20.0 43.0 75.0 90.0 96.0
20 UA 100
*
21 KK S1 STORAGE
22 KO
23 RS 1 STOR
24 SV 1.49 1.49 1.49
25 SE 1231.7 1231.80 1231.90
26 SS 1231.8 29.00 3.00 1.50
*
27 KK R1 ROUTE
28 RS 1 FLOW
29 RC 0.035 0.035 0.035 2696 0.0040 1231.91
30 RX 0.20 63.20 112.20 162.20 232.50 344.30 394.30 450.00
31 RY 1226.1 1223.71 1223.94 1223.76 1224.09 1223.91 1223.72 1224.00
*
32 KK 2 BASIN
33 BA 0.118
34 LG 0.50 0.25 5.05 0.42 0
35 UC 0.675 0.471
36 UA 0 3.0 5.0 8.0 12.0 20.0 43.0 75.0 90.0 96.0
37 UA 100
*
38 KK C1 COMBINE
39 HC 2
*

```

LINE	ID	1	2	3	4	5	6	7	8	9	10
40	KK	3	BASIN								
41	BA	0.112									
42	LG	0.50	0.25	5.05	0.42	0					
43	UC	0.717	0.552								
44	UA	0	3.0	5.0	8.0	12.0	20.0	43.0	75.0	90.0	96.0
45	UA	100									
	*										
46	KK	C2	COMBINE								
47	HC	2									
	*										
48	ZZ										

1

SCHEMATIC DIAGRAM OF STREAM NETWORK

INPUT LINE (V) ROUTING (---) DIVERSION OR PUMP FLOW

NO. (.) CONNECTOR (<---) RETURN OF DIVERTED OR PUMPED FLOW

```

11      1
      V
      V
21      S1
      V
      V
27      R1
      .
      .
32      .      2
      .      .
      .      .
38      C1.....
      .
      .
40      .      3
      .      .
      .      .
46      C2.....

```

(***) RUNOFF ALSO COMPUTED AT THIS LOCATION

```

*****
*
* FLOOD HYDROGRAPH PACKAGE (HEC-1) *
* JUN 1998 *
* VERSION 4.1 *
*
* RUN DATE 09SEP21 TIME 14:58:14 *
*
*****

```

```

*****
*
* U.S. ARMY CORPS OF ENGINEERS *
* HYDROLOGIC ENGINEERING CENTER *
* 609 SECOND STREET *
* DAVIS, CALIFORNIA 95616 *
* (916) 756-1104 *
*
*****

```

Flood Control District of Pinal County
 VENIDA EX 6HR - VENIDA EXISTING CONDITIONS 100-YR 6-HR
 100 YEAR
 6 Hour Storm
 Unit Hydrograph: Clark
 Storm: Single
 09/09/2021

9 IO OUTPUT CONTROL VARIABLES

IPRNT	5	PRINT CONTROL
IPLOT	0	PLOT CONTROL
QSCAL	0.	HYDROGRAPH PLOT SCALE

IT HYDROGRAPH TIME DATA

NMIN	10	MINUTES IN COMPUTATION INTERVAL
IDATE	1JAN99	STARTING DATE
ITIME	0000	STARTING TIME
NQ	2000	NUMBER OF HYDROGRAPH ORDINATES
NDDATE	14JAN99	ENDING DATE
NDTIME	2110	ENDING TIME
ICENT	19	CENTURY MARK

COMPUTATION INTERVAL 0.17 HOURS
 TOTAL TIME BASE 333.17 HOURS

ENGLISH UNITS

DRAINAGE AREA	SQUARE MILES
PRECIPITATION DEPTH	INCHES
LENGTH, ELEVATION	FEET
FLOW	CUBIC FEET PER SECOND
STORAGE VOLUME	ACRE-FEET
SURFACE AREA	ACRES
TEMPERATURE	DEGREES FAHRENHEIT

*** ** ** ** **

* *
21 KK * S1 * STORAGE
* *

22 KO OUTPUT CONTROL VARIABLES
IPRNT 5 PRINT CONTROL
IPLOT 0 PLOT CONTROL
QSCAL 0. HYDROGRAPH PLOT SCALE

1

RUNOFF SUMMARY
FLOW IN CUBIC FEET PER SECOND
TIME IN HOURS, AREA IN SQUARE MILES

+	OPERATION	STATION	PEAK FLOW	TIME OF PEAK	AVERAGE FLOW FOR MAXIMUM PERIOD			BASIN AREA	MAXIMUM STAGE	TIME OF MAX STAGE
					6-HOUR	24-HOUR	72-HOUR			
+	HYDROGRAPH AT	1	75.	4.83	19.	5.	2.	0.23		
+	ROUTED TO	S1	75.	4.83	15.	4.	1.	0.23	1234.36	5.33
+	ROUTED TO	R1	35.	5.67	15.	4.	1.	0.23	1223.86	5.67
+	HYDROGRAPH AT	2	84.	4.50	11.	3.	1.	0.12		
+	2 COMBINED AT	C1	84.	4.50	26.	7.	2.	0.34		
+	HYDROGRAPH AT	3	71.	4.50	11.	3.	1.	0.11		
+	2 COMBINED AT	C2	155.	4.50	37.	9.	3.	0.46		

*** NORMAL END OF HEC-1 ***

HEC-1 Pre-Project Model:
100-yr, 24-hr

*

HEC-1 INPUT

LINE	ID	1	2	3	4	5	6	7	8	9	10
45	KK	C1 COMBINE									
46	HC	2									
	*										
47	KK	3 BASIN									
48	BA	0.112									
49	LG	0.50	0.25	5.05	0.42	0					
50	UC	0.692	0.531								
51	UA	0	3.0	5.0	8.0	12.0	20.0	43.0	75.0	90.0	96.0
52	UA	100									
	*										
53	KK	C2 COMBINE									
54	HC	2									
	*										
55	ZZ										

1

SCHEMATIC DIAGRAM OF STREAM NETWORK

INPUT LINE	(V) ROUTING	(--->) DIVERSION OR PUMP FLOW
NO.	(.) CONNECTOR	(<---) RETURN OF DIVERTED OR PUMPED FLOW
11	1	
	V	
	V	
28	S1	
	V	
	V	
34	R1	
	.	
39	.	2
	.	.
	.	.
45	C1.....	
	.	
	.	
47	.	3
	.	.
	.	.
53	C2.....	

(***) RUNOFF ALSO COMPUTED AT THIS LOCATION

```

1*****
*
* FLOOD HYDROGRAPH PACKAGE (HEC-1) *
* JUN 1998 *
* VERSION 4.1 *
* RUN DATE 14SEP21 TIME 09:38:42 *
*
*****

```

```

*****
*
* U.S. ARMY CORPS OF ENGINEERS *
* HYDROLOGIC ENGINEERING CENTER *
* 609 SECOND STREET *
* DAVIS, CALIFORNIA 95616 *
* (916) 756-1104 *
*
*****

```

Flood Control District of Pinal County
 VENIDA EX 24HR - VENIDA EXISTING CONDITIONS 100-YR 6-HR
 100 YEAR
 24 Hour Storm
 Unit Hydrograph: Clark
 Storm: Single
 09/14/2021

9 IO OUTPUT CONTROL VARIABLES
 IPRNT 5 PRINT CONTROL
 IPLOT 0 PLOT CONTROL
 QSCAL 0. HYDROGRAPH PLOT SCALE

IT HYDROGRAPH TIME DATA
 NMIN 10 MINUTES IN COMPUTATION INTERVAL
 IDATE 1JAN99 STARTING DATE
 ITIME 0000 STARTING TIME
 NQ 2000 NUMBER OF HYDROGRAPH ORDINATES
 NDDATE 14JAN99 ENDING DATE
 NDTIME 2110 ENDING TIME
 ICENT 19 CENTURY MARK

COMPUTATION INTERVAL 0.17 HOURS
 TOTAL TIME BASE 333.17 HOURS

ENGLISH UNITS
 DRAINAGE AREA SQUARE MILES
 PRECIPITATION DEPTH INCHES

LENGTH, ELEVATION FEET
 FLOW CUBIC FEET PER SECOND
 STORAGE VOLUME ACRE- FEET
 SURFACE AREA ACRES
 TEMPERATURE DEGREES FAHRENHEIT

*** **

 * *
 28 KK * S1 * STORAGE
 * *

29 KO OUTPUT CONTROL VARIABLES
 IPRNT 5 PRINT CONTROL
 IPLOT 0 PLOT CONTROL
 QSCAL 0. HYDROGRAPH PLOT SCALE



1

RUNOFF SUMMARY
 FLOW IN CUBIC FEET PER SECOND
 TIME IN HOURS, AREA IN SQUARE MILES

+	OPERATION	STATION	PEAK FLOW	TIME OF PEAK	AVERAGE FLOW FOR MAXIMUM PERIOD			BASIN AREA	MAXIMUM STAGE	TIME OF MAX STAGE
					6-HOUR	24-HOUR	72-HOUR			
+	HYDROGRAPH AT	1	66.	12.83	16.	4.	1.	0.23		
+	ROUTED TO	S1	66.	12.83	12.	3.	1.	0.23	1234.94	12.83
+	ROUTED TO	R1	32.	13.67	12.	3.	1.	0.23	1223.85	13.67
+	HYDROGRAPH AT	2	75.	12.50	10.	3.	1.	0.12		
+	2 COMBINED AT	C1	75.	12.50	22.	6.	2.	0.34		
+	HYDROGRAPH AT	3	65.	12.50	10.	2.	1.	0.11		
+	2 COMBINED AT	C2	140.	12.50	32.	8.	3.	0.46		

*** NORMAL END OF HEC-1 ***

Legend

-  Site Boundary
-  HEC-1 Subbasin
-  Existing Contours

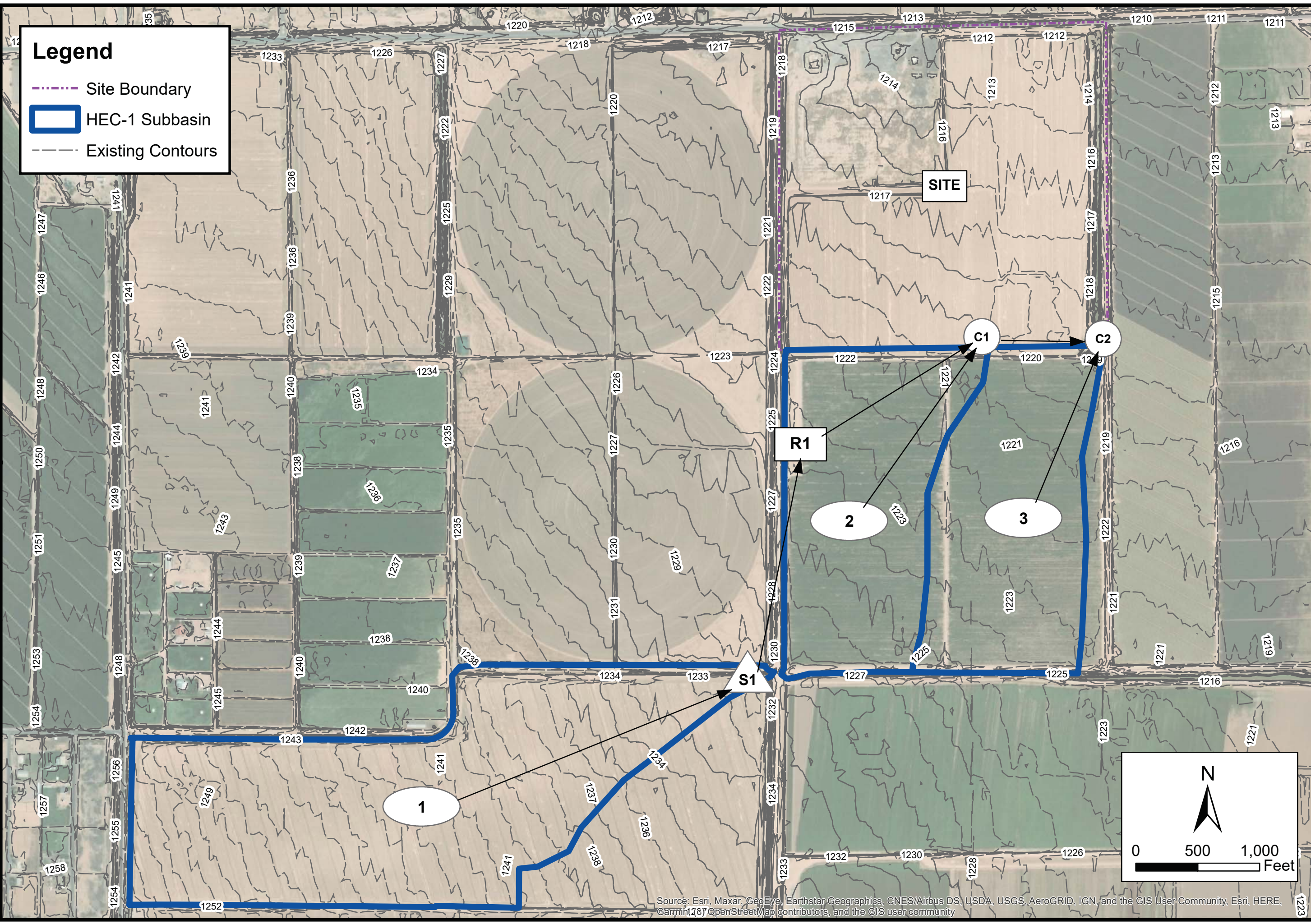

Source: Esri, Maxar, GeoEye, Earthstar Geographics, CNES/Airbus DS, USDA, USGS, AeroGRID, IGN, and the GIS User Community, Esri, HERE, Garmin, OpenStreetMap contributors, and the GIS user community

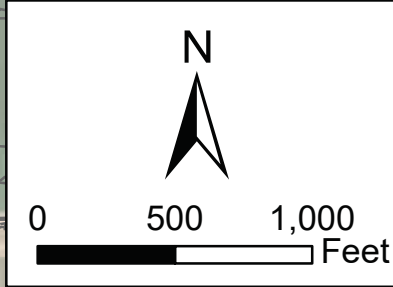

PRE-PROJECT HEC-1 SCHEMATIC MAP

VENIDA

4550 NORTH 12TH STREET
PHOENIX, ARIZONA 85014
TELEPHONE (602) 264-6831



JOB NO.
01-0372301

EXHIBIT 1